



**Shenzhen Hi-Link Electronic Co.,Ltd**

---

# **HLK-LD2410C**

**Human presence sensing module  
serial communication protocol**

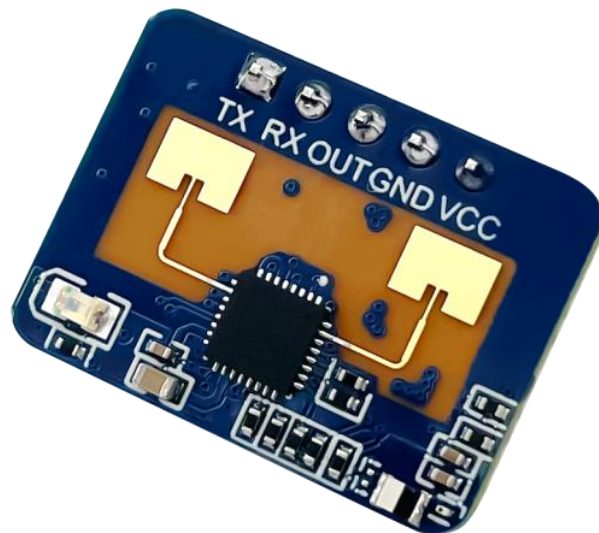

Version: V1.00    Modify date: 2022-11-7

Copyright @Shenzhen Hi-Link Electronic Co.,Ltd

# Catalog

- 1 Communication interface introduction .....5**
  - 1.1 Pin definition .....5**
  - 1.2 Use and configuration ..... 6**
    - 1.2.1 Typical application circuits ..... 6**
    - 1.2.2 The role of configuration parameters ..... 6**
    - 1.2.3 Visual configuration tool description ..... 7**
- 2 Communication protocols ..... 8**
  - 2.1 Protocol format .....8**
    - 2.1.1 Protocol data format ..... 8**
    - 2.1.2 Command protocol frame format ..... 8**
  - 2.2 Send command with ACK ..... 9**
    - 2.2.1 Enabling configuration commands .....9**
    - 2.2.2 End configuration command .....9**
    - 2.2.3 Maximum distance gate and unoccupied duration parameters  
configuration command ..... 10**
    - 2.2.4 Read parameter command ..... 11**
    - 2.2.5 Enabling engineering mode command ..... 11**
    - 2.2.6 Close project mode command ..... 12**
    - 2.2.7 Distance gate sensitivity configuration command ..... 12**
    - 2.2.8 Read firmware version command ..... 13**
    - 2.2.9 Set serial port baud rate ..... 13**
    - 2.2.10 Restore factory settings ..... 14**
    - 2.2.11 Restart module ..... 15**
    - 2.2.12 Bluetooth settings ..... 16**
    - 2.2.13 Get mac address ..... 16**
    - 2.2.14 Obtaining bluetooth permissions ..... 16**
    - 2.2.15 Setting Bluetooth password ..... 17**

---

2.2.16 Distance resolution setting .....	17
2.2.17 Query distance resolution setting .....	18
2.3 Radar data output protocol .....	18
2.3.1 Reported data frame format .....	19
2.3.2 Target data composition .....	19
2.4 Radar command configuration method .....	20
2.4.1 Radar command configuration steps .....	20
3 Revision records .....	22
4 Technical support and contact information .....	23

# Chart Index

<b>Table 1</b>	<b>Pin definition table</b> .....	<b>5</b>
<b>Table 2</b>	<b>Send command protocol frame format</b> .....	<b>9</b>
<b>Table 3</b>	<b>Data format in the sending frame</b> .....	<b>9</b>
<b>Table 4</b>	<b>ACK command protocol frame format</b> .....	<b>9</b>
<b>Table 5</b>	<b>ACK intra-frame data format</b> .....	<b>9</b>
<b>Table 6</b>	<b>Serial port baud rate selection</b> .....	<b>14</b>
<b>Table 7</b>	<b>Factory default configuration values</b> .....	<b>15</b>
<b>Table 8</b>	<b>Distance resolution selection</b> .....	<b>18</b>
<b>Table 9</b>	<b>Reported data frame format</b> .....	<b>19</b>
<b>Table 10</b>	<b>Intra-frame data frame format</b> .....	<b>19</b>
<b>Table 11</b>	<b>Data type description</b> .....	<b>19</b>
<b>Table 12</b>	<b>Target basic information data composition</b> .....	<b>19</b>
<b>Table 13</b>	<b>Target state value description</b> .....	<b>20</b>
<b>Table 14</b>	<b>Engineering model target data composition</b> .....	<b>20</b>
<b>Figure 1</b>	<b>Module pin definition diagram</b> .....	<b>5</b>
<b>Figure 2</b>	<b>Radar command configuration process</b> .....	<b>21</b>

# 1 Communication interface introduction

## 1.1 Pin definition

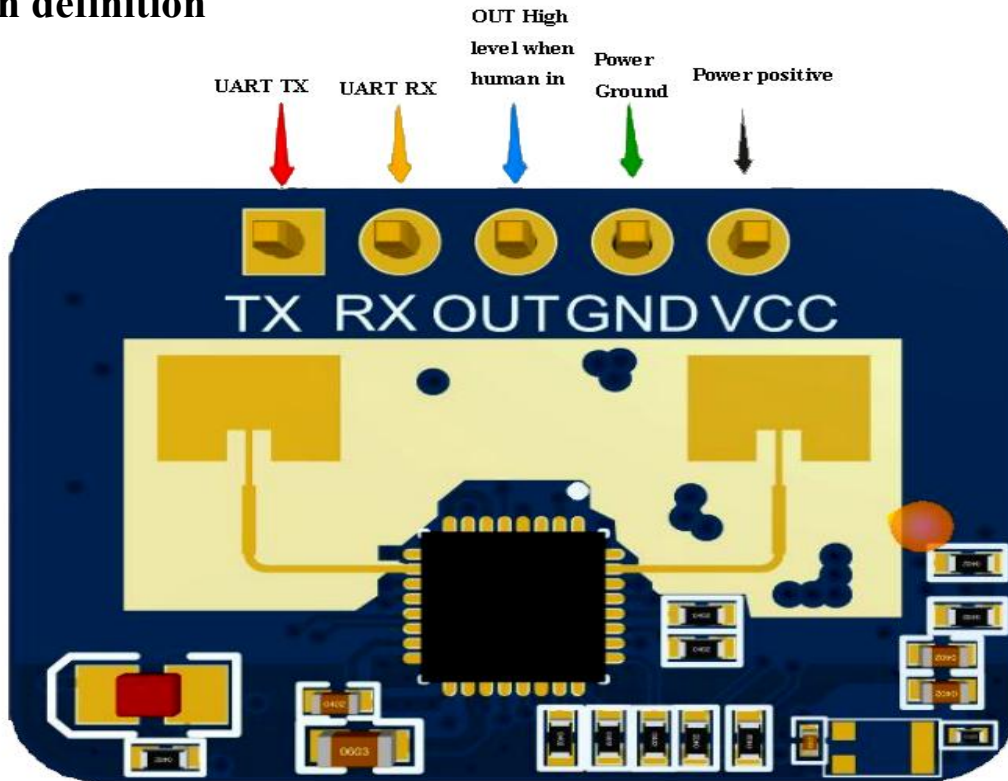

Figure 1 Module pin definition diagram

Pin	Symbol	Name	Function
1	UART_Tx	UART Tx	UART Tx pin
2	UART_Rx	UART Rx	UART Rx pin
3	OUT	Target state output	Human presence detected: output high level No human presence: output low level
4	GND	Power Ground	Power Ground
5	VCC	Power input	Power input 5~12V (Suggest: 5V)

Table 1 Pin definition table

## 1.2 Use and configuration

### 1.2.1 Typical application circuits

LD2410C module directly through an IO pin output the detected target state (someone high, no one low), but also through the serial port in accordance with the prescribed protocol for the output of the detection results data, the serial output data contains the target state and distance auxiliary information, etc., the user can be used flexibly according to specific application scenarios.

The module power supply voltage is 5V and the power supply capacity of the input power supply is required to be greater than 200mA.

The module IO output level is 3.3 V. The default baud rate of the serial port is 256000, with 1 stop bit and no parity bit.

### 1.2.2 The role of configuration parameters

Users can modify the configuration parameters to the module through the serial port of LD2410C to adapt to different application requirements.

The configurable radar detection parameters include the following :

- **The farthest detection distance**

Set the maximum detectable distance, only human targets that appear within this maximum distance will be detected and the result will be output.

Set up in units of distance from the door, each distance from the door is 0.75m.

Including motion detection of the farthest distance gate and stationary detection of the farthest distance gate, can be set in the range of 1 to 8, for example, set the farthest distance gate for 2, only the presence of the human body within 1.5m will be effectively detected and output the results.

- **Sensitivity**

The presence of a target is determined when the detected target energy value (range 0 to 100) is greater than the sensitivity value, otherwise it is ignored.

Sensitivity value can be set in the range of 0 to 100. Each distance gate can be set independently of the sensitivity, that is, the detection of different distances within the

range of precise adjustment, local precision detection or filtering of specific areas of interference sources.

In addition if the sensitivity of a distance gate is set to 100, the effect of not identifying the target under this distance gate can be achieved. For example, the sensitivity of distance gate 3 and distance gate 4 is set to 20, and the sensitivity of all other distance gates is set to 100, then only the human body within 2.25 to 3.75m of the distance module can be achieved to detect.

### ● **no-one duration**

Radar in the output from occupied to unoccupied results, will continue to report a period of time on the occupied, if the radar test range in this time period continued unoccupied, the radar reported unoccupied; if the radar detects someone in this time period, then refreshed this time, unit seconds. Equivalent to no one delay time, after the person left, keep no one more than this duration before the output status for no one.

### **1.2.3 Visual configuration tool description**

In order to facilitate users to quickly and efficiently test and configure the module, the PC terminal configuration tool is provided. Users can use this tool software to connect to the serial port of the module, read and configure the parameters of the module, and also receive the detection result data reported by the module, and make real-time visualization display, which is greatly convenient for users.

#### **Usage of the Uplink tool:**

1. properly connect the module serial port with the USB to serial port tool.
2. select the corresponding serial port number in the upper computer tool, set the baud rate 256000, select the engineering mode and click connect the device.
3. after successful connection, click the start button, the right graphical interface will display the detection results and data.
4. after connection, when the start button is not clicked, or click stop after starting, the mode parameter information can be read or set.

Note: Parameters cannot be read and configured after clicking Start, and can only be configured after stopping.

The interface and common functions of the OP tool are shown below :

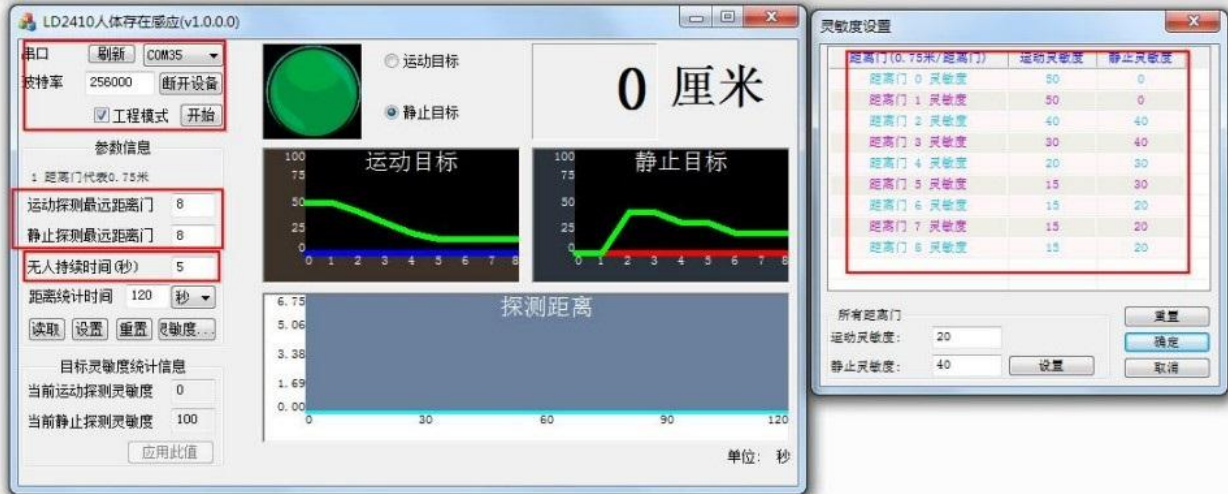

The ball is the target status output indication: **red** means there is a moving target; **purple** means there is a stationary target; **green** means no one.

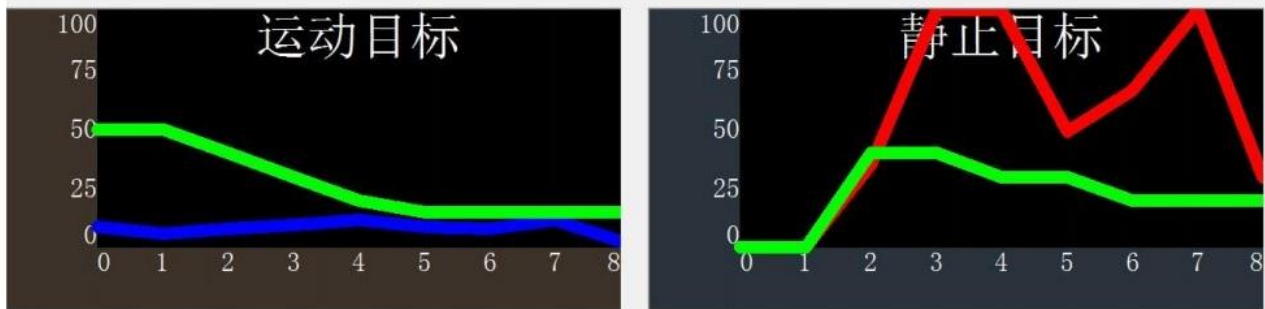

Green line: the set sensitivity

Blue line: moving target energy value on each distance gate

Red line: static target energy value on each range gate

## 2 Communication protocols

The LD2410C communicates with the outside world through a serial port (TTL level). Data output and parameter configuration commands of the radar are carried out under this protocol. The default baud rate of the radar serial port is 256000, 1 stop bit, no parity bit.

### 2.1 Protocol format

#### 2.1.1 Protocol data format

The LD2410C uses small-end format for serial data communication, and all data in the following tables are in hexadecimal.

#### 2.1.2 Command protocol frame format



The format of the protocol-defined radar configuration commands and ACK commands are shown in Table 1 to Table 4.

**Table 2 Send command protocol frame format**

Frame header	Intra-frame data length	Intra-frame data	End of frame
FD FC FB FA	2 bytes	See Table 3	04 03 02 01

**Table 3 Data format in the sending frame**

Command word (2 bytes)	Command value (N bytes)
------------------------	-------------------------

**Table 4 ACK command protocol frame format**

Frame header	Intra-frame data length	Intra-frame data	End of frame
FD FC FB FA	2 bytes	See Table 5	04 03 02 01

**Table 5 ACK intra-frame data format**

Send command word   0x0100 (2 bytes)	Return value (N bytes)
--------------------------------------	------------------------

## 2.2 Send command with ACK

### 2.2.1 Enabling configuration commands

Any other commands issued to the radar must be executed after this command is issued, otherwise they are invalid.

Command word: 0x00FF

Command value: 0x0001

Return value: 2 bytes ACK status (0 success, 1 failure) + 2 bytes protocol version (0x0001) + 2 bytes buffer size (0x0040)

Send data:

<b>FD FC FB FA</b>	<b>04 00</b>	<b>FF 00</b>	<b>01 00</b>	<b>04 03 02 01</b>
--------------------	--------------	--------------	--------------	--------------------

Radar ACK (success):

<b>FD FC FB FA</b>	<b>08 00</b>	<b>FF 01</b>	<b>00 00</b>	<b>01 00</b>	<b>40 00</b>	<b>04 03 02 01</b>
--------------------	--------------	--------------	--------------	--------------	--------------	--------------------

### 2.2.2 End configuration command

End the configuration command and the radar resumes working mode after execution. If you need to issue other commands again, you need to send the enable configuration command first.

Command word: 0x00FE

Command value: None

Return value: 2-byte ACK status (0 success, 1 failure)

Send data:

FD FC FB FA	02 00	FE 00	04 03 02 01
-------------	-------	-------	-------------

Radar ACK (success):

FD FC FB FA	04 00	FE 01	00 00	04 03 02 01
-------------	-------	-------	-------	-------------

### 2.2.3 Maximum distance gate and unoccupied duration parameters configuration command

This command sets the radar maximum detection distance gate (motion & stationary) (configuration range 2~8), and the unmanned duration parameter (configuration range 0~65535 seconds). Please refer to the specific parameter word Table 5- 5. This configuration value is not lost when power is dropped.

Command word: 0x0060

Command value: 2-byte maximum motion distance gate word + 4-byte maximum motion distance gate parameter + 2-byte maximum standstill distance gate word + 4-byte maximum standstill distance gate parameter + 2-byte unoccupied duration word + 4-byte unoccupied duration parameter

Return value: 2-byte ACK status (0 success, 1 failure)

0x0060 protocol parameter word

Parameter name	Parameter word
Maximum movement distance door	0x0000
Maximum resting distance door	0x0001
No one duration	0x0002

Send data: maximum distance door 8 (motion & stationary), no one duration 5 seconds

FD FC FB FA	14 00	60 00	00 00	08 00 00 00	01 00	08 00 00 00	02 00	05 00 00 00	04 03 02 01
-------------	-------	-------	-------	-------------	-------	-------------	-------	-------------	-------------

Radar ACK (success):

FD FC FB FA	04 00	60 01	00 00	04 03 02 01
-------------	-------	-------	-------	-------------

## 2.2.4 Read parameter command

This command allows you to read the current configuration parameters of the radar.

Command word: 0x0061

Command value: None

Return value: 2 bytes ACK status (0 success, 1 failure) + header (0xAA) + max distance gate N (0x08) + configure max motion distance gate + configure max rest distance gate + distance gate 0 motion sensitivity (1 byte) + ... + distance gate N motion sensitivity (1 byte) + distance gate 0 rest sensitivity 1 byte) + ... + distance gate N stationary sensitivity (1 byte) + unoccupied duration (2 bytes)

Send data:

FD FC FB FA	02 00	61 00	04 03 02 01
-------------	-------	-------	-------------

Radar ACK: (success, maximum distance gate 8, configured motion distance gate 8, stationary distance gate 8, 0~8 motion sensitivity 20, 0~8 stationary sensitivity 25, unoccupied duration 5 seconds)

Byte 1~4		Byte 5, 6		Byte 7, 8		Byte 9, 10	Byte 11	Byte 12	Byte 13	Byte 14	Byte 15	Byte 16	Byte 17	Byte 18
FD FC FB FA		1C 00		61 01		00 00	AA	08	08	08	14	14	14	14
Byte 19	Byte 20	Byte 21		Byte 22	Byte 23	Byte 24	Byte 25	Byte 26	Byte 27	Byte 28	Byte 29	Byte 30		
14	14	14		14	14	19	19	19	19	19	19	19		
Byte 31	Byte 32	Byte 33, 34		Byte 35~38										
19	19	05 00		04 03 02 01										

## 2.2.5 Enabling engineering mode command

This command opens the radar engineering mode. When the engineering mode is turned on, each distance gate energy value will be added to the radar report data, please refer to [2.3.2 Target Data Composition](#) for detailed format. Engineering mode is off by default after the module is powered on, this configuration value is lost when power is lost.

Command word: 0x0062

Command value: None

Return value: 2-byte ACK status (0 success, 1 failure)

Send data:

FD FC FB FA	02 00	62 00	04 03 02 01
-------------	-------	-------	-------------

Radar ACK (success):

FD FC FB FA	04 00	62 01	00 00	04 03 02 01
-------------	-------	-------	-------	-------------

## 2.2.6 Close project mode command

This command turns off the radar engineering mode. After it is turned off, please refer to [2.3.2 Target Data Composition](#) for the format of radar report data.

Command word: 0x0063

Command value: None

Return value: 2-byte ACK status (0 success, 1 failure)

Send data:

FD FC FB FA	02 00	63 00	04 03 02 01
-------------	-------	-------	-------------

Radar ACK (success):

FD FC FB FA	04 00	63 01	00 00	04 03 02 01
-------------	-------	-------	-------	-------------

## 2.2.7 Distance gate sensitivity configuration command

This command configures the sensitivity of the distance gate, and the configured value is not lost when power is dropped. It supports both configuring each distance gate individually and configuring all distance gates to a uniform value at the same time. If setting all distance gates sensitivity to the same value at the same time, the distance gate value needs to be set to 0xFFFF.

Command word: 0x0064

Command value: 2-byte distance gate word + 4-byte distance gate value + 2-byte motion sensitivity word + 4-byte motion sensitivity value + 2-byte standstill sensitivity word + 4-byte standstill sensitivity value

Return value: 2-byte ACK status (0 success, 1 failure)

0x0064 protocol parameter word

Parameter name	Parameter word
Distance door	0x0000

Movement sensitivity word	0x0001
Static Sensitivity Word	0x0002

Send data: configured distance from the door 3 motion sensitivity 40, stationary sensitivity 40

FD FC FB FA	14 00	64 00	00 00	03 00 00 00	01 00	28 00 00 00	02 00	28 00 00 00	04 03 02 01
-------------	-------	-------	-------	-------------	-------	-------------	-------	-------------	-------------

Radar ACK (success):

FD FC FB FA	04 00	64 01	00 00	04 03 02 01
-------------	-------	-------	-------	-------------

Send data: Configure motion sensitivity 40 for all distance doors, rest sensitivity 40

FD FC FB FA	14 00	64 00	00 00	FF FF 00 00	01 00	28 00 00 00	02 00	28 00 00 00	04 03 02 01
-------------	-------	-------	-------	-------------	-------	-------------	-------	-------------	-------------

Radar ACK (success):

FD FC FB FA	04 00	64 01	00 00	04 03 02 01
-------------	-------	-------	-------	-------------

## 2.2.8 Read firmware version command

This command reads the radar firmware version information.

Command word: 0x00A0

Command value: None

Return value: 2 bytes ACK status (0 success, 1 failure) + 2 bytes firmware type (0x0001) + 2 bytes major version number + 4 bytes minor version number

Send data:

FD FC FB FA	02 00	A0 00	04 03 02 01
-------------	-------	-------	-------------

Radar ACK (success):

FD FC FB FA	0C 00	00 00	00 01	07 01	16 15 09 22	04 03 02 01
-------------	-------	-------	-------	-------	-------------	-------------

The corresponding version number is V1.07.22091615

## 2.2.9 Set serial port baud rate

This command is used to set the baud rate of the serial port of the module. The configured value is not lost when power is lost, and the configured value takes effect after restarting the module.

Command word: 0x00A1

Command value: 2-byte baud rate selection index

Return value: 2-byte ACK status (0 success, 1 failure)

**Table 6 Serial port baud rate selection**

Baud rate selection index value	Baud rate
0x0001	9600
0x0002	19200
0x0003	38400
0x0004	57600
0x0005	115200
0x0006	230400
0x0007	256000
0x0008	460800

The factory default value is 0x0007, which is 256000

Send data:

<b>FD FC FB FA</b>	<b>04 00</b>	<b>A1 00</b>	<b>07 00</b>	<b>04 03 02 01</b>
--------------------	--------------	--------------	--------------	--------------------

Radars ACK (success):

<b>FD FC FB FA</b>	<b>04 00</b>	<b>A1 01</b>	<b>00 00</b>	<b>04 03 02 01</b>
--------------------	--------------	--------------	--------------	--------------------

### 2.2.10 Restore factory settings

This command is used to restore all the configuration values to their non-factory values, which take effect after rebooting the module.

Command word: 0x00A2

Command value: None

Return value: 2-byte ACK status (0 success, 1 failure)

Send data:

<b>FD FC FB FA</b>	<b>02 00</b>	<b>A2 00</b>	<b>04 03 02 01</b>
--------------------	--------------	--------------	--------------------

Radars ACK (success):

<b>FD FC FB FA</b>	<b>04 00</b>	<b>A2 01</b>	<b>00 00</b>	<b>04 03 02 01</b>
--------------------	--------------	--------------	--------------	--------------------

The factory default configuration values are as follows:

**Table 7 Factory default configuration values**

Configuration items	Default value
Maximum movement distance door	8
Maximum resting distance door	8
No one duration	5
Serial port baud rate	256000

Configuration items	Default value	Configuration items	Default value
Motion sensitivity of distance gate 0	50	Static sensitivity of distance gate 0	-(not settable)
Motion sensitivity of distance gate 1	50	Static sensitivity of distance gate 1	-(not settable)
Motion sensitivity of distance gate 2	40	Static sensitivity of distance gate 2	40
Motion sensitivity of distance gate 3	30	Static sensitivity of distance gate 3	40
Motion sensitivity of distance gate 4	20	Static sensitivity of distance gate 4	30
Motion sensitivity of distance gate 5	15	Static sensitivity of distance gate 5	30
Motion sensitivity of distance gate 6	15	Static sensitivity of distance gate 6	20
Motion sensitivity of distance gate 7	15	Static sensitivity of distance gate 7	20
Motion sensitivity of distance gate 8	15	Static sensitivity of distance gate 8	20

### 2.2.11 Restart module

The module receives this command and will automatically restart after the answer is sent.

Command word: 0x00A3

Command value: None

Return value: 2-byte ACK status (0 success, 1 failure)

Send data:

<b>FD FC FB FA</b>	<b>02 00</b>	<b>A3 00</b>	<b>04 03 02 01</b>
--------------------	--------------	--------------	--------------------

Radar ACK (success):

<b>FD FC FB FA</b>	<b>04 00</b>	<b>A3 01</b>	<b>00 00</b>	<b>04 03 02 01</b>
--------------------	--------------	--------------	--------------	--------------------

### 2.2.12 Bluetooth settings

This command is used to control the Bluetooth on or off, the Bluetooth function of the module is on by default.

After receiving this command, a reboot is required for the function to take effect.

Command word: 0x00A4

Command value: 0x0100 Turn on bluetooth 0x0000 Turn off bluetooth

Return value: 2-byte ACK status (0 success, 1 failure)

Send data: (Turn on bluetooth)

FD FC FB FA	04 00	A4 00	01 00	04 03 02 01
-------------	-------	-------	-------	-------------

Radar ACK (success):

FD FC FB FA	04 00	A4 01	00 00	04 03 02 01
-------------	-------	-------	-------	-------------

### 2.2.13 Get mac address

This command is used to query the MAC address.

Command word: 0x00A5

Command value: 0x0001

Return value: 2-byte ACK status (0 success, 1 failure) + 1 byte fixed type (0x00) + 3 bytes MAC address (address is in big terminal order)

Send data:

FD FC FB FA	04 00	A5 00	01 00	04 03 02 01
-------------	-------	-------	-------	-------------

Radar ACK (success):

FD FC FB FA	0A 00	A5 01	00 00	8F 27	2E B8	0F 65	04 03 02 01
-------------	-------	-------	-------	-------	-------	-------	-------------

The mac address queried is: 8F 27 2E B8 0F 65

### 2.2.14 Obtaining bluetooth permissions

This command is used to get the Bluetooth permission, and you can use the APP to get the device information and debugging parameters through Bluetooth after successful acquisition.

Command word: 0x00A8

Command value: 6 bytes of password value (every 2 bytes in small end order)



Return value: 2-byte ACK status (0 success, 1 failure)

The default password is "HiLink", then the corresponding value is 0x4869 (Hi) 0x4c69 (Li) 0x6e6b (nk).

Send data:

FD FC FB FA	08 00	A8 00	48 69	4c 69	6e 6b	48 69	04 03 02 01
-------------	-------	-------	-------	-------	-------	-------	-------------

Radar ACK (success):

FD FC FB FA	04 00	A8 01	00 00	04 03 02 01
-------------	-------	-------	-------	-------------

Note: This response only answers to Bluetooth, not to the serial port.

### 2.2.15 Setting Bluetooth password

This command is used to set the password for Bluetooth control.

Command word: 0x00A9

Command value: 6 bytes of password value (each byte is in small end order)

Return value: 2-byte ACK status (0 success, 1 failure)

Send data:

FD FC FB FA	08 00	A9 00	48 69	4c 69	6e 6b	48 69	04 03 02 01
-------------	-------	-------	-------	-------	-------	-------	-------------

Radar ACK (success):

FD FC FB FA	04 00	A9 01	00 00	04 03 02 01
-------------	-------	-------	-------	-------------

### 2.2.16 Distance resolution setting

Set the distance resolution of the module, that is how far away each distance gate represents, the configuration value is not lost when power is lost, and the configuration value takes effect after restarting the module.

Can be configured to 0.75m or 0.2m per distance gate, the maximum number of distance gates supported are 8.

Command word: 0x00AA

Command value: 2-byte distance resolution selection index

Return value: 2-byte ACK status (0 success, 1 failure)

**Table 8 Distance resolution selection**

Distance resolution selection index value	Distance resolution (distance represented by each distance gate)
0x0000	0.75m
0x0001	0.2m

Factory default value is 0x0001, which is 0.75m.

Send data:

<b>FD FC FB FA</b>	<b>04 00</b>	<b>AA 00</b>	<b>01 00</b>	<b>04 03 02 01</b>
--------------------	--------------	--------------	--------------	--------------------

Radar ACK (success):

<b>FD FC FB FA</b>	<b>04 00</b>	<b>A1 01</b>	<b>00 00</b>	<b>04 03 02 01</b>
--------------------	--------------	--------------	--------------	--------------------

### 2.2.17 Query distance resolution setting

Query the module's current distance resolution setting, i.e. how far away each distance gate represents.

Command word: 0x00AB

Command value: None

Return value: 2-byte ACK status (0 success, 1 failure) + 2-byte distance resolution selection index

Return value definition is the same as **Table 8 Distance resolution selection**

Send data:

<b>FD FC FB FA</b>	<b>02 00</b>	<b>AB 00</b>	<b>04 03 02 01</b>
--------------------	--------------	--------------	--------------------

Radar ACK (success):

<b>FD FC FB FA</b>	<b>06 00</b>	<b>AB 01</b>	<b>00 00</b>	<b>01 00</b>	<b>04 03 02 01</b>
--------------------	--------------	--------------	--------------	--------------	--------------------

Represents the currently set distance resolution of 0.2m.

## 2.3 Radar data output protocol

LD2410C outputs the radar detection result through serial port, the default output is basic target information, including target status, motion energy value, stationary energy value, motion distance, stationary distance and other information. If the radar is configured as engineering mode, the radar will additionally output each distance gate energy value (motion & stationary). Radar data is output in the prescribed frame format.

### 2.3.1 Reported data frame format

The format of the radar uplink message frames defined by the protocol is shown in Table 9 and Table 10. The definition of the report data type values in normal operation mode and engineering mode are shown in Table 11.

**Table 9 Reported data frame format**

Frame header	Length of data in the frame	Intra-frame data	End of frame
F4 F3 F2 F1	2 bytes	See Table 9	F8 F7 F6 F5

**Table 10 Intra-frame data frame format**

Data type	Head	Target data	Tail	Calibration
1 byte (See Table 10)	0xAA	See Table 11, Table 13	0x55	0x00

**Table 11 Data type description**

Data type value	Description
0x01	Engineering mode data
0x02	Target basic information data

### 2.3.2 Target data composition

The content of the target data reported by the radar will change depending on the operating mode of the radar. In normal operation mode, the radar outputs the basic information data of the target by default; when configured to engineering mode, the radar adds each distance gate energy value information after the basic information data of the target. Therefore, the basic information of the target will always be output in the radar report data, while the distance gate energy value information needs to be enabled by command to be output.

The composition of the target data reported by the radar in normal operation mode is shown in Table 11, and the definition of the target state values is shown in Table 12. The composition of the target data frame in engineering mode is shown in Table 13, with additional data added to the data reported in normal operation mode.

**Table 12 Target basic information data composition**

Target Status	Movement target distance (cm)	Exercise target energy value	Distance to stationary target (cm)	Stationary target energy value	Detection distance (cm)
1 byte (See Table 12)	2 bytes	1 byte	2 bytes	1 byte	2 bytes

**Table 13 Target state value description**

Target state value	Description
0x00	No target
0x01	Campaign target
0x02	Stationary target
0x03	Campaign & Stationary target

**Table 14 Engineering model target data composition**

Add the following data after the target basic information data in Table 11

...	Maximum movement distance door N	Maximum resting distance door N	Movement distance gate 0 energy value	...	Movement distance gate N energy value	Stationary distance gate 0 energy value	...	Stationary distance gate N energy value	Retain data, store additional information
...	1 byte	1 byte	1 byte	...	1 byte	1 byte	...	1 byte	M byte

### Example of reported data:

Data reported in normal operating mode:

Frame header	Length of data in frame	Intra-frame data	End of frame
F4 F3 F2 F1	0D 00	02 AA 02 51 00 00 00 00 3B 00 00 55 00	F8 F7 F6 F5

Data reported in engineering mode:

Frame header	Length of data in frame	Intra-frame data	End of frame
F4 F3 F2 F1	23 00	01 AA 03 1E 00 3C 00 00 39 00 00 08 08 3C 22 05 03 03 04 03 06 05 00 00 39 10 13 06 06 08 04 03 05 55 00	F8 F7 F6 F5

## 2.4 Radar command configuration method

### 2.4.1 Radar command configuration steps

The process of executing a configuration command by LD2410C radar consists of two parts: the upper computer "sends the command" and the radar "replies to the command ACK". If the radar does not reply with ACK or fails to reply with ACK, it means the radar fails to execute the configuration command.

As mentioned earlier, before sending any other commands to the radar, the developer needs to send the "enable configuration" command and then send the configuration command within the specified time. After the commands are configured, the "end configuration" command is sent to inform the radar that the configuration is finished.

For example, if you want to read the radar configuration parameters, first the host computer sends the "enable configuration" command; after receiving a successful radar ACK, then sends the "read parameters" command; after receiving a successful radar ACK, finally sends the "end configuration" command; after receiving successful radar ACK, it indicates that the complete action of reading parameters is finished.

The radar command configuration flow is shown in the following figure.

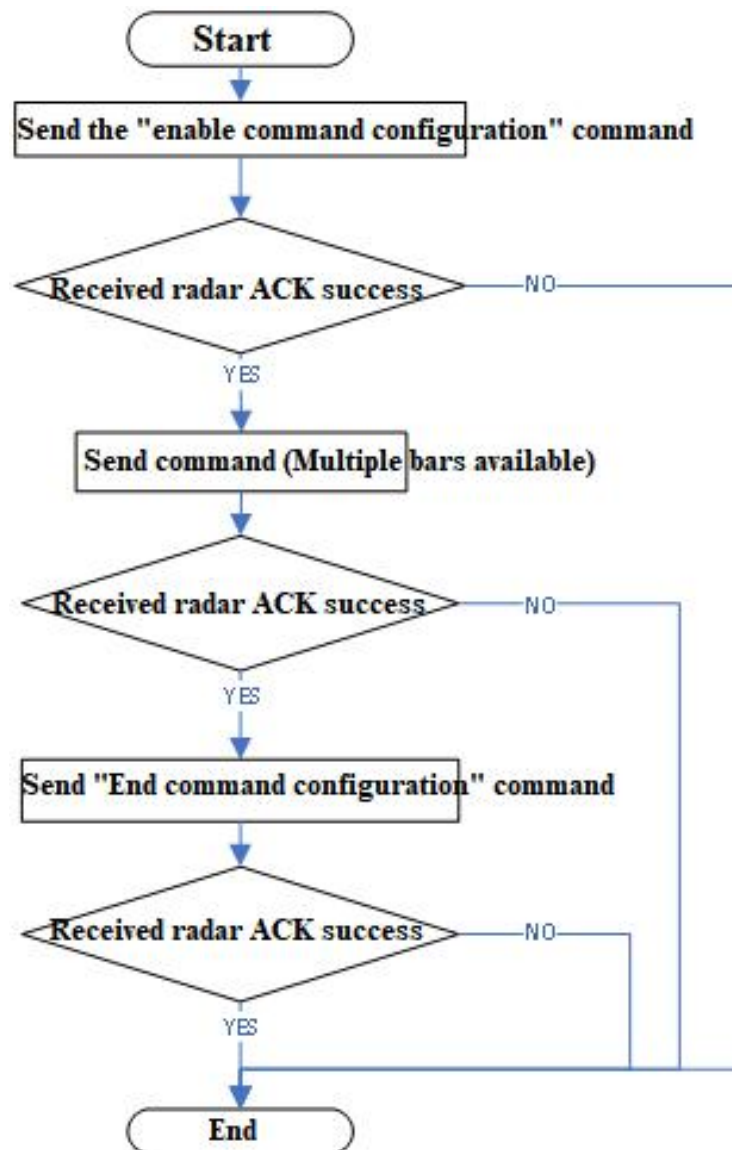

Figure 2 Radar command configuration process

### 3 Revision records

Data	version	Modify the content
2022-11-7	1.00	Initial version

#### 4 Technical support and contact information



### Shenzhen Hi-Link Electronic Co.,Ltd

Tel: 0755-23152658/83575155

Website: [www.hlktech.com](http://www.hlktech.com)

