

BOMAR[®]

Operating Instructions for Band Saw

individual 640.520 GH



Before transporting and using the machine, please read the instructions thoroughly!

Serial number:



Service and Information

In case of technical difficulties or spare parts order, please contact your dealer:

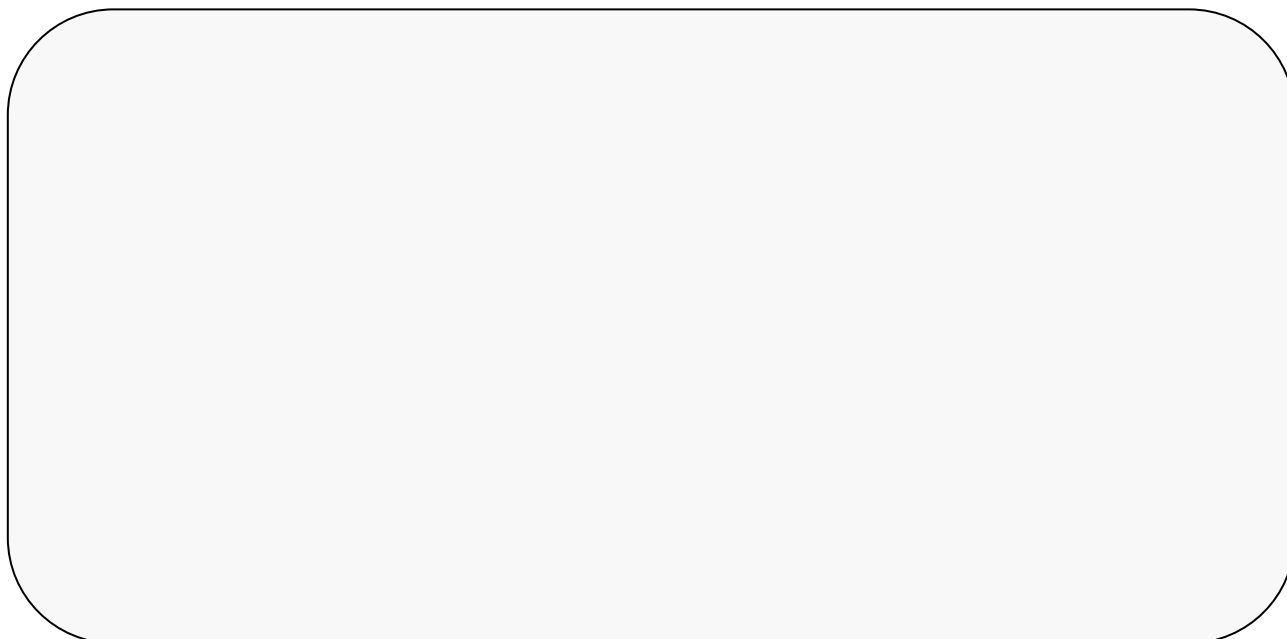

Or contact Bomar, spol. s r.o. directly:

BOMAR, spol. s r.o.

Těžební 1236/1

62700 Brno

CZECH REPUBLIC

Telephone: +420 – 533 426 100

Fax: +420 – 533 426 109

e-mail: info@bomar.cz

WWW: <http://www.bomar.cz>

We are available Mondays to Fridays from 7⁰⁰ to 16⁰⁰.

Content

1. INTRODUCTION	6
2. BAND SAW USING	6
3. TECHNICAL DATA.....	7
4. SAFETY NOTES	8
4.1. GENERAL	8
4.2. PROTECTIVE SUIT AND PERSONAL SAFETY.....	8
4.3. SAFETY NOTES FOR MACHINE OPERATOR	9
4.4. SAFETY NOTES FOR THE SERVICING AND REPAIRS	11
4.5. SAFETY MACHINE ACCESSORIES	11
5. TRANSPORTATION AND STOCKING	13
5.1. CONDITIONS FOR TRANSPORTATION AND STOCKING	13
5.2. SAFETY NOTES	13
5.3. TRANSPORT AND STOCKING PREPARATIONS	14
5.4. TRANSPORT AND STOCKING	14
6. ACTIVATION	15
6.1. MACHINE WORKING CONDITIONS.....	15
6.2. MACHINE INSTALLING AND LEVELLING	15
6.3. ELECTRICAL CONNECTION	16
6.4. FILLING OF THE COOLING SYSTEM.....	17
6.5. CHECK MACHINE FUNCTIONS	18
7. CONTROL PANEL – DESCRIPTION.....	19
8. STARTING THE BAND SAW.....	22
9. MATERIAL INSERTION.....	23
9.1. SAFETY NOTES	23
9.2. HANDLING AGENT SELECTION	23
9.3. MATERIAL INSERTION	23
9.4. BUNDLE MATERIAL CUTTING	24
10. BAND SAW ADJUSTING	25
10.1. SAFETY NOTES	25
10.2. ANGULAR CUT SETTING	25
10.3. CUTTING SPEED ADJUSTMENT	26
10.4. OPTIMAL ADJUSTING OF THE GUIDE CUBES SPAN	27
10.5. PRESSURE ADJUSTING TO THE CUT	27
11. SET MODE	28
11.1. ENTRANCE TO MENU	28
11.2. CUTTING PARAMETERS	28
11.3. VICE PARAMETERS (VICE OPENING)	28
11.4. STOP TIME OF THE HYDRAULICS	28
11.5. LANGUAGE VERSION SELECTION	29
11.6. MENU CLOSING	29
12. SEMI-AUTOMATIC CYCLE.....	30

12.1.	SAFETY NOTES	30
12.2.	CUTTING.....	30
12.3.	CYCLE BREAKING	32
12.3.1.	STOP button	32
12.3.2.	TOTAL STOP button.....	32
13.	BLANKS REMOVING FROM THE BAND SAW.....	33
13.1.	SAFETY NOTES	33
13.2.	HANDLING AGENT SELECTION	33
13.3.	BLANKS REMOVING	33
14.	SELECTION AND REPLACEMENT OF THE SAW BAND	34
14.1.	SAFETY NOTES	34
14.2.	SAW BAND SIZES	34
14.3.	SELECTION OF THE SAW BAND TOOTH SYSTEM:	34
14.4.	SAW BAND RUNNING - IN	36
14.5.	SAW BAND DISMANTLING	37
14.6.	SAW BAND INSTALLATION	38
14.7.	SAW BAND STRETCHING AND INSPECTION.....	39
14.7.1.	Saw band stretching.....	39
14.7.2.	Saw band inspection	39
15.	COOLING AGENTS AND CHIPS DISPOSAL.....	40
15.1.	SAFETY NOTES	40
15.2.	COOLING LIQUID PREPARATION	40
15.3.	COOLANT DEVICE INSPECTION	42
15.4.	CHIPS DISPOSAL	42
16.	GREASES AND OILS.....	43
16.1.	GEARBOX OILS.....	43
16.2.	HYDRAULIC OILS	44
16.3.	LUBRICANT GREASES	44
17.	SERVICE.....	45
17.1.	MACHINE CLEANING	45
17.2.	LUBRICATION.....	45
17.3.	COOLING LIQUID INSPECTION.....	45
17.4.	HYDRAULIC OIL LEVEL CHECK	46
18.	ADJUSTMENT	47
18.1.	GUIDING CUBES ADJUSTMENT	47
18.2.	HARD METAL GUIDES ADJUSTMENT	47
18.3.	SAW BAND RUN ADJUSTMENT ON STRETCHING WHEEL	49
18.4.	BRUSH ADJUSTMENT	50
18.5.	LIMIT SWITCH SETTING OF THE SAW BAND STRETCHING	50
18.6.	LIMIT SWITCH OF THE SAW FRAME LOWER POSITION ADJUSTMENT.....	51
18.7.	ADJUSTMENT OF A THROTTLE VALVE	52
19.	WORN PIECES REPLACEMENT.....	53
19.1.	HARD METAL GUIDES REPLACEMENT	53
19.2.	ROUND BRUSH REPLACEMENT.....	54
19.3.	SAW BAND GUIDING ROLLERS REPLACEMENT	55
19.4.	STRETCHING WHEEL REPLACEMENT	57
19.5.	DRIVING WHEEL REPLACEMENT	59

19.6. COOLING PUMP REPLACEMENT	60
20. ROZMĚROVÉ SCHÉMA / AUFSTELLZEICHNUNG / INSTALLATION DIAGRAM	62
21. ELEKTRICKÁ SCHÉMATA / ELEKTROSCHEMAS / WIRING DIAGRAMS	63
22. KUSOVNÍK ELEKTROSOUČÁSTÍ / STÜCKLISTE DER ELEKTROTEILEN / PIECE LIST OF ELEKTROPARTS	67
23. HYDRAULICKÉ SCHÉMA / HYDRAULIKSCHEMA / HYDRAULIC DIAGRAM	68
24. VÝKRESY SESTAV PRO OBJEDNÁNÍ NÁHRADNÍCH DÍLŮ / ZEICHNUNGEN FÜR BESTELLUNG DER ERSATZTEILE / DRAWING ASSEMBLIES FOR SPARE PARTS ORDER	71
24.1. PÍLA / SÄGE / SAW	72
24.2. SVĚRÁK / SCHRAUBSTOCK / VICE	74
24.3. KONZOLA / KONSOLE / CONSOLE	76
24.4. ČELIST POMOCNÁ / HILFSBACKE / AUXILIARY JAW	78
24.5. SLOUP PŘEDNÍ / VORDERSÄULE / FRONT PILLAR	80
24.6. SLOUP ZADNÍ / HINTERE SÄULE / BACK POSTE	82
24.7. RAMENO / ARM / ARM	84
24.8. NAPÍNÁNÍ PILOVÉHO PÁSU / SÄGEBANDSPANNUNG / SAW BAND STRETCHING	86
24.9. VEDENÍ PÁSU / BANDFÜHRUNG / BAND GUIDING	88
24.10. PRAVÁ VODÍCÍ KOSTKA / RECHTER FÜHRUNGSKLOTZ / RIGHT GUIDING CUBE	90
24.11. LEVÁ VODÍCÍ KOSTKA / LINKER FÜHRUNGSKLOTZ / LEFT GUIDING CUBE	92
24.12. VÁLEC ZVEDACÍ / HEBEZYLINDER / LIFTING CYLINDER	94
24.13. KRYT PÁSU / SÄGEBANDABDECKUNG / SAW BAND COVER	96
24.14. KRYT VARIÁTORU / VARIATORDECKEL / VARIATOR COVER	98
25. TROUBLESHOOTING TABLE	100
26. ROLLER CONVEYORS AND ACCESSORIES	103
26.1. ROLLER CONVEYORS	103
26.2. ROLLER CONVEYORS PREPARED FOR POWERING	103
26.3. POWER AND CONTROL UNITS FOR POWERED CONVEYORS	104
26.4. LENGTH STOPS	105
26.5. CONNECTION PARTS	106
26.6. CONNECTION SETS	106
26.7. ACCESSORIES OF ROLLER CONVEYORS	106
26.8. COVERS	107
26.9. CONNECTION SCHEMA OF THE ROLLER CONVEYORS TO THE BAND SAW	108
DECLARATION OF CONFORMITY	111

20. Rozměrové schéma / Aufstellzeichnung / Installation diagram

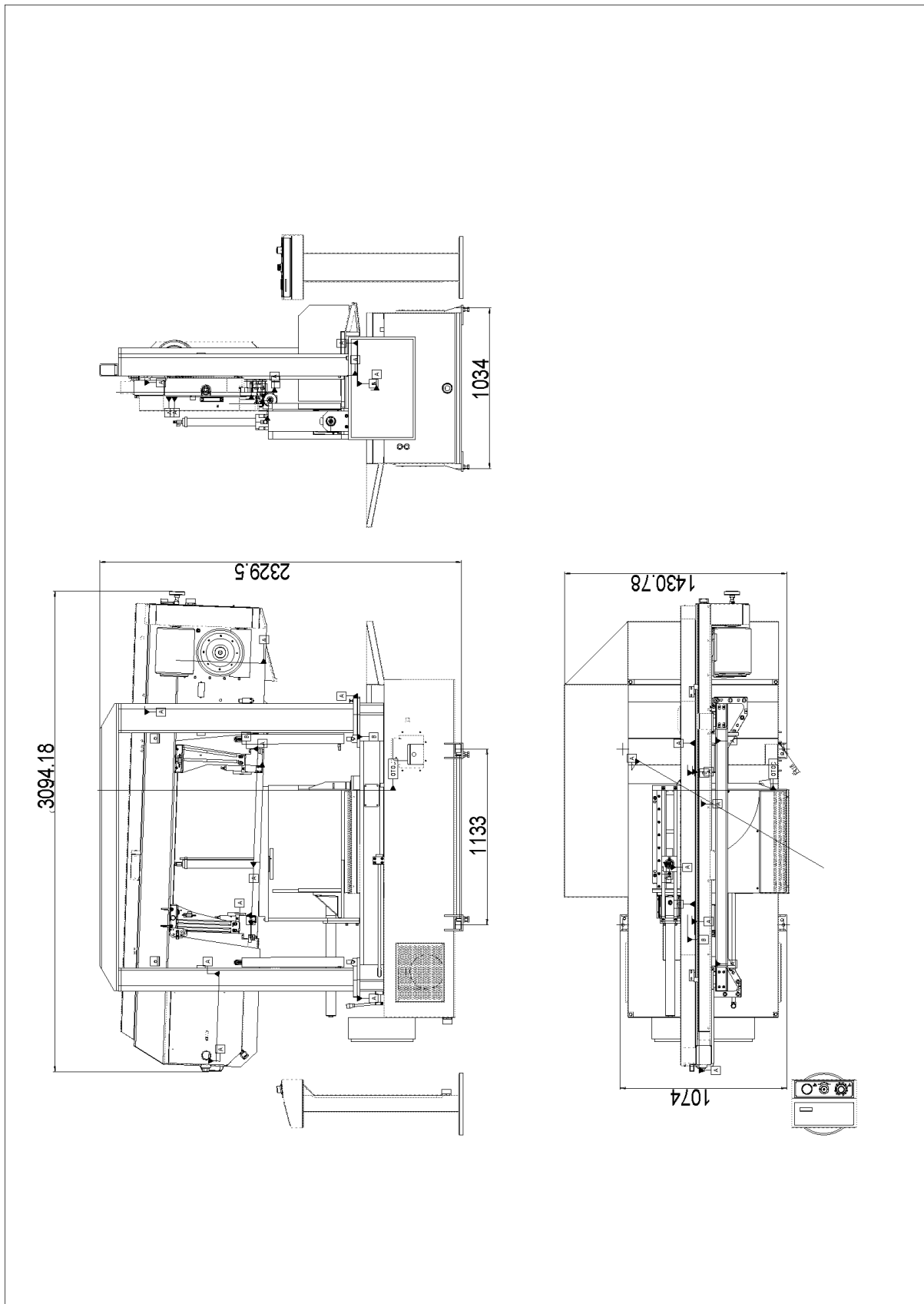

Rozměrové schéma / Aufstellzeichnung / Installation diagram – individual 640.520 GH

21. Elektrická schémata / Elektroschemas / Wiring diagrams

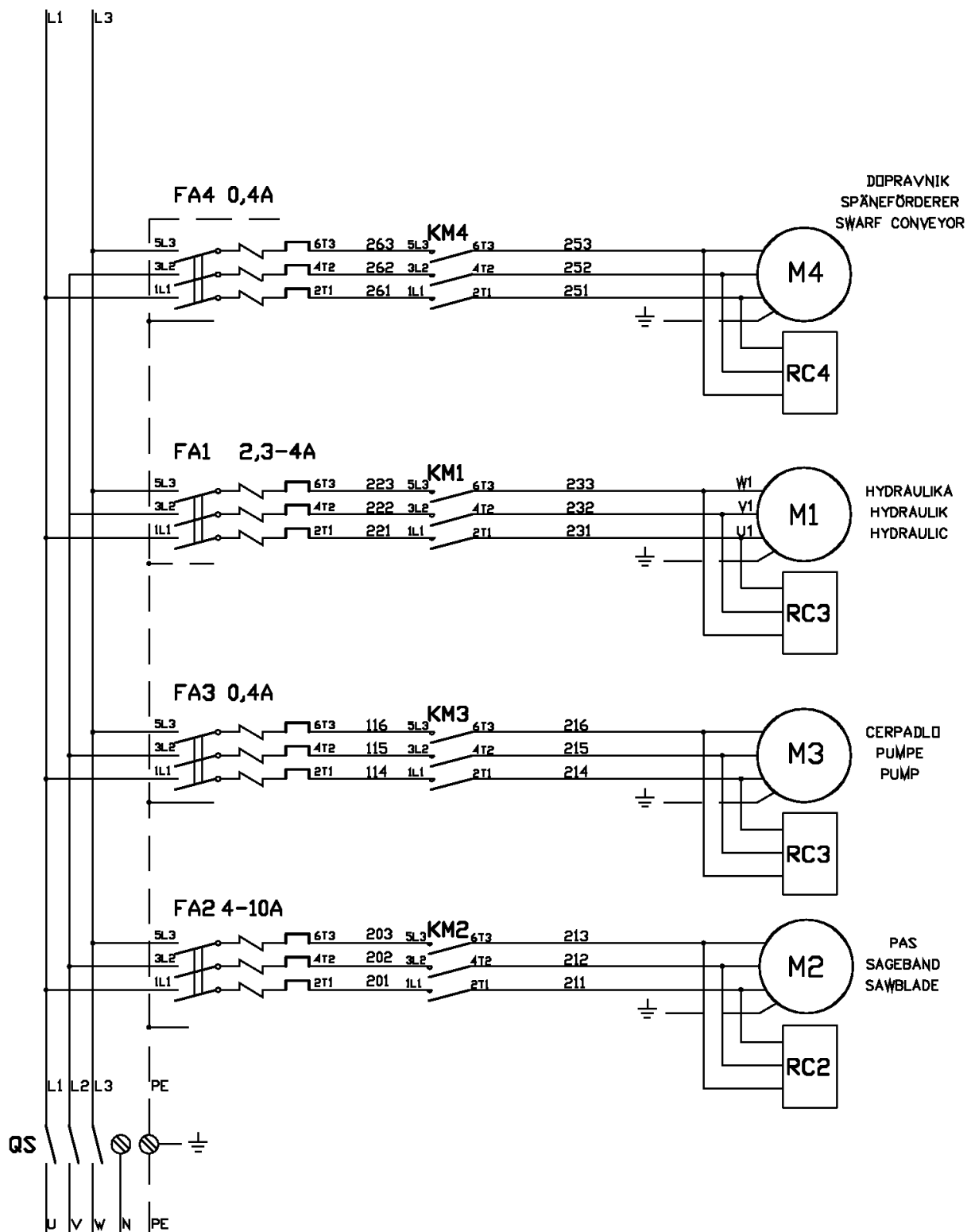

BOMAR	Individual xxx GH	ZDROJE, MOTORY	Datum: 10.9.2003	BOM5901
		STROMVERSORGUNGEN, MOTOREN		
		POWER SUPPLY, MOTORS	Firma: MKM	List: 01

Elektrické schéma 1 / Elektroschema 1 / Wiring diagram 1 – individual 640.520 GH

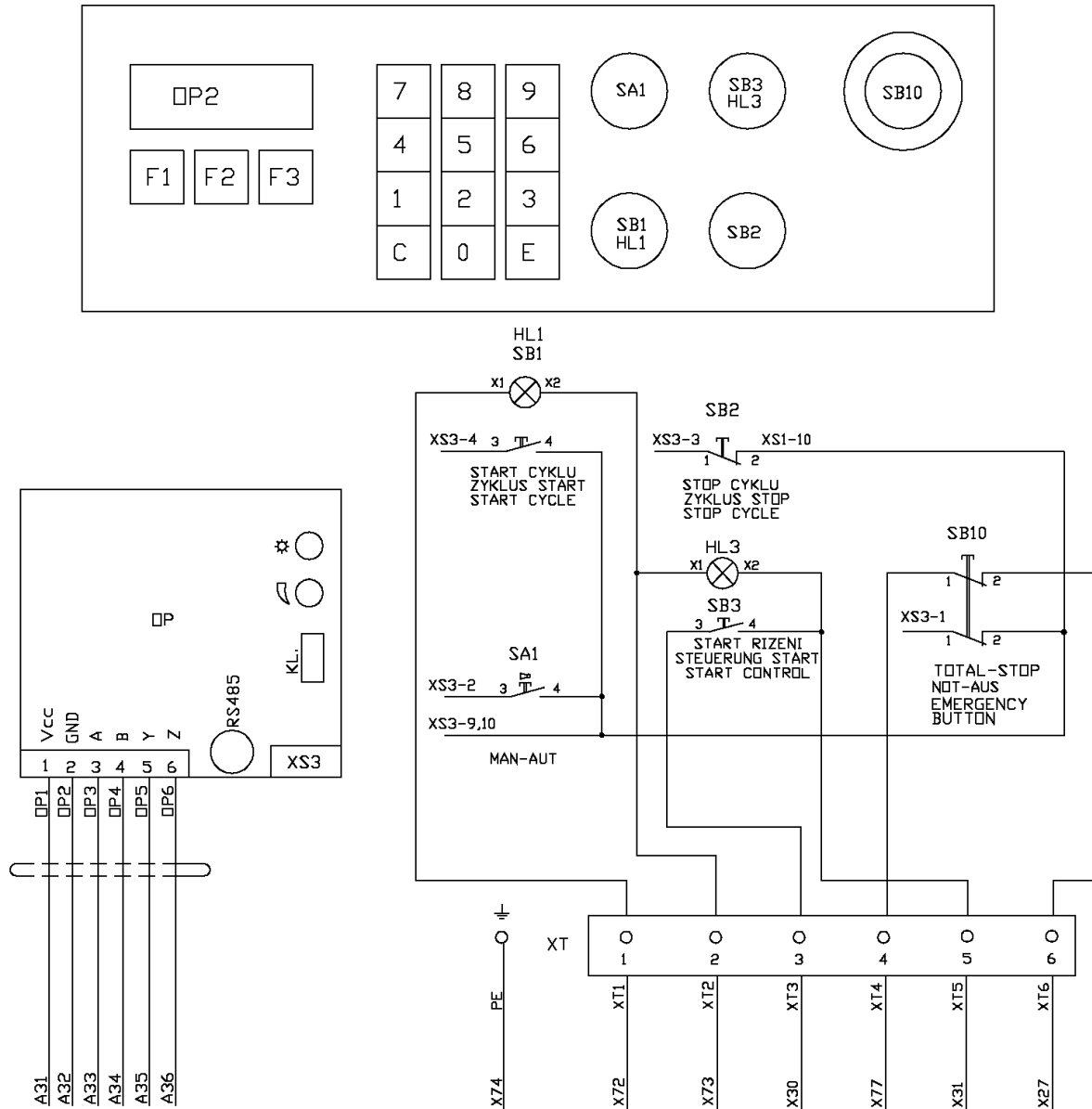

BOMAR	Individual xxx GH	TLACITKOVY PANEL	Datum: 10.9.2003	BOM5902
		BEDIENPULT		
		CONTROL PANEL	Firma: MKM	List: 02

Elektrické schéma 2 / Elektroschema 2 / Wiring diagram 2 – individual 640.520 GH

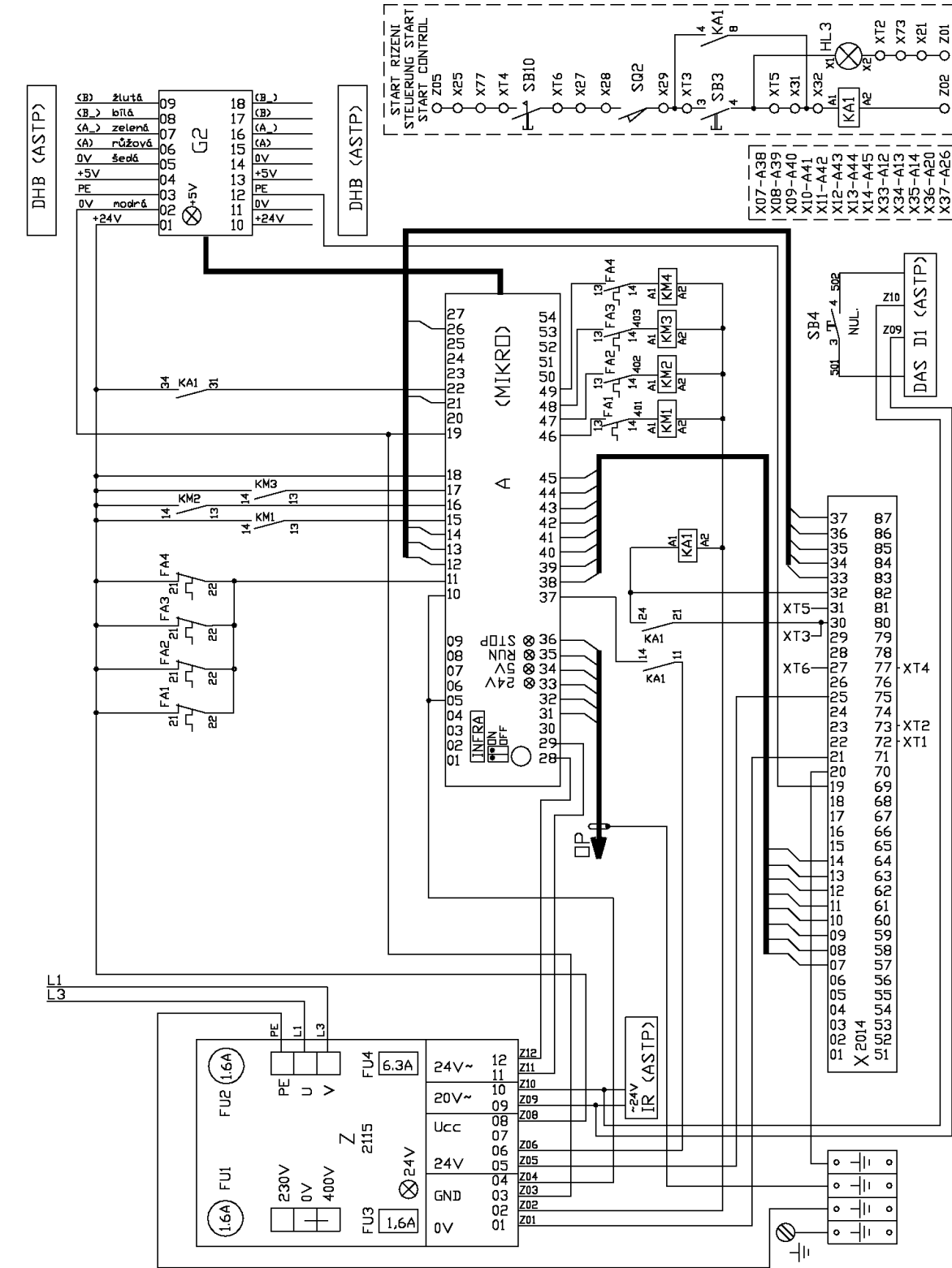

BOMAR	Individual xxx GH	ROZVADEC	Datum: 6.10.2005	BOM5903
		ELEKTROŠHRANK		
		CABINET	Firma: MKM	List: 03

Elektrické schéma 3 / Elektroschema 3 / Wiring diagram 3 – individual 640.520 GH

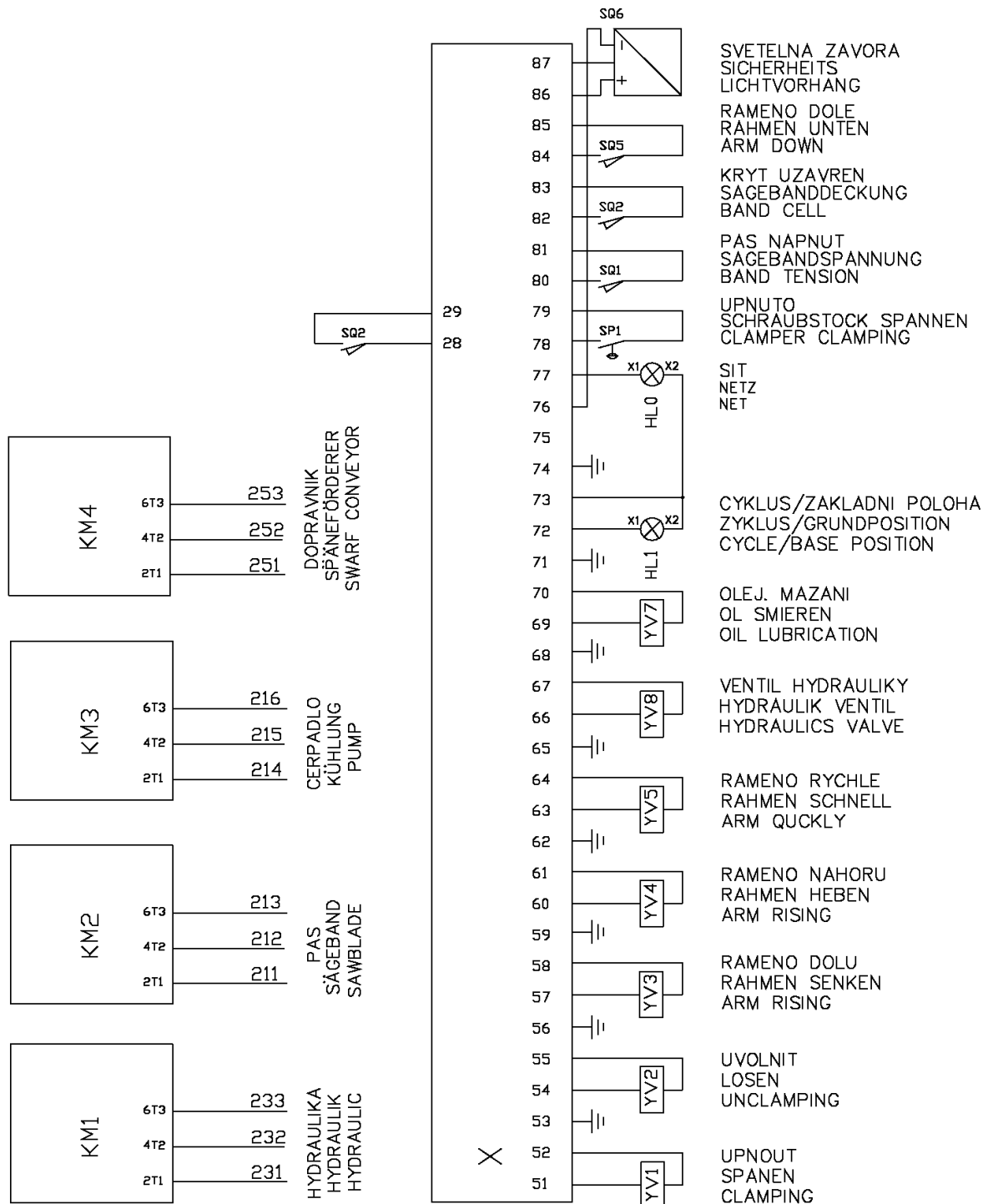

BOMAR	Individual xxx GH	VNEJSI PRIPOJENI	Datum: 10.9.2003	BOM5904
		EXTERN ANSCHLUB		
		EXTERNAL ADDITION	Firma: MKM	List: 04

Elektrické schéma 4 / Elektroschema 4 / Wiring diagram 4 – individual 640.520 GH

22. Kusovník elektrosoučástí / Stückliste der Elektroteilen / Piece list of electroparts

ATTENTION! Only qualified person can do the servicing and repairs. For parts changing, use only parts, which are identical with the originals.

Bestell - Nr.	Bezeichnung		Menge	Sign.
Objednáací číslo	Název položky		ks	Ozn.
Reference No.	Item		Pcs.	Sign.
91.995.056	Řídící jednotka / Steuereinheit / Control Modul		1	A
91.995.050	Displej / Display / Display	OP2	1	OP2
91.995.032	Modul / Modul / Modul	G2-1	1	G
91.310.001	Propojovací svorkovnice /Klemmleiste / terminal plate	4041	1	X
91.085.002	Zdroj /Generátor / Generator	2115	1	Z
91.040.004	Stykač / Schütz / contactor	LP1 KD910 BD3	6	KM
91.046.002	Pomocný kontakt / Hilfskontakt / Helping contact	ABBHKF1-11	3	FA
91.045.017	Motorový spouštěč / Motor Starter / Motor Starter	MS116--0,4A (u3x400V)	1	FA3
91.045.019	Motorový spouštěč / Motor Starter / Motor Starter	MS116-1,0A ABB (u3x400V)	1	FA4
91.045.022	Motorový spouštěč / Motor Starter / Motor Starter	MS116-4 A ABB u3x400V)	1	FA1
91.045.024	Motorový spouštěč / Motor Starter / Motor Starter	MS116 -10A ABB (u3x400V)	1	FA2
91.045.018	Motorový spouštěč / Motor Starter / Motor Starter	MS116 -0,63A ABB (u3x230V)	1	FA3
91.045.020	Motorový spouštěč / Motor Starter / Motor Starter	MS116-1,6 A ABB u3x230V)	1	FA4
91.045.023	Motorový spouštěč / Motor Starter / Motor Starter	MS116-6,3 A ABB u3x230V)	1	FA1
91.045.025	Motorový spouštěč / Motor Starter / Motor Starter	MS116 -16A ABB (u3x230V)		FA2
91.041.003	Odrušovač / Endstörer / Suppressor	FILTANA- F72450	4	RC
91.060.012	Hlavice TOTAL STOP / NOT-AUS Taste / TOTAL STOP button	ZB5-AS844	1	SB10
91.060.021	Tlačítko 2 polohy / Taste - 2Lage/ buton- 2 position	ZB5-AG4	1	SA1
91.060.019	Tlačítko zelené / Taste grün / buton green	ZB5-AW33	1	SB1
91.060.023	Tlačítko žluté / Taste gelb / buton yellow	ZB5-AW35	1	SB3
91.060.015	Tlačítko čeervené/ Taste rot / buton red	ZB5-AA4	1	SB2
91.060.013	Tlačítko černé / Taste schwarz / buton black	ZB5-AA2	1	SB4
91.3430-002	Rozvaděč / Schaltanlage / switchboard		1	

23. Hydraulické schéma / Hydraulikschema / Hydraulic diagram

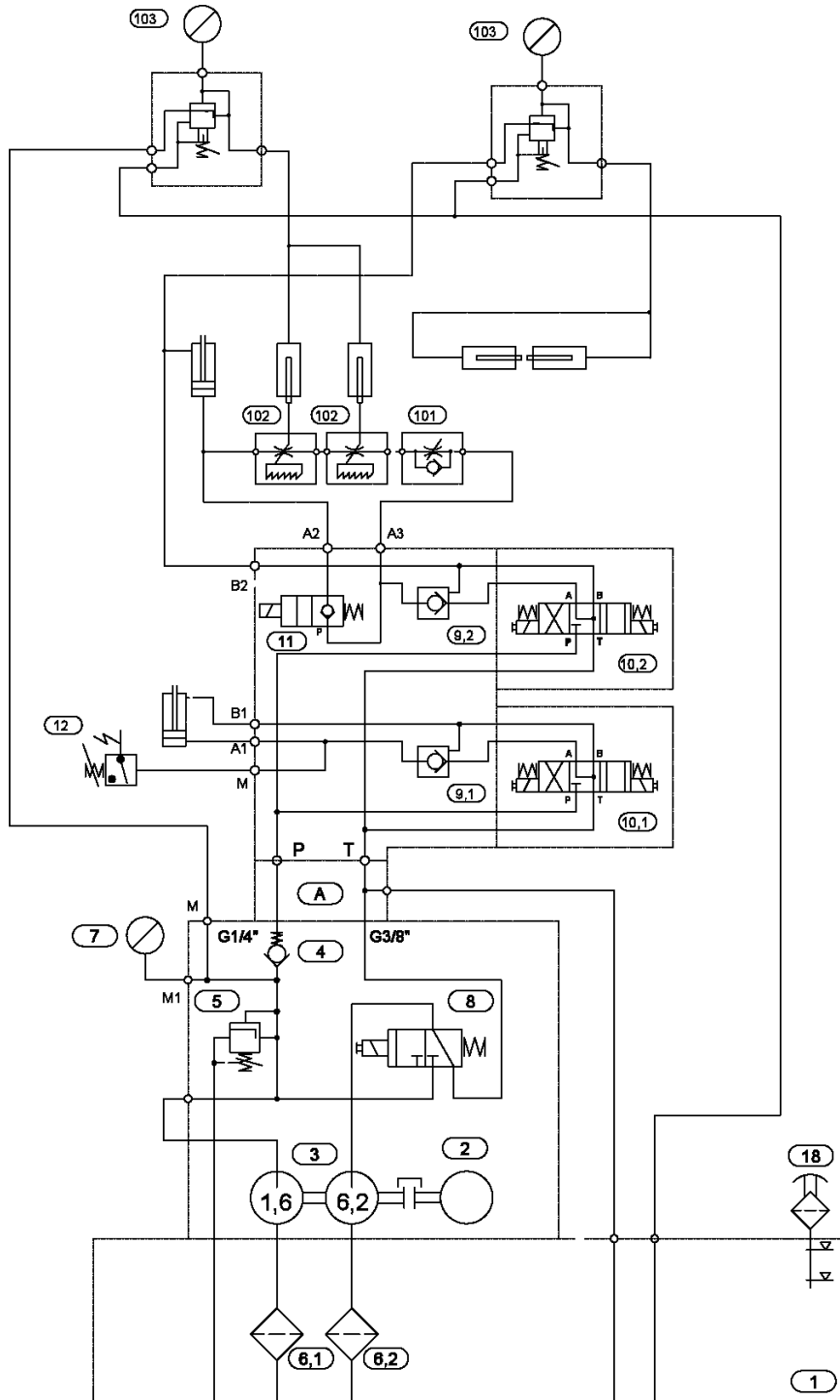

Základní technické parametry:

Technische Spezifikation:

Technical specification:

Q	8 + 2,1	dm ³ ·min ⁻¹	n	1410	min ⁻¹
P _{max}	4	MPa	P	1,1	kW

Hydraulické schéma:

Hydraulikschema:

Hydraulic diagram:

870-1554

Schéma / Schema / Diagram:

8701554A.DWG

Datum / Datum / Date:

19. 8. 2003

Hydraulické schéma / Hydraulikschema / Hydraulic diagram – individual 640.520 GH

Poz.	Název položky	ks
Pos.	Bezeichnung	Menge
Pos.	Item	Pcs.
1	Nádrž / Behälter / Tank	1
2	Elektromotor / Elektromotor / Electromotor MA-AL90S-4	1
3	Hydrogenerátor / Hydraulikaggregat / Hydrogenerator P2-6,2/1,6L.66313	1
4	Jednosměrný ventil / Einwegventil / One-way valve VJO1-06/SG-1	1
5	Přepouštěcí ventil / Bypassventil / By pass valve VPP2-04/S-6S	1
6	Filtr / Filter / Filter 2 SF 56/48-0.063	2
7	Manometr / Manometer / Manometer 68 - 0-10 MPa	1
8	Rozváděč / Verteilung / Distributor ROX1-042D21/02400E1K1	1
9	Hydraulický zámek / Hydraulisches Schloß / Hydraulic lock RJV1-05-0	2
10	Rozváděč / Verteilung / Distributor RPE3-043Y11/02400E1K1	2
11	Rozváděč / Verteilung / Distributor ROE3-042S2/02400E1K1	1
12	Tlakový spínač / Druckschalter / Pressure switch SUCO 0166 411 03 043	1
101	Škrtící ventil / Drosselventil / Throttle valve	1
102	Škrtící ventil / Drosselventil / Throttle valve	2
103	Redukční ventil / Reduzierventil / Pressure control valve VRN2-06/S-6R	2

Označení hydraulických hadiček / Bezeichnung der hydraulischen Schlauche / Indication of hydraulic hose:

Hydr. hadice	Hadice	Kování	Konc. A	Konc. B	Konc. C	Konc. D	Konc. E	Konc. F	Konc. G	Ks
Hydr. Schlauche	Schlauche	Schmieden	Schlauchtüle A	B	C	D	E	F	G	Menge
Hydr. Hose	hose	forging	terminal A	B	C	D	E	F	G	piece
6AE2700	42.001.001	92.051.001	92.052.001	-	-	-	93.012.004	-	-	1
6AA6460	42.001.001	92.051.001	92.052.001	-	-	-	-	-	-	1
6AE2700	42.001.001	92.051.001	92.052.001	-	-	-	93.012.004	-	-	1
6AA3000	42.001.001	92.051.001	92.052.001	-	-	-	-	-	-	1
6AA850	42.001.001	92.051.001	92.052.001	-	-	-	-	-	-	1
6AA1650	42.001.001	92.051.001	92.052.001	-	-	-	-	-	-	2
6AA6200	42.001.001	92.051.001	92.052.001	-	-	-	-	-	-	1
6AA8150	42.001.001	92.051.001	92.052.001	-	-	-	-	-	-	1
3AA2100	42.004.001	92.051.004	92.052.003	-	-	-	-	-	-	1
3AA900	42.004.001	92.051.004	92.052.003	-	-	-	-	-	-	1
3AA8150	42.004.001	92.051.004	92.052.003	-	-	-	-	-	-	1
3AA1000	42.004.001	92.051.004	92.052.003	-	-	-	-	-	-	1
3AA5850	42.004.001	92.051.004	92.052.003	-	-	-	-	-	-	1
3AA3000	42.004.001	92.051.004	92.052.003	-	-	-	-	-	-	1
3AA1900	42.004.001	92.051.004	92.052.003	-	-	-	-	-	-	1
PZ										
6BA1700	42.001.001	92.051.001	92.052.001	92.053.001	-	-	-	-	-	2
6AA1300	42.001.001	92.051.001	92.052.001	92.053.001	-	-	-	-	-	2

24. Výkresy sestav pro objednání náhradních dílů / Zeichnungen für Bestellung der Ersatzteile / Drawing assemblies for spare parts order

Při objednávání náhradních dílů vždy uvádějte: typ stroje (např. STG 120), výrobní číslo (např. 125) a rok výroby (např. 1999).

In die Bestellung der Ersatzteile führen Sie immer an:
Maschinentyp (z. B. STG 120), Serien Nr. (z. B. 125) und
Baujahr (z. B. 1999).

For spare parts order, you must always to allege: type of
machine (for example STG 120), serial number (for example 125)
and year of construction (for example 1999).

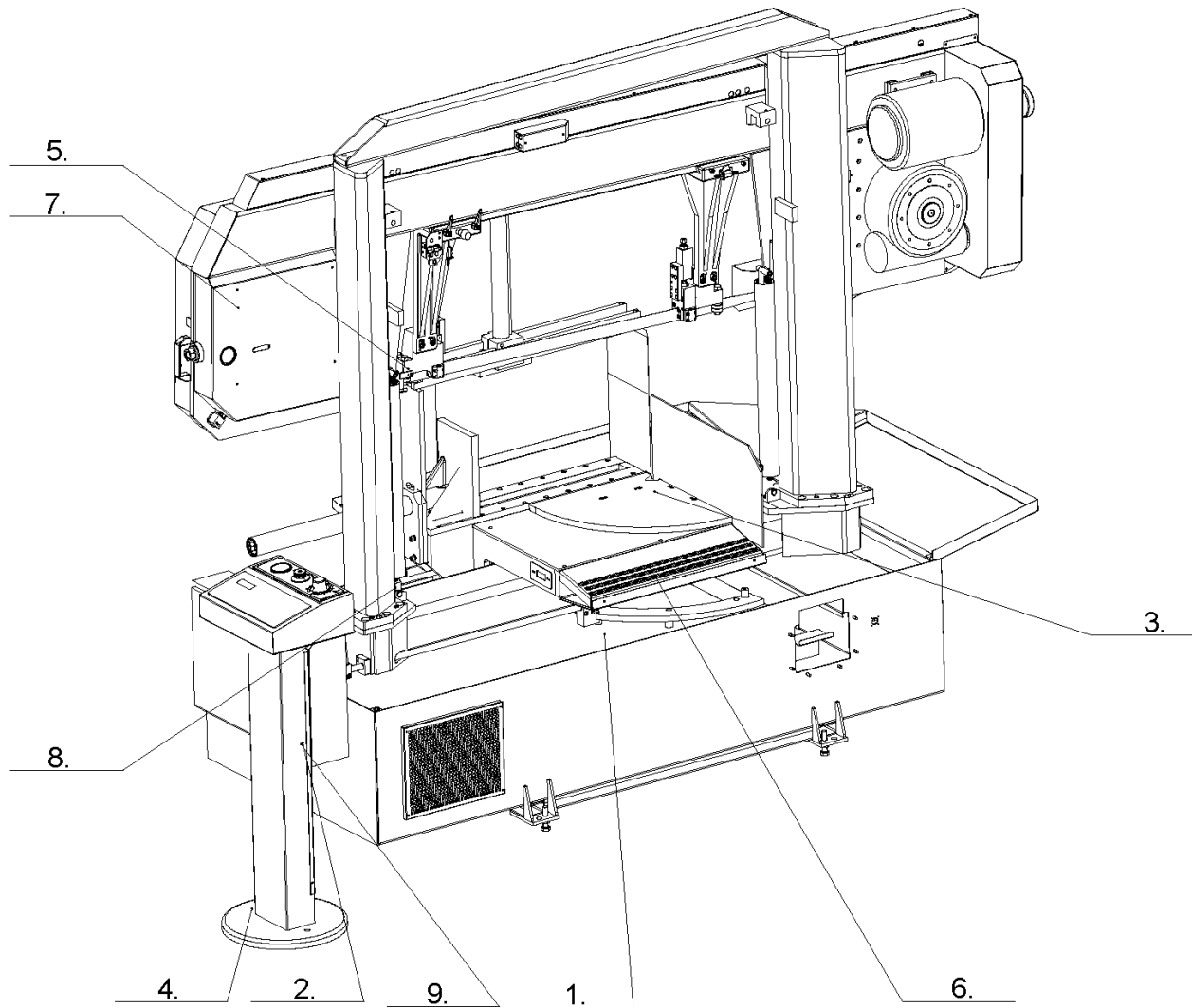

24.1. Pila / Säge / Saw

Poz.	Objednací číslo	Název položky	ks
Pos.	Bestell - Nr.	Bezeichnung	Menge
Pos.	Reference No.	Item	Pcs.
1.	201.2806-000	Chlazení / Kühlung / Cooling	1
2.	201.8801-000	Podstavec / Untergestell / Pedestal	1
3.	201.8803-600	Svěrák / Schraubstock / Vice	1
4.	201.8814-200	Ovládací pult / Bedienpult / Control panel	1
5.	201.8814-400	Horní upínání / Obere Spannung / Top clamping	1
6.	201.8902-600	Konzola / Konsole / Console	1
7.	201.8904-600	Rameno / Arm / Arm	1
8.	201.8907-600	Válec zvedací / Hebezyylinder / Lifting cylinder	2
9.	92.001.025	Agregát hydraulický / Hydraulische aggregate / Hydraulic aggregate	1

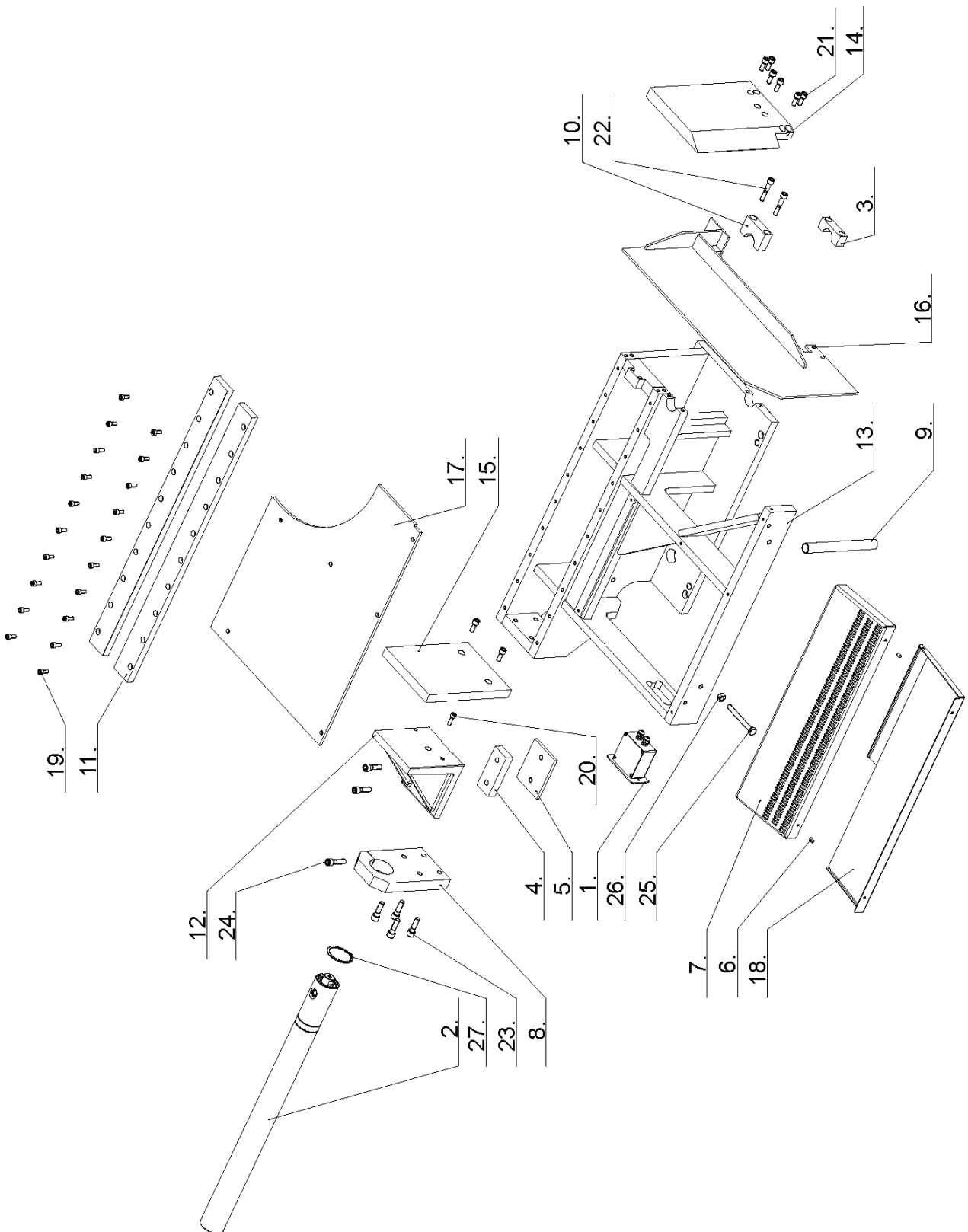

24.2. Svěrák / Schraubstock / Vice

Poz.	Objednací číslo	Název položky	ks
Pos.	Bestell - Nr.	Bezeichnung	Menge
Pos.	Reference No.	Item	Pcs.
1.	201.2903-100	Display / Display / Display	1
2.	201.4807-000	Válec / Zylinder / Cylinder	1
3.	30.0809-010	Příložka / Lasche / Splice plate	1
4.	30.1803-004	Kostka vodící / Führungsklotz / Guiding cube	1
5.	30.1803-005	Deska opěrná / Sohlplatte / Backing plate	1
6.	30.3509-015	Distanční trubka / Distanzrohr / Distance tube	2
7.	30.4803-014	Rošt / Gitter / Hake	1
8.	30.8503-016	Zadní deska / Hintere Platte / Back plate	1
9.	30.8603-008	Trubka / Rohr / Tube	1
10.	30.8603-015	Příložka / Lasche / Splice plate	1
11.	30.8803-007	Lišta vodící / Führungsleiste / Guiding listel	2
12.	30.8803-013	Čelist pohyblivá SG 440 / Bewegliche Backe / Movable jaw	1
13.	30.8803-101	Podstavec svěráku / Schraubstockständer / Vice pedestal	1
14.	30.8803-601	Čelist pevná / Feste Backe / Fixed jaw	1
15.	30.8803-602	Čelist pohyblivá / Bewegliche Backe / Movable jaw	1
16.	30.8803-603	Čelist pomocná / Hilfsbacke / Auxiliary jaw	1
17.	30.8903-012	Deska / Platte / Plate	1
18.	30.8903-020	Skluz / Rutsch / Glide	1
19.	90.001.25.032	Šroub imbus černěný / Schraube / Screw M8x20 DIN 912	20
20.	90.001.25.033	Šroub imbus černěný / Schraube / Screw M8x25 DIN 912	1
21.	90.001.25.047	Šroub imbus / Schraube / Screw M10x25 DIN 912	8
22.	90.001.25.053	Šroub imbus / Schraube / Screw M10x55 DIN 912	2
23.	90.001.25.060	Šroub imbus / Schraube / Screw M12x40 DIN 912	6
24.	90.001.25.061	Šroub imbus / Schraube / Screw M12x45 DIN 912	1
25.	90.005.55.XXX	6 HR Šroub zin / Schraube / Screw M12x100	1
26.	90.100.55.007	Matice / Mutter / Nut DIN 934	1
27.	95.800.021	Pojistný kroužek / Sicherungsring / Retaining ring	1

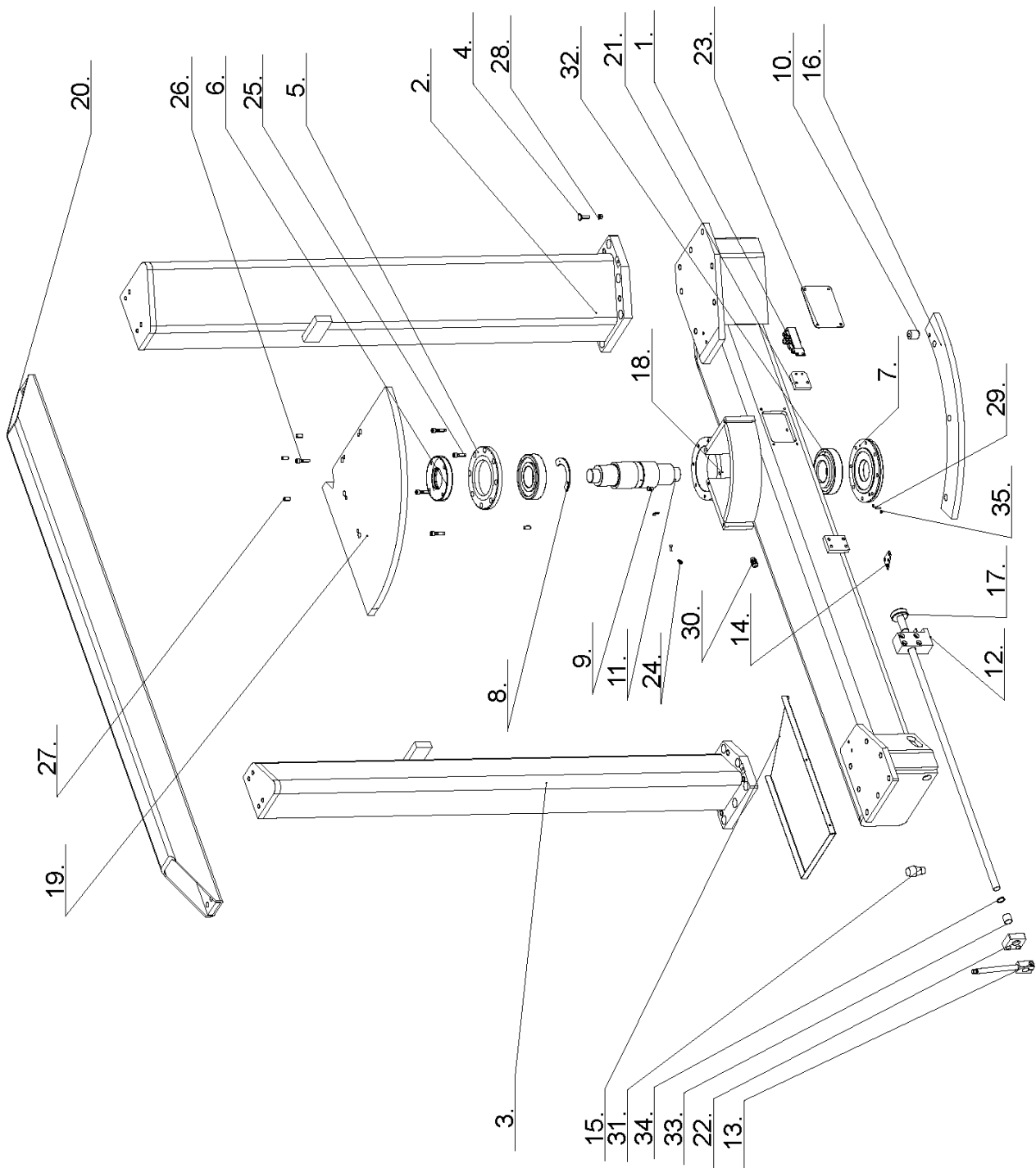

24.3. Konzola / Konsole / Console

Poz.	Objednáací číslo	Název položky	ks
Pos.	Bestell - Nr.	Bezeichnung	Menge
Pos.	Reference No.	Item	Pcs.
1.	201.2902-200	Snímač natáčení / Positionsgeber / Turning sensor	1
2.	201.8902-610	Sloup zadní / Hintere Säule / Back pillar	1
3.	201.8902-640	Sloup přední / Vorne Säule / Front pillar	1
4.	30.0702-013	Šroub / Schraube / Screw	1
5.	30.0802-004	Víko horní / Deckel / Upper cover	1
6.	30.0802-005	Matice ložiska / Lagermutter / Bearing nut	1
7.	30.0802-006	Víko spodní / Untendeckel / Lower cover	1
8.	30.2902-010	Ozubený segment / Zahnesegment / Tooth segment	1
9.	30.2902-112	Držák / Halter / Holder	2
10.	30.6014-209	Excentr / Exzenter / Eccentric	1
11.	30.8602-003	Čep konzoly / Bolzen / Console pivot	1
12.	30.8602-510	Kostka / Würfel / Cube	1
13.	30.8602-514	Tyč zpevnění / Stange / Hardening rod	1
14.	30.8602-521	Deska / Platte / Plate	1
15.	30.8602-524	Okapávací plech / Abtropfplatte / Drainage board	1
16.	30.8902-016	Segment / Segment / Segment	1
17.	30.8902-018	Tyč / Stange / Bar	1
18.	30.8902-501	Konzola / Konsole / Console	1
19.	30.8902-502	Kruhový segment / Ringsegment / Annular segment	1
20.	30.8902-504	Výztuha / Versteifung / Reinforcement	1
21.	30.8902-525	Držák / Halter / Holder	1
22.	30.8902-527	Držák brzdy / Bremsehalter / Brake holder	1
23.	81.8602-515	Kryt / Deckel / Cover	1
24.	90.001.25.008	Šroub imbus černěný / Schraube / Screw M5x12 DIN 912	2
25.	90.001.25.034	Šroub imbus / Schraube / Screw M8x30 DIN 912	4
26.	90.001.55.035	Šroub imbus černěný / Schraube / Screw M8x35 DIN 912	4
27.	90.002.2D.015	Stavěcí kužel / Stellkegel / Adjusting cone M10x20	4
28.	90.100.55.005	Matice / Mutter / Nut M8	1
29.	90.301.0Z.002	Kolík válcový / Zylinderstift / Cylindrical pin 5x16	1
30.	91.070.010	Vývodka / Ausführung / Bushing M12x1,5	1
31.	94.002.001	Hruška / Birne / Pear	1
32.	95.300.001	Kuželové ložisko / Lager / Roll bearing	2
33.	95.700.004	KU pouzdro / Büchse / Bush	1
34.	95.800.009	Pojistný kroužek / Sicherungsring / Retaining ring	1
35.	96.002.002	O kroužek / O Ring / O ring	3

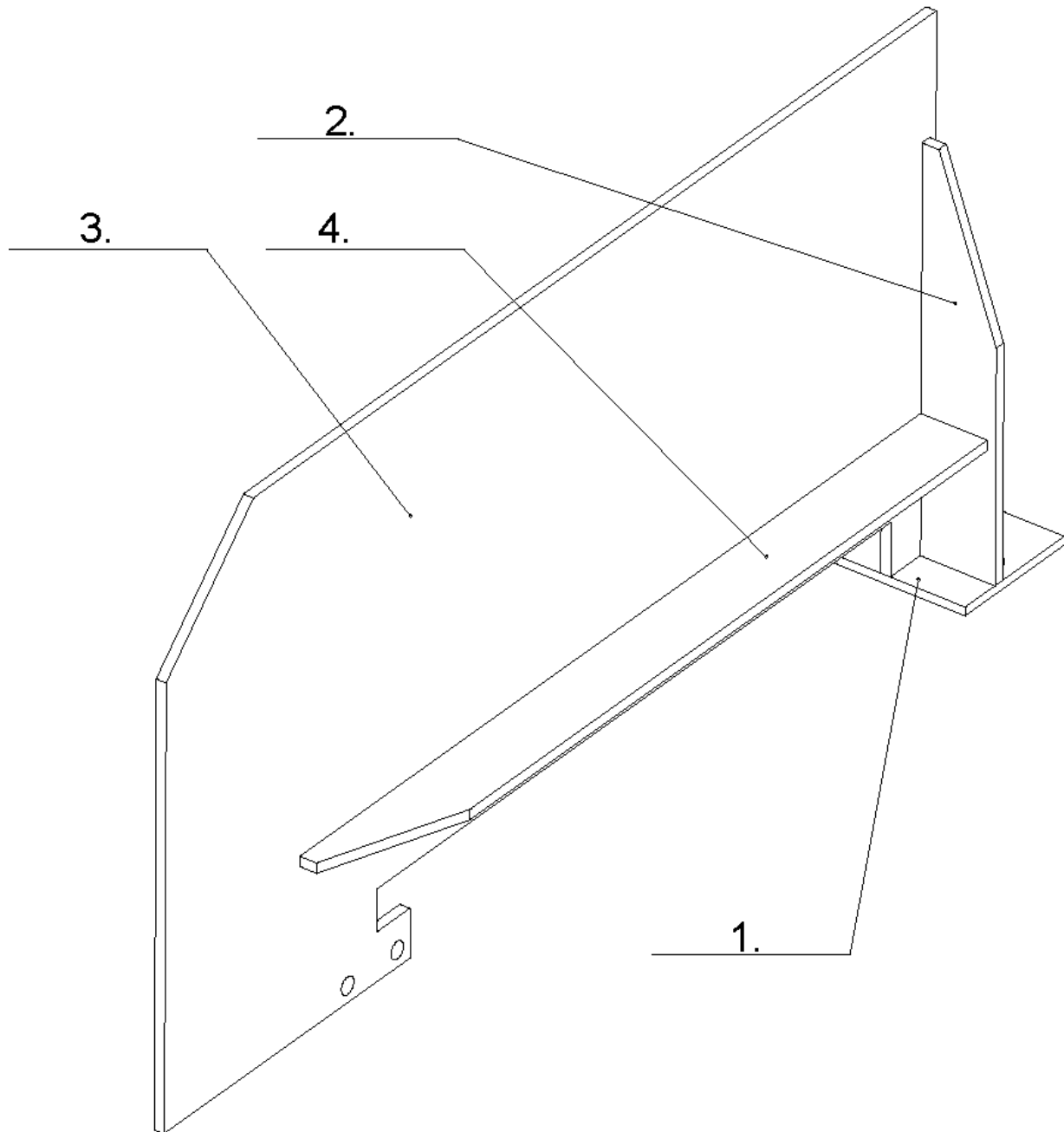

24.4. Čelist pomocná / Hilfsbacke / Auxiliary jaw

Poz.	Objednací číslo	Název položky	ks
Pos.	Bestell - Nr.	Bezeichnung	Menge
Pos.	Reference No.	Item	Pcs.
1.	30.8603-014-2	Základna / Grundlage / Base	1
2.	30.8803-014-3	Žebro / Rippe / Arris	1
3.	30.8803-603-1	Čelist pomocná / Hilfsbacke / Auxiliary jaw	1
4.	30.8903-014-4	Žebro / Rippe / Arris	1

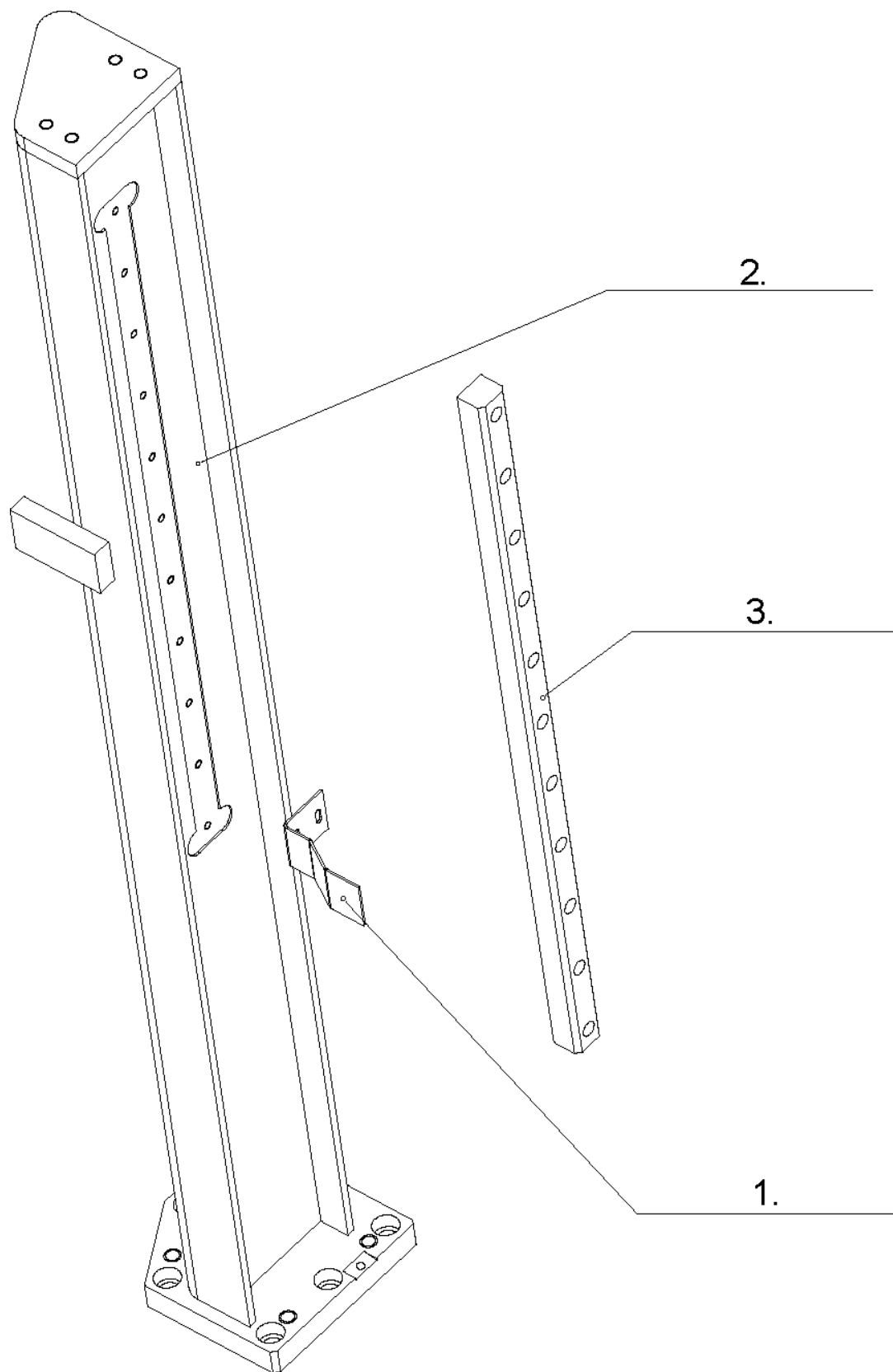

24.5. Sloup přední / Vordersäule / Front pillar

Poz.	Objednací číslo	Název položky	ks
Pos.	Bestell - Nr.	Bezeichnung	Menge
Pos.	Reference No.	Item	Pcs.
1.	30.8902-641	Sloup přední / Vordere Säule / Front Poste	1
2.	30.8902-024	Držák / Halter / Holder	1
3.	30.200.034	Vedení lineární / Linearführung / Linear Guide	1

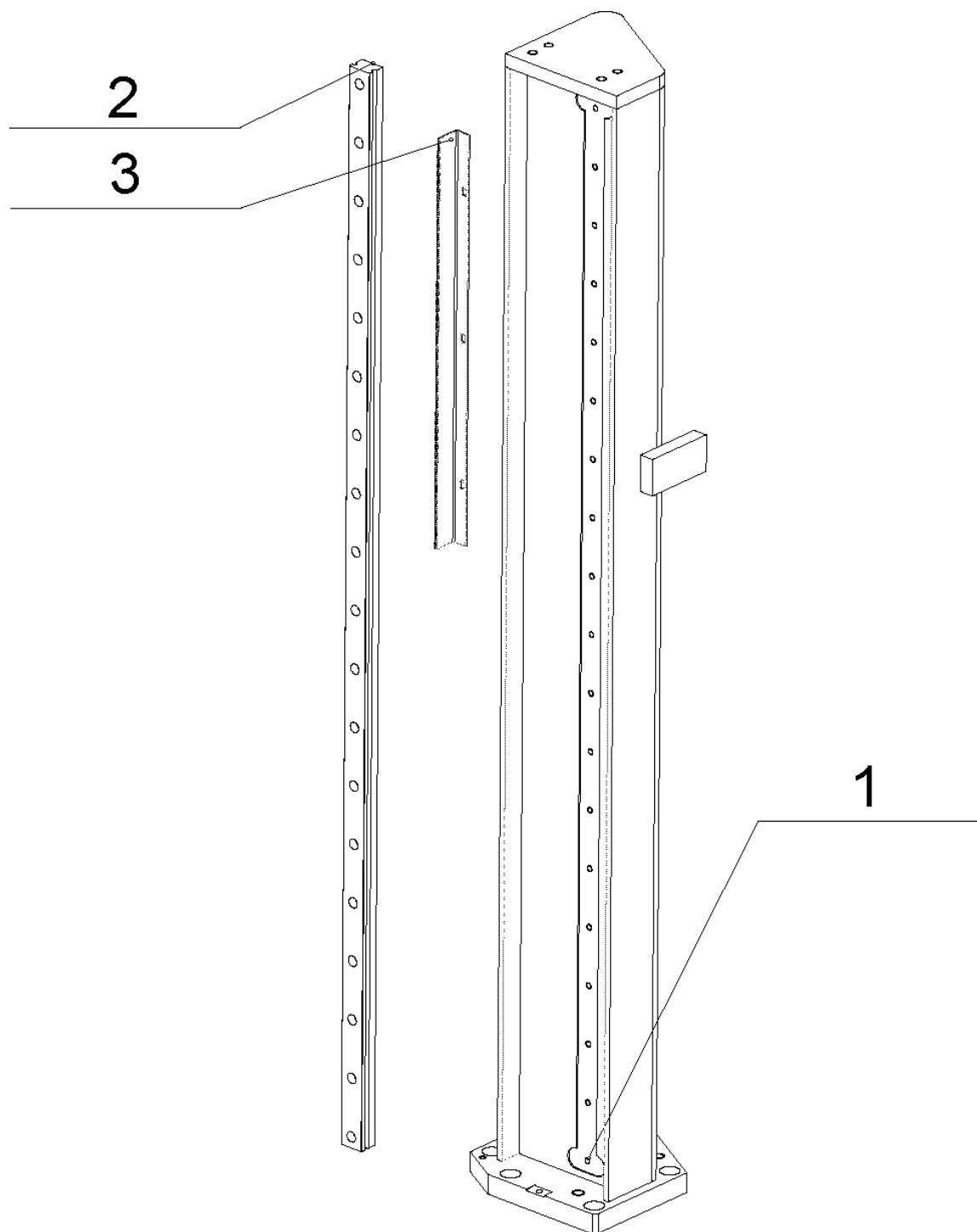

24.6. Sloup zadní / Hintere Säule / Back poste

Poz.	Objednací číslo	Název položky	ks
Pos.	Bestell - Nr.	Bezeichnung	Menge
Pos.	Reference No.	Item	Pcs.
1	30.8902-614	Sloup zadní / Hintere Säule / Back poste	1
2	99.200-061	Vedení lineární / Linearführung / Linear Guide LGR-1475e=2	1
3	30.8902-611	Hřeben / Kamm / Comb 3x5.6x562	1

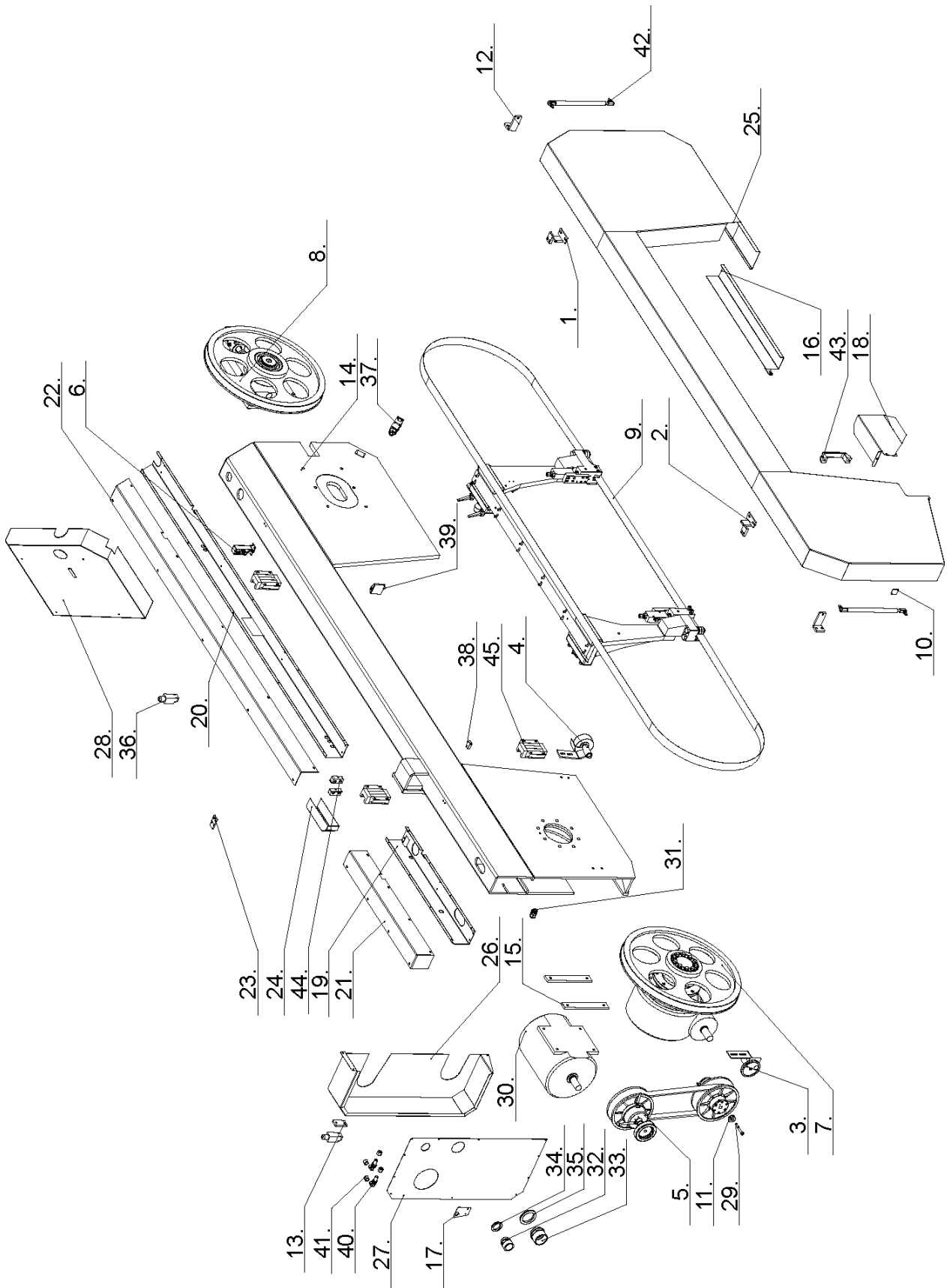

24.7. Rameno / Arm / Arm

Poz.	Objednáací číslo	Název položky	ks
Pos.	Bestell - Nr.	Bezeichnung	Menge
Pos.	Reference No.	Item	Pcs.
1.	201.1714-300	Pant levý / Türband / Left Hinge	1
2.	201.1714-400	Pant pravý / Türband / Right Hinge	1
3.	201.2914-400	Řemenice / Riemenscheibe / Band - wheel	1
4.	201.2914-700	Kartáček / Bürste / Brush	1
5.	201.6005-100	Variátor / Variator / Variator	1
6.	201.6702-200	Snímač natáčení / Positionsgeber / Turning sensor	1
7.	201.8905-200	Pohon / Antrieb / Drive	1
8.	201.8908-200	Napínání / Spannung / Stretching	1
9.	201.8910-600	Vedení pásu / Bandführung / Band guiding	1
10.	30.0814-113	Plech / Blech / Metal plate	1
11.	30.2914-401	Řemenice kartáčku / Riemenscheibe / Band - wheel	1
12.	30.7114-157	Držák / Halter / Holder	2
13.	30.8414-005	Držák koncového spínače / Endschalterhalter / Limit switch holder	1
14.	30.8804-201	Rameno / Arm / Arm	1
15.	30.8904-207	Lišta / Leiste / Listel	2
16.	30.8914-110	Kryt pásu / Banddeckel / Band cover	1
17.	30.8914-113	Clona / Schürze / Shield	1
18.	30.8914-208	Kryt kartáčku / Bürstenabdeckung / Brush cover	1
19.	30.8914-212	Koryto / Rinne / Channel	1
20.	30.8914-213	Koryto / Rinne / Channel	1
21.	30.8914-214	Kryt / Deckel / Cover	1
22.	30.8914-215	Kryt / Deckel / Cover	1
23.	30.8914-216	Podložka / Scheibe / Washer	1
24.	30.8914-220	Kryt hadic / Deckel / Cover	1
25.	30.8914-603	Kryt pásu / Banddeckel / Band cover	1
26.	30.8914-609	Kryt variátoru / Variatordeckel / Variator cover	1
27.	30.8914-610	Víko / Deckel / Cover	1
28.	30.8914-618	Kryt napínání / Deckel / Stretching cover	1
29.	90.001.25.040	Šroub imbus / Schraube / Screw	M8x60 D
30.	91.001.021	Motor / Motor / Motor	1
31.	91.070.012	Vývodka kleštinová / Ausföhrung / Bushing	M20x1,5
32.	91.071.004	Vývodka PG29 / Ausföhrung / Bushing	1
33.	91.071.006	Vývodka PG48 / Ausföhrung / Bushing	1
34.	91.072.007	Matice PG29 / Mutter / Nut	1
35.	91.072.009	Matice PG48 / Mutter / Nut	1
36.	91.173.007	Koncový spínač / Endschalter / Limit switch	2
37.	91.173.012	Spínač / Schalter / Switch	1
38.	91.174.001	Senzor optický / Lichtsenzor / Optical sensor	1
39.	91.175.001	Odrazka / Reflexionsglas / Reflex reflector	1
40.	92.009.001	Průchodka úhlová / Tülle / Angle grommet	2
41.	92.013.001	Matice / Mutter / Nut	4
42.	93.004.004-5	Plynová vzpěra / Gasstrebe / Gas brace	2
43.	94.012.001	Rukojeť / Griff / Handle	1
44.	94.204.005	Držák hadice / Schlauchhalter / Hose holder	2
45.	99.201.002	Vozík lineárního vedení / Linearführungswagen / Linear guidance carriage	3

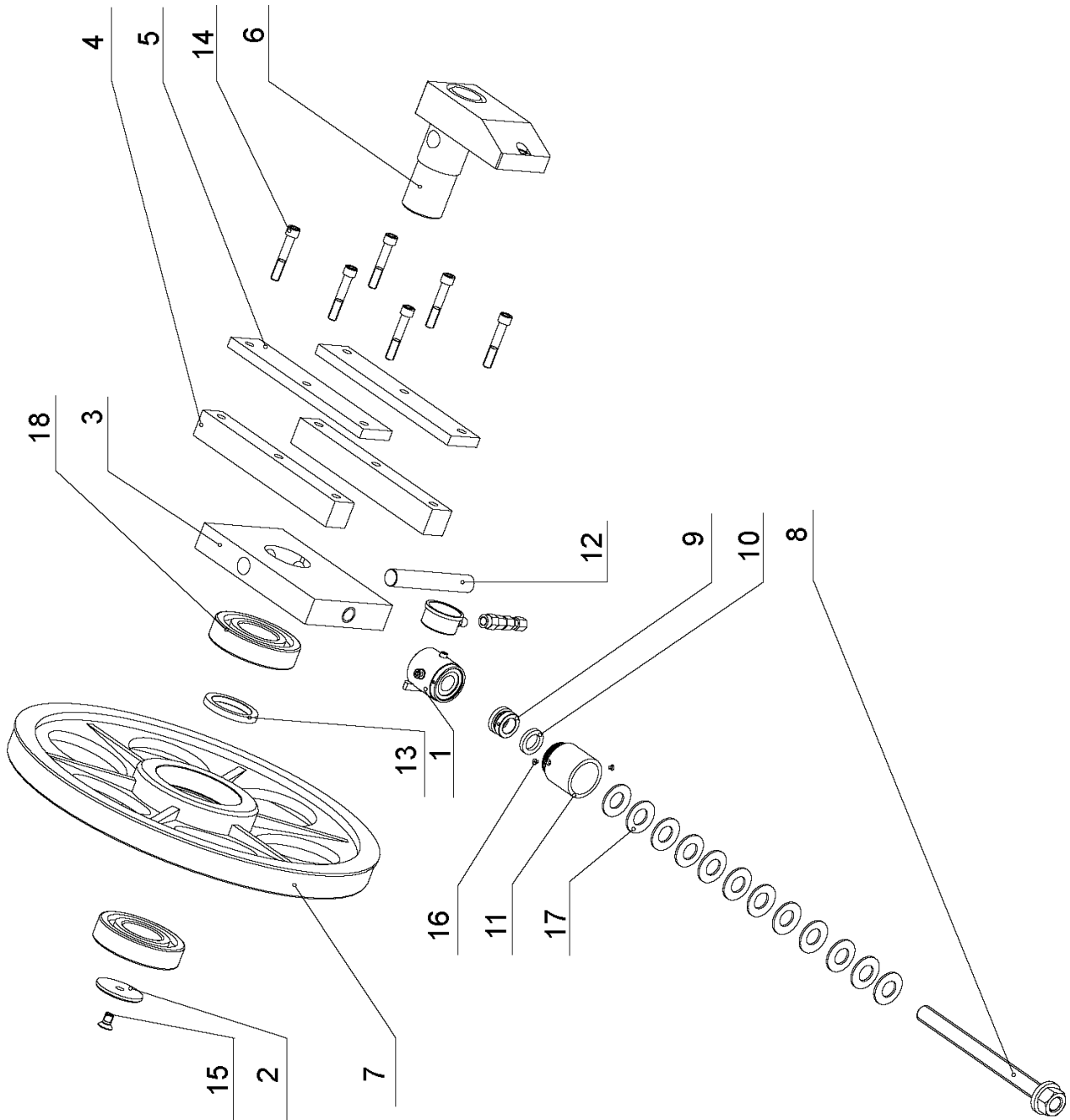

24.8. Napínání pilového pásu / Sägebandspannung / Saw band stretching

Poz.	Objednací číslo	Název položky	ks	
Pos.	Bestell - Nr.	Bezeichnung	Menge	
Pos.	Reference No.	Item	Pcs.	
1	201.6007-200	Válec snímání napnutí/ Zylinder Spannungsensor / Cylinder press sensor	1	
2	30.1804-010	Podložka / Scheibe / Washer	1	
3	30.6008-001	Kostka napínání / Bandspannungswürfel / Stretching cube	1	
4	30.6008-002	Lišta vodící / Führungsleiste / Guiding listel	2	
5	30.6008-003	Lišta vodící / Führungsleiste / Guiding listel	2	
6	30.6008-004	Napínání / Spannung / Stretching	1	
7	30.6008-006	Kolo napínací / Umlenkrad / Stretching wheel	1	
8	30.6008-008	Šroub napínání / Bandspannungsschraube / Stretching screw	1	
9	30.6008-011	Kroužek / Ring / Ring	1	
10	30.6008-012	Distanc / Distanz / Distance	1	
11	30.6008-013	Trubka / Rohr / Tube	1	
12	30.6008-014	Čep napínání / Spannungsbolzen / Stretching pivot	1	
13	30.6708-002	Trubka distanční / Distanzrohr / Distance tube	1	
14	90.001.25.064	Šroub / Schraube / Screw	M12x70	6
15	90.011.27.009	Šroub zápusťný/ Countersunk screw / Senkschraube	M12x20	1
16	90.011.27.018	Šroub zápusťný/ Countersunk screw / Senkschraube	M4x6	2
17	90.350.0Z.004	Pružina / Feder / Spring	50x25.4x3 DIN 2093	12
18	95.001.XXX	Pojistný kroužek / Sicherungsring / Retaining ring	6312A	2

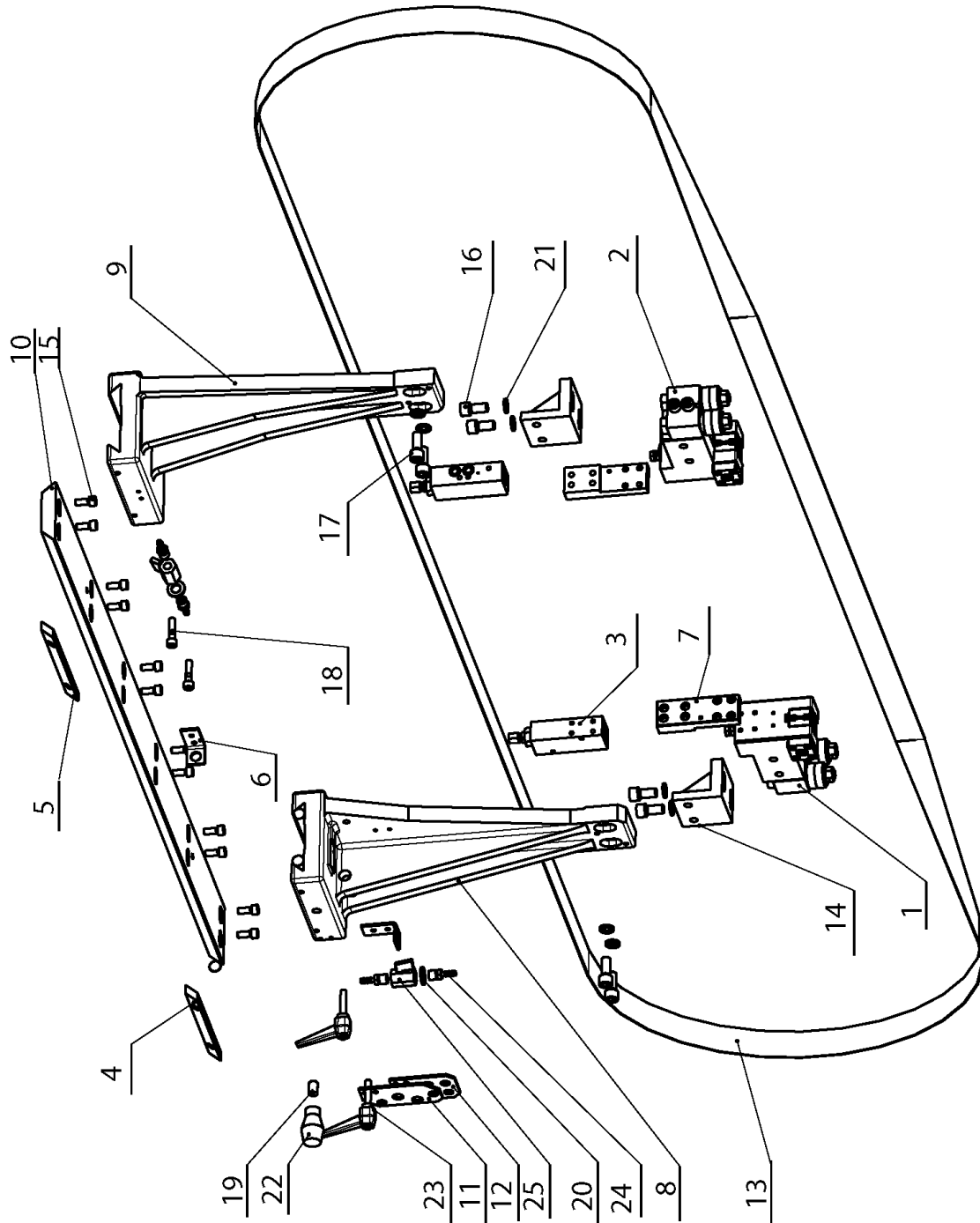

24.9. Vedení pásu / Bandführung / Band guiding

Poz.	Objednací číslo	Název položky		ks
Pos.	Bestell - Nr.	Bezeichnung		Men ge
Pos.	Reference No.	Item		Pcs.
1	201.6110-550	Kostka vodící L/ Führungsklotz / Guiding Cube		1
2	201.6110-610	Kostka vodící P / Führungsklotz / Guiding Cube		1
3	201.6816-100	Regulace řezu / Schnittdruckregulation / Pressure regulation		2
4	30.1810-004	Lišta držáku / Halterleiste / holder listel		1
5	30.1810-005	Lišta držáku / Halterleiste / holder listel		1
6	30.1814-011	Držák ventilu / Ventilhalter / Valve holder		2
7	30.6016-002	Deska / Platte / Plate		2
8	30.8910-001	Držák L / Linke Halter / Holder L		1
9	30.8910-002	Držák P / Rechte Halter / Holder right		1
10	30.8910-003	Lišta / Leiste / Listel		1
11	30.8910-004	Držák / Halter / Holder		1
12	30.8910-005	DržákL / Halter / Holder		1
13	30.8910-006	Pás / Band / Band		1
14	30.8910-601	Držák / Halter / Holder		2
15	90.001.25.032	Šroub / Schraube / Screw	8x20 DIN 912 8,8	12
16	90.001.25.057	Šroub / Schraube / Screw	M12x40 DIN 912 8,8	4
17	90.001.25.058	Šroub / Schraube / Screw	M12x30 DIN 912 8,8	4
18	90.001.55.035	Šroub / Schraube / Screw	M8x35 DIN 912 8,8	2
19	90.002.2D.018	Šroub stavěcí / Stellschraube / Setscrew	M12x20	1
20	90.150.50.007	Podložka / Scheibe / Washer	d13 DIN 125	2
21	90.163.00.003	Podložka / Scheibe / Washer	M12 D19,5	8
22	94.002.001	Hruška / Birne / Pear		1
23	94.008.003	Páka montážní / Hebel / Assembly lever	M8x40	2
24	94.202.002	Redukce / Reduktion / Reduction	G1/4-6	4
25	99.260.003	Ventil kulovy / Kugelventil / Ball valve	.1/4	2

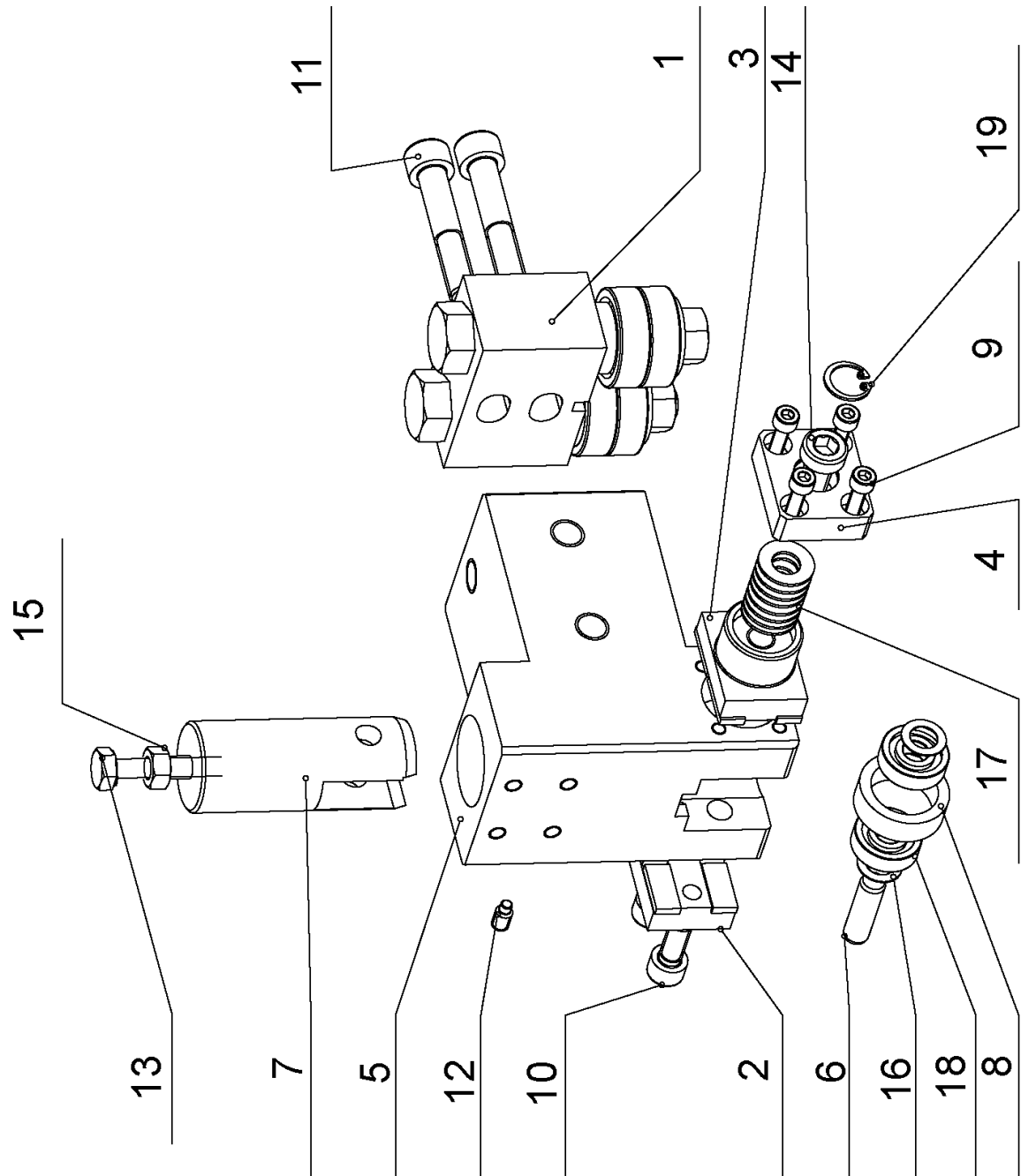

24.10. Pravá vodící kostka / Rechter Führungsklotz / Right guiding cube

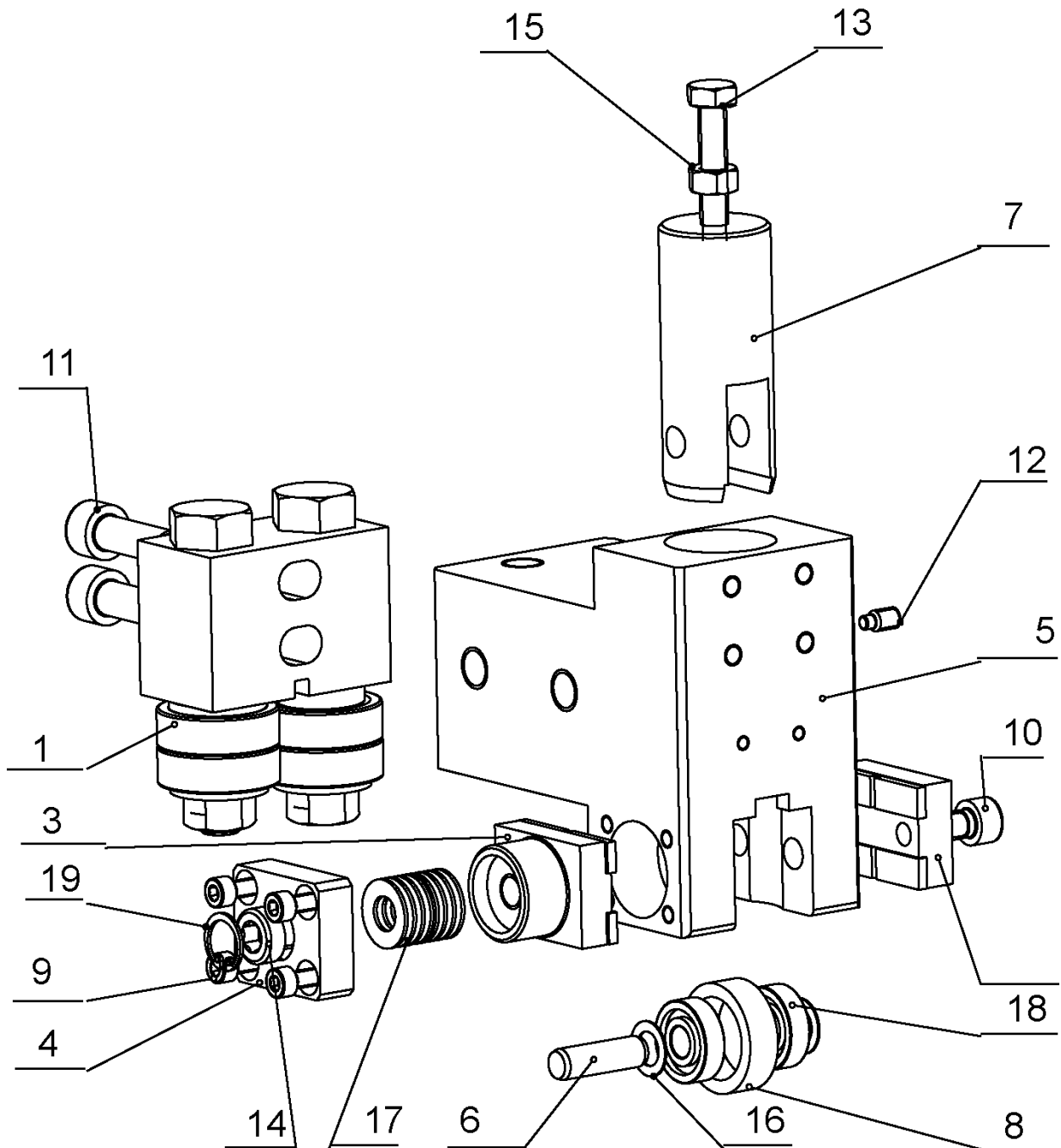
Poz.	Objednací číslo	Název položky		ks
Pos.	Bestell - Nr.	Bezeichnung		Menge
Pos.	Reference No.	Item		Pcs.
1	201.6110-510	Vedení / Führung / Guide		1
2	30.6010-105	Deska vodící / Führungsplatte / Guiding plate		1
3	30.6010-214	Deska vodící / Führungsplatte / Guiding plate		1
4	30.6010-218	Příložka / Lasche / Splice plate		1
5	30.6110-501	Kostka vodící pravá / Rechte Führungsplatte / Right guiding cube		1
6	30.6710-108	Kolík / Bolzen / Pin		1
7	30.6710-109	Píst / Kolben / Piston		1
8	30.6710-110	Kroužek / Ring / Ring		1
9	90.001.25.009	Šroub / Schraube / Screw	M5x16 DIN 912 8,8	4
10	90.001.25.032	Šroub / Schraube / Screw	8x20 DIN 912 8,8	2
11	90.001.25.053	Šroub / Schraube / Screw	M10x55 DIN 912 8,8	2
12	90.004.2D.002	Šroub stavěcí / Stellschraube / Setscrew	M6x12	1
13	90.005.55.019	šroub se šestihrannou hlavou / Sechskantschraube / Hex head screw	M8x40	1
14	90.015.25.010	Šroub / Schraube / Screw	M10x25 DIN 7984	1
15	90.100.55.005	Matice / Mutter / Nut	M8 DIN934	1
16	90.154.50.003	Podložka / Scheibe / Washer		2
17	90.350.0Z.004	Pružina / Feder / Spring	20x10.2x1.1 DIN 2093	8
18	95.001.044	Kuličkové ložisko / Kugellager / Ball bearing	609 2RS	2
19	95.801.035	Pojistný kroužek / Sicherungsring / Retaining ring		1

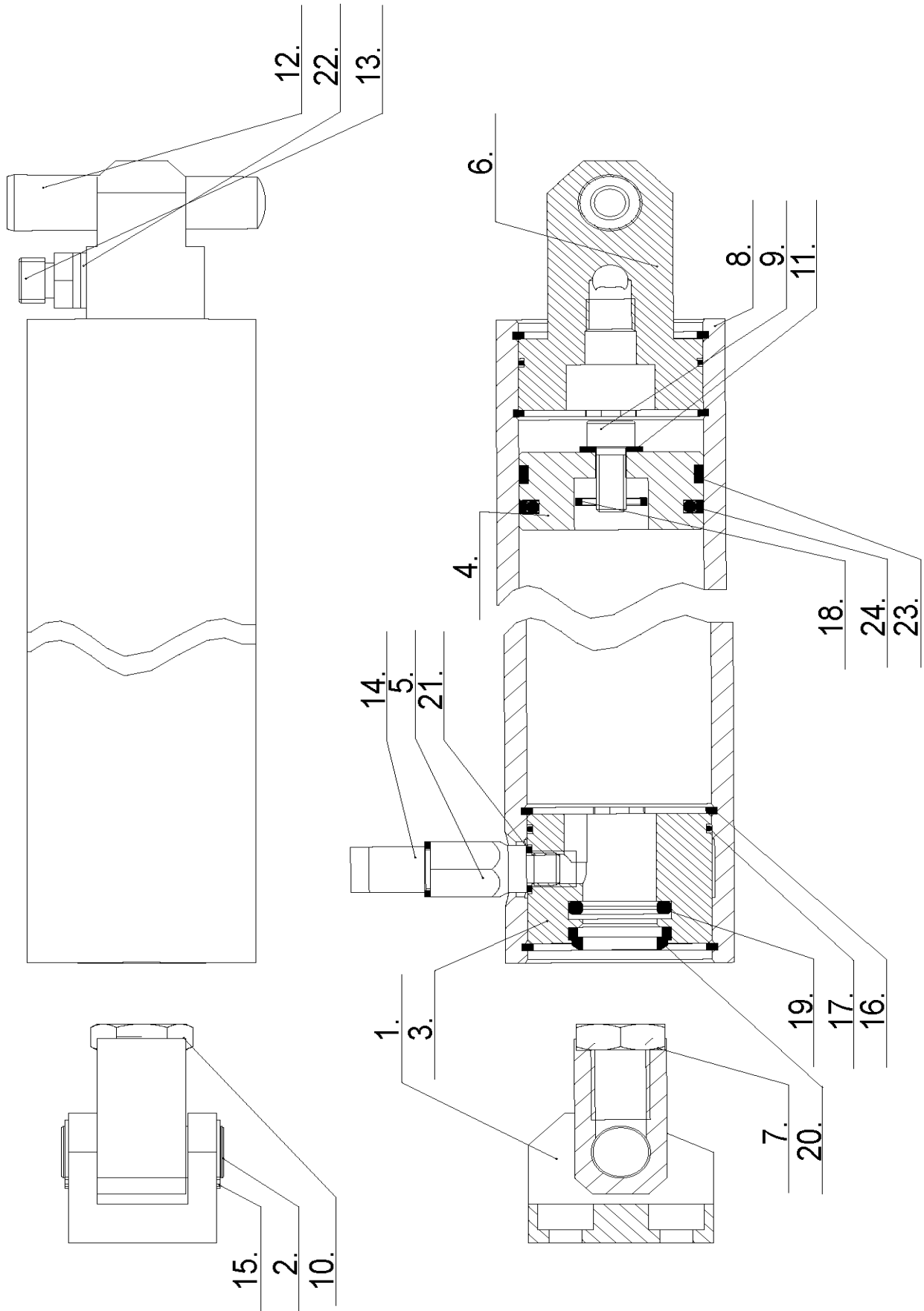

24.11. Levá vodící kostka / Linker Führungsklotz / Left guiding cube

Poz.	Objednací číslo	Název položky		ks
Pos.	Bestell - Nr.	Bezeichnung		Menge
Pos.	Reference No.	Item		Pcs.
1	201.6110-510	Vedení / Führung / Guide		1
2	30.6010-105	Deska vodící / Führungsplatte / Guiding plate		1
3	30.6010-214	Deska vodící / Führungsplatte / Guiding plate		1
4	30.6010-218	Příložka / Lasche / Splice plate		1
5	30.6110-501	Kostka vodící levá / Linke Führungsplatte / Left guiding cube		1
6	30.6710-108	Kolík / Bolzen / Pin		1
7	30.6710-109	Píst / Kolben / Piston		1
8	30.6710-110	Kroužek / Ring / Ring		1
9	90.001.25.009	Šroub / Schraube / Screw	M5x16 DIN 912 8,8	4
10	90.001.25.032	Šroub / Schraube / Screw	8x20 DIN 912 8,8	2
11	90.001.25.053	Šroub / Schraube / Screw	M10x55 DIN 912 8,8	2
12	90.004.2D.002	Šroub stavěcí / Stellschraube / Setscrew	M6x12	1
13	90.005.55.019	šroub se šestihrannou hlavou / Sechskantschraube / Hex head screw	M8x40	1
14	90.015.30.003	Šroub / Schraube / Screw	M10x25 DIN 6912	1
15	90.100.55.005	Matice / Mutter / Nut	M8 DIN934	1
16	90.154.50.003	Podložka / Scheibe / Washer	10x16x0,5 DIN 988	2
17	90.350.0Z.005	Pružina / Feder / Spring	20x10.2x1.1 DIN 2093	8
18	95.001.044	Kuličkové ložisko / Kugellager / Ball bearing	609 2RS	2
19	95.801.035	Pojistný kroužek / Sicherungsring / Retaining ring		1



24.12. Válec zvedací / Hebezyliner / Lifting cylinder

Poz.	Objednací číslo	Název položky	ks	
Pos.	Bestell - Nr.	Bezeichnung	Menge	
Pos.	Reference No.	Item	Pcs.	
1.	30.0807-008	Držák dolní / Untere Halter / Lower Holder	1	
2.	30.0807-009	Čep spodní / Untere Bolzen / Lower pivot	1	
3.	30.2807-002	Víko horní / Obere Deckel / Upper cover	1	
4.	30.2807-004	Píst / Kolben / Piston	1	
5.	30.3407-103	Redukce / Reduktion / Reduction	1	
6.	30.4107-003	Víko / Deckel / Cover	1	
7.	30.8607-001	Držák pístnice / Kolbenstangehalter / Piston rod holder	1	
8.	30.8907-601	Válec / Zylinder / Cylinder	1	
9.	90.001.25.032	Šroub imbus černěný / Schraube / Screw	M8x20 DIN 912	1
10.	90.101.55.003	Matice nízká / Mutter / Low Nut	M16	1
11.	90.150.50.005	Podložka / Scheibe / Washer	8,4 DIN 125	1
12.	90.302.0Z.012	Kuželový kolík+závit / Kegolbolzen+Gewinde / Taper pin +thread	16x70	1
13.	92.002.001	Šroubení / Schraubung / Screwing	G 1/4"	1
14.	92.004.001	Šroubení úhlové / Winkel Verschraubung / Angle screwing		1
15.	95.800.007	Pojistný kroužek / Sicherungsring / Retaining ring		2
16.	95.801.018	Kroužek pojistný vnitřní / Sicherungsring / Retaining ring		4
17.	96.001.013	O kroužek Dynamic / O Ring / O Ring	45x2	2
18.	96.002.007	O kroužek Dynamic / O Ring / O Ring	16x2	1
19.	96.041.002	Manžeta / Manschette / Sleeve	20/28x4	1
20.	96.060.002	Kroužek stírací / Abstreifring / Wiping ring	20x28	1
21.	96.082.001	Kroužek těsnící Cu / Dichtungsring / Sealing ring	10/14	1
22.	96.082.002	Kroužek těsnící Cu / Dichtungsring / Sealing ring	13/17	2
23.	96.084.001	Kroužek vodící / Führungsring / Guiding ring	50x5.5x2.5x146	1
24.	96.900.001	Těsnění kombinované / Dichtung / Sealing combined		1

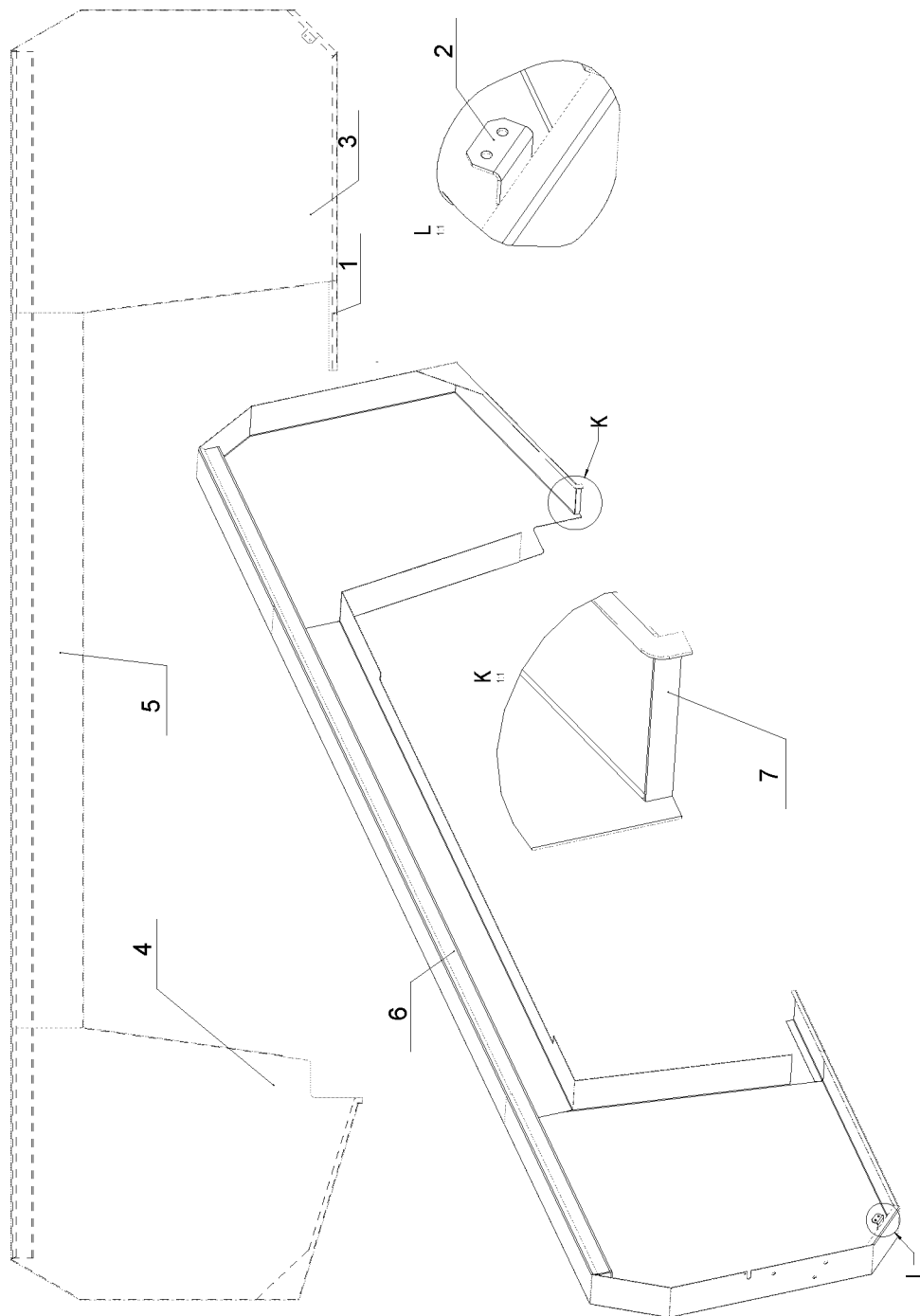

24.13. Kryt pásu /Sägebandabdeckung / Saw Band Cover

Poz.	Objednací číslo	Název položky	ks
Pos.	Bestell - Nr.	Bezeichnung	Menge
Pos.	Reference No.	Item	Pcs.
1	30.9814-203-5	Koryto / Rinne / Trough	1
2	30.9814-203-10	Držák / Halter / Bracket	1
3	30.9814-603-1	Kryt / Abdeckung / Cover	1
4	30.9814-603-2	Kryt / Abdeckung / Cover	1
5	30.9814-603-3	Kryt / Abdeckung / Cover	1
6	30.9814-603-B1	Uhelník / Winkeleisen / Angle Bar	1
7	30.9814-603-B2	Plech / Blech / Sheet Metal	2

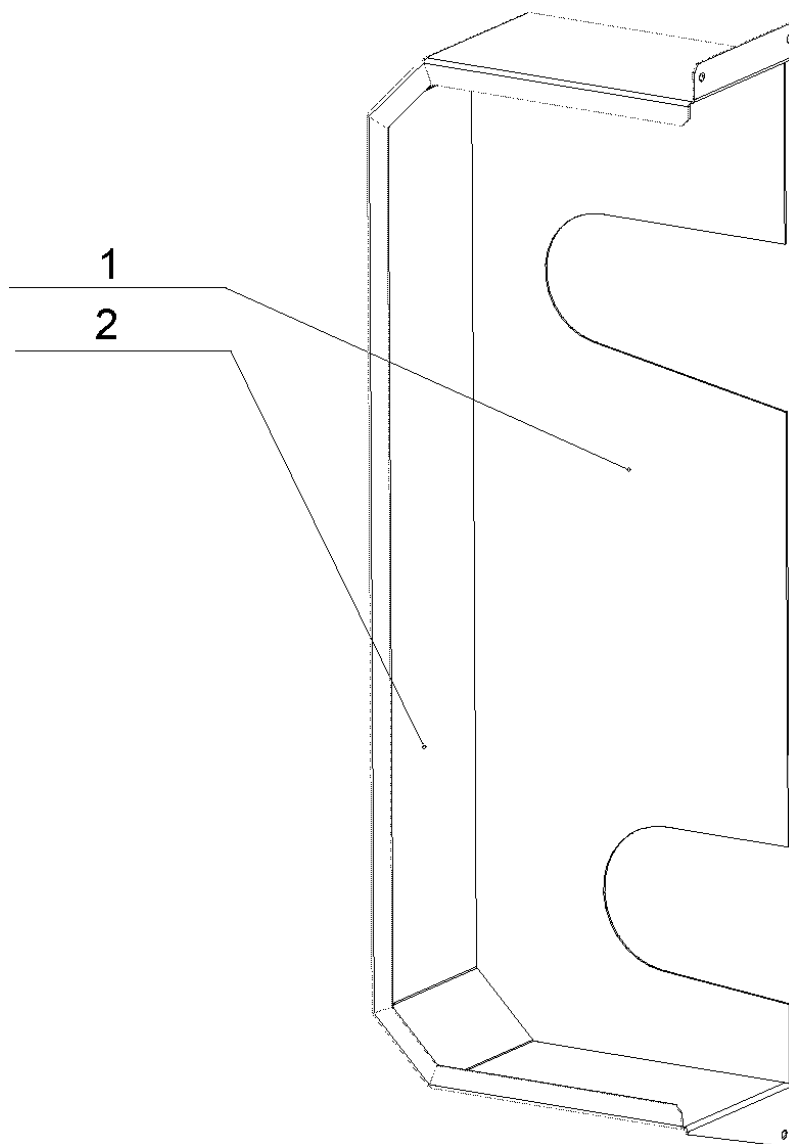
**24.14. Kryt variátoru / Variatordeckel / Variator cover**

Poz.	Objednací číslo	Název položky	ks
Pos.	Bestell - Nr.	Bezeichnung	Menge
Pos.	Reference No.	Item	Pcs.
1	30.8914-609-2	Kryt variátoru / Variatordeckel / Variator cover 1.5x245x708	1
2	30.8914-209-2	Kryt variátoru / Variatordeckel / Variator cover 1.5x146x1223	1