

Series **Ergonomic**



Ergonomic 320.250 G

Operating instructions

**Before transporting and using the machine,
please read the instructions thoroughly!**

Seriové číslo / Serien Nummer / Serial Number _____

Service and information

Your BOMAR dealer:

Direct BOMAR contact:

BOMAR spol. s r.o.
Těžební 1236/1
62700 Brno
Czech Republic, EU

telefon: +420 – 533 426 100
fax: +420 – 533 426 109
e-mail: info@bomar.cz
www: <http://www.bomar.cz>

We are available:

Mondays to Fridays

7⁰⁰ – 16⁰⁰

Version:

1.05 / Mar. 2010
rev. 1

BOMAR, spol. s r.o. © – Subject to modifications and amendments.

Content

1. SAFETY NOTES	7
1.1. Machine determination.....	8
1.2. Protective suit and personal safety.....	8
1.3. Safety notes for machine operator.....	9
1.4. Safety notes for the servicing and repairs.....	9
1.5. Safety machine accessories.....	10
1.5.1. Total Stop.....	10
1.5.2. Arm cover.....	10
1.5.3. Band saw cover.....	10
1.5.4. Saw band stretching and rupture inspection.....	10
1.6. Safety notes for the cooling.....	11
1.6.1. Instructions for first help.....	11
1.7. Umístění štítku stroje / Maschinenschild position / Position of machine label.....	11
1.8. Umístění bezpečnostních značek / Verteilung der Sicherheitszeichen / Position of safety symbols.....	12
2. MACHINE DOCUMENTATION	13
2.1. Technická data / Technische Daten / Technical data.....	14
2.2. Rozměrové schéma / Aufstellzeichnung / Installation diagram.....	15
2.3. Popis / Beschreibung / Description.....	16
2.4. Transportation and stocking.....	17
2.4.1. Conditions for transportation and stocking.....	17
2.4.2. Transport and stocking preparations.....	17
2.4.3. Transport and stocking.....	17
2.4.4. Transportní schéma / Transport schema / Transport scheme.....	18
2.5. Activation.....	19
2.5.1. Machine working conditions.....	19
2.6. Band saw unpacking and assembling.....	19
2.6.1. Machine installing and levelling.....	21
2.6.2. Machine disposal after lifetime.....	21
2.6.3. Kotevní plán / Verankerungsplan / Grounding plan.....	22
2.7. Electrical connection.....	23
2.7.1. Check the direction of the saw band.....	23
2.8. Filling of the cooling system.....	23
2.9. Check machine function.....	24
2.10. Saw band.....	24
2.10.1. Saw band size.....	24
2.10.2. Selection of the saw band tooth system.....	24
2.10.3. Saw band running-in.....	24
2.10.4. Tables for teeth selection.....	25
3. MACHINE CONTROL.....	27
3.1. Control elements.....	28
3.1.1. Ergonomic 320.250 G without frequency converter.....	28
3.1.2. Ergonomic 320.250 G with frequency converter.....	29
3.2. Machine control.....	30
3.2.1. Cutting.....	30
3.2.2. Setting of the material length.....	30
3.2.3. Cutting speed adjustment.....	31
3.2.4. Angular cut setting.....	31
3.2.5. Optimal adjusting of the guide cubes span.....	31
3.2.6. Brush adjustment.....	32
3.3. Material insertion.....	32
3.3.1. Handling agent selection.....	32
3.3.2. Insertion.....	33
3.3.3. Bundle material cutting.....	33
4. MACHINE SERVICE	35
4.1. Saw band dismantling.....	36
4.2. Saw band installation.....	37
4.3. Saw band stretching and inspection.....	38
4.3.1. Saw band stretching.....	38
4.3.2. Saw band inspection.....	38
4.4. Cooling agents and chips disposal.....	39
4.4.1. Coolant device inspection.....	39
4.4.2. Chips disposal.....	40
4.5. Greases and oils.....	40
4.5.1. Gearbox oils.....	40
4.5.2. Lubricant greases.....	40

4.5.3.	Lubrication.....	41
4.5.4.	Hydraulic oils.....	41
4.5.5.	Hydraulic unit service.....	42
4.6.	Machine cleaning.....	43
4.7.	Worn pieces replacement.....	43
4.7.1.	Hard metal guides replacement.....	43
4.7.2.	Saw band guiding rollers replacement.....	44
4.7.3.	Round brush replacement.....	45
4.7.4.	Stretching wheel replacement.....	46
4.7.5.	Driving wheel replacement.....	48
4.7.6.	Cooling pump replacement.....	49

5. ZÁVADY / TROUBLESHOOTING51

5.1.	Mechanical problems.....	52
5.2.	Electric problems.....	54
5.3.	Hydraulic problems.....	55

6. SCHÉMATA / SCHEMAS / SCHEMATICS57

6.1.	Elektrická schémata / Elektroschemas / Wiring diagrams – bez frekv. měniče / ohne Frequenzumrichter / without frequency convertor – 3×400 V/50 Hz, TN-C-S.....	58
6.2.	Elektrické schéma / Elektroschema / Wiring diagrams – Erg. 320.250 G-F/DG-F/DGS-F, 3×400 V TN-C-S.....	62
6.3.	Elektrické schéma / Elektroschema / Wiring diagrams – Erg. 320.250 G-F/DG-F/DGS-F, 3×400V TN-C.....	66
6.4.	Elektrické schéma / Elektroschema / Wiring diagrams – Erg. 320.250 G-F/DG-F/DGS-F, 3×230 V.....	71
6.5.	Hydraulické schéma Hydraulisches Schéma Hydraulic diagram.....	76

7. VÝKRESY SESTAV PRO OBJEDNÁNÍ NÁHRADNÍCH DÍLŮ / ZEICHNUNGEN FÜR BESTELLUNG DER ERSATZTEILE / DRAWING ASSEMBLIES FOR SPARE PARTS ORDER77

7.1.	Ergonomic 320.250 G.....	78
7.2.	Kusovník / Stückliste / Piece list – Ergonomic 320.250 G.....	79
7.3.	Ergonomic 320.250 G.....	80
7.4.	Kusovník / Stückliste / Piece list – Ergonomic 320.250 G.....	81
7.5.	Rameno / Sägerahmen / Saw arm.....	82
7.6.	Kusovník / Stückliste / Piece list – Rameno / Sägerahmen / Saw arm.....	83
7.7.	Rameno / Sägerahmen / Saw arm.....	84
7.8.	Kusovník / Stückliste / Piece list – Rameno / Sägerahmen / Saw arm.....	85
7.9.	Konzola / Konzole / Console.....	86
7.10.	Kusovník / Stückliste / Piece list – Konzola / Konzole / Console.....	87
7.11.	Svěrák / Schraubstock / Vice.....	88
7.12.	Kusovník / Stückliste / Piece list – Svěrák / Schraubstock / Vice.....	89
7.13.	Válec zvedací / Hebezyylinder / Liftink cylinder.....	90
7.14.	Kusovník / Stückliste / Piece list – Válec zvedací / Hebezyylinder / Liftink cylinder.....	91
7.15.	Podstavec / Untersatz / Base.....	92
7.16.	Kusovník / Stückliste / Piece list – Podstavec / Untersatz / Base.....	93
7.17.	Ovládací panel / Bedienpult / Control panel.....	94
7.18.	Kusovník / Stückliste / Piece list – Ovládací panel / Bedienpult / Control panel.....	95
7.19.	Chlazení / Kühlung / Cooling.....	96
7.20.	Kusovník / Stückliste / Piece list – Chlazení / Kühlung / Cooling.....	97
7.21.	Napínání / Spannung / Tensioning.....	98
7.22.	Kusovník / Stückliste / Piece list – Napínání / Spannung / Tensioning.....	99
7.23.	Vedení pásu / Sägebandführung / Belt guide.....	100
7.24.	Kusovník / Stückliste / Piece list – Vedení pásu / Sägebandführung / Belt guide.....	101
7.25.	Vodící kostka / Führungsklotz / Guiding cube – 1.....	102
7.26.	Kusovník / Stückliste / Piece list – Vodící kostka / Führungsklotz / Guiding cube – 1.....	103
7.27.	Vodící kostka / Führungsklotz / Guiding cube – 2.....	104
7.28.	Kusovník / Stückliste / Piece list – Vodící kostka / Führungsklotz / Guiding cube – 2.....	105
7.29.	Kartáč / Bürste / Brush.....	106
7.30.	Pružina / Feder / Spring.....	107

6. **Schémata / Schemas / Schematics**

6.1. Elektrická schémata / Elektroschemas / Wiring diagrams –
bez frekv. měniče / ohne Frequenzumrichter / without
frequency convertor – 3×400 V/50 Hz, TN-C-S

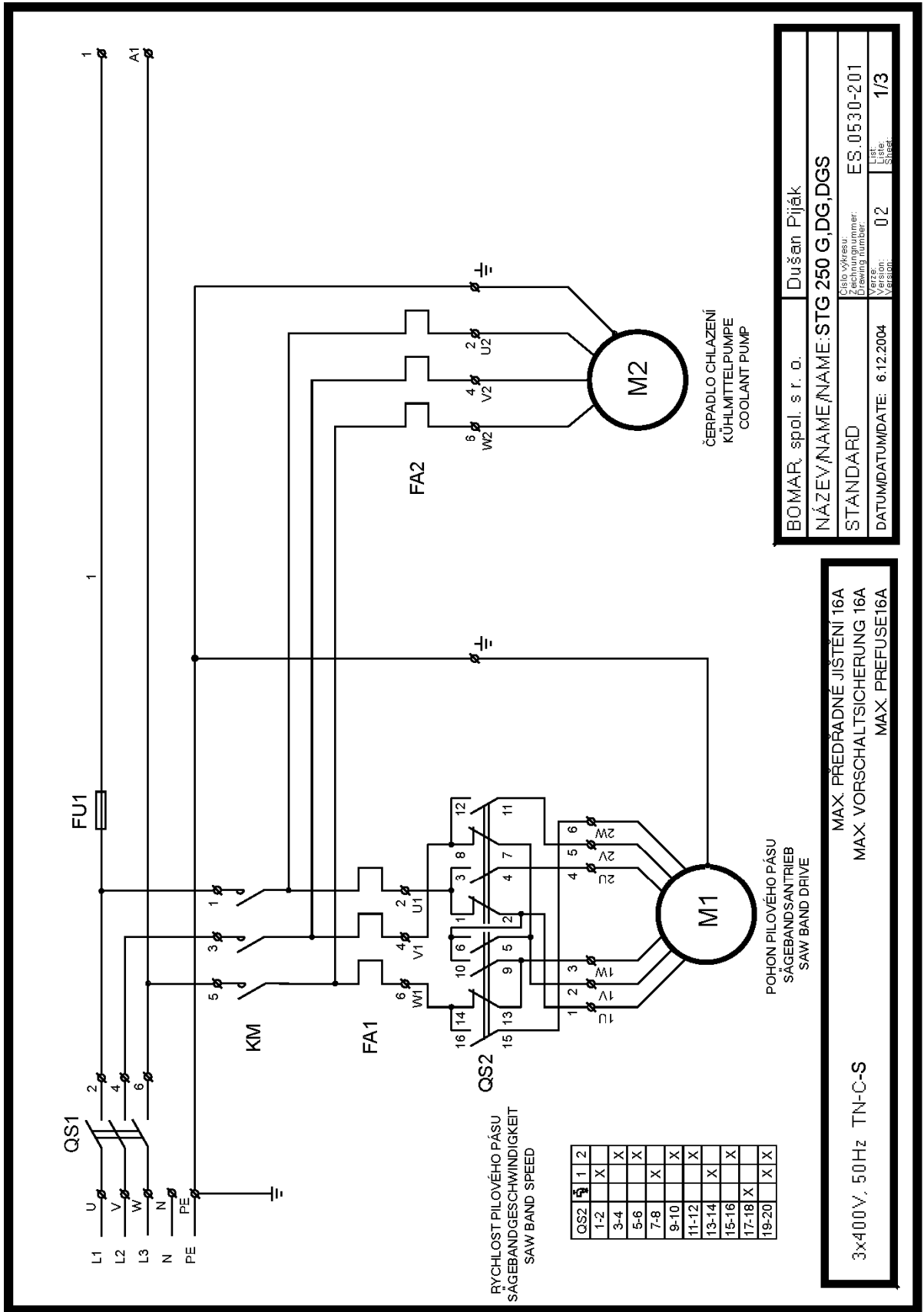

BOMAR, spol. s r. o.	Dušan Píják
NÁZEV/NAME/NAME: STG 250 G,DG,DGS	
STANDARD	Číslo výkresu: Zeichnungsnummer: ES.0530-201
DATUM/DATUM/DATE: 6.12.2004	Verze: Version: 02
	Listo: Sheet: 1/3

3×400V, 50Hz TN-C-S	MAX. PŘEDŘADNÉ JIŠTĚNÍ 16A MAX. VORSCHALTSICHERUNG 16A MAX. PREFUSE 16A
---------------------	---

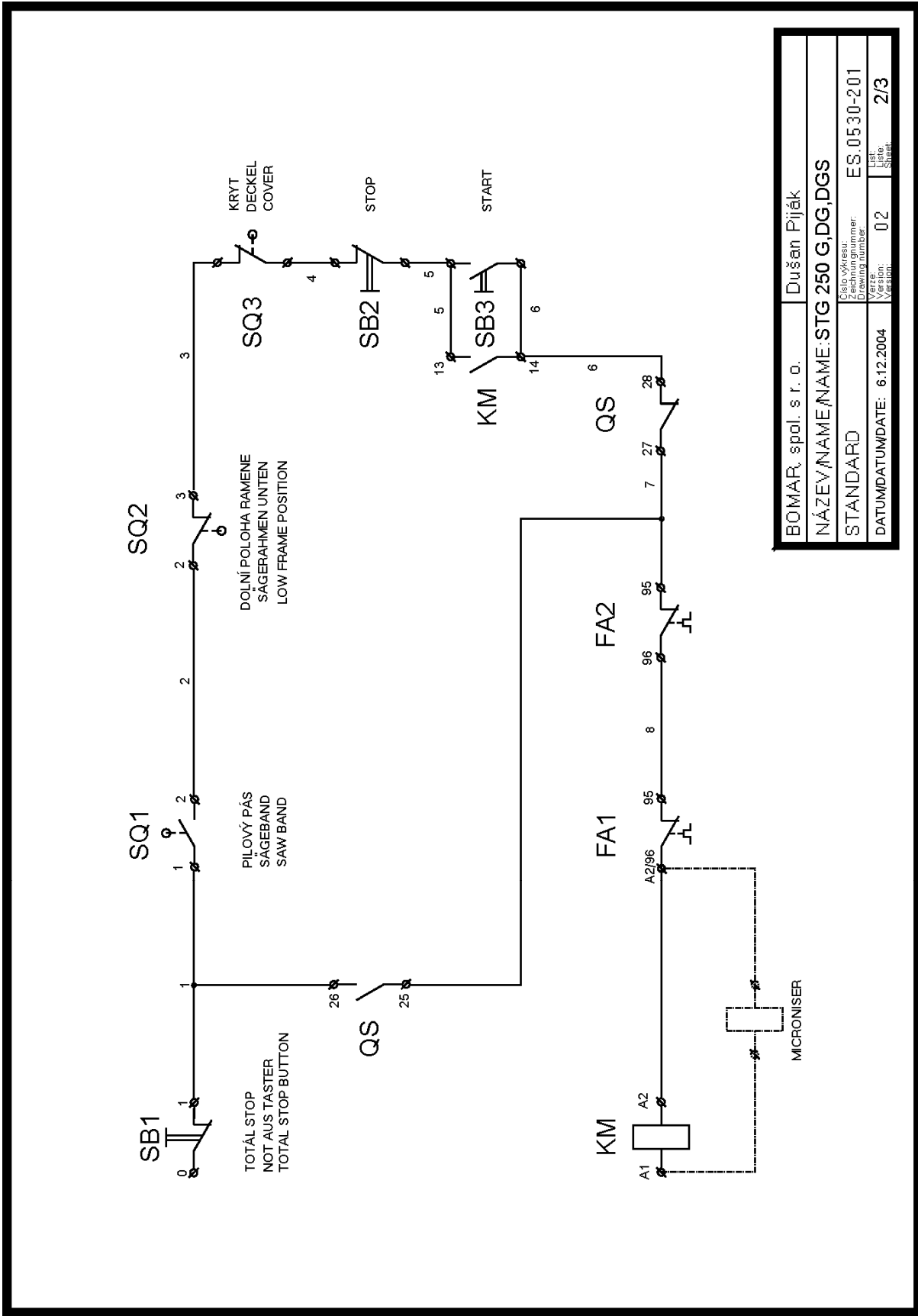

BOMAR, spol. s r. o.	Dušan Píják
NÁZEV/NAME/NAME: STG 250 G, DG, DGS	
STANDARD	Celo výkres: Drawing number: ES_0530-201
DATUM/DATE: 6.12.2004	Verze: Version: 02
	Strana: Sheet: 2/3

PŘÍSTROJOVÁ DESKA
GERÄTEBRETT
DASHBOARD

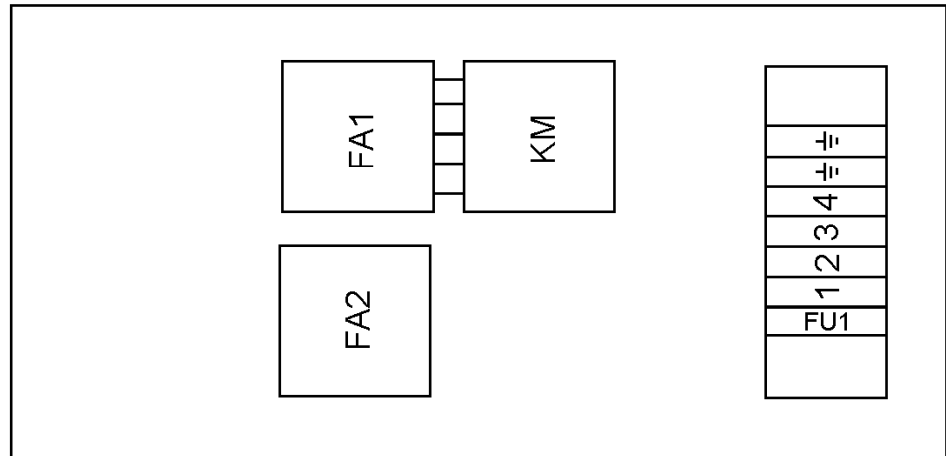

OVLÁDACÍ PANEL
BEDIENPULT
CONTROL PANEL

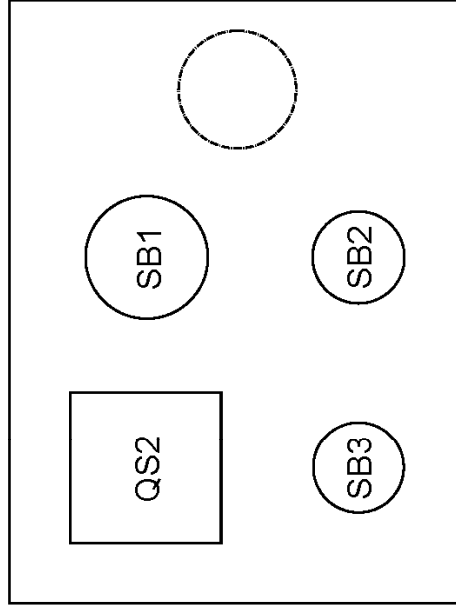

BOMAR s.r.o.	KRESLIL: Dušan Piják
NÁZEV: SCHEMA STG 250 G,DG,DGS	
STANDARD	REV. STG 250
DATUM: 1.1.2001	VÝTISK: List: 3/3

Objednáací číslo	Název položky		Ozn.	ks
Bestell - Nr.	Bezeichnung		Signatur	Menge
Reference No.	Item		Sign.	Pcs.
91.001.007	Elektromotor / Elektromotor / Electromotor	TM902/4 B5	M1	1
91.020.006	Čerpadlo chlazení / Kühlmittelpumpe / Coolant pump	3COA2-22H	M2	1
91.040.001	Stykač / Schaltschütz / Contactor	9A 230V	KM	1
91.050.003	Relé tepelné / Electro thermal relay / Thermorelais	0.26-0.43A	FA2	1
91.050.009	Relé tepelné / Electro thermal relay / Thermorelais	3.0-4.7A	FA1	1
91.060.012	Hlavice TOTAL STOP / NOT-AUS Taste / Total stop jugulum	ZB5AS844	SB1	1
91.061.006	Kontakt rozp.+adapt. / Schaltkontakt / Expand.+adapt. contact	ZB5AZ102	SB1	1
91.060.015	Hlavice rudá / Kopf – rot / Red jugulum	ZB5AA4	SB2	1
91.061.006	Kontakt rozp.+adapt. / Schaltkontakt / Expand.+adapt. contact	ZB5AZ102	SB2	1
91.060.014	Hlavice zelená / Kopf – grün / Green jugulum	ZB5AA3	SB3	1
91.061.007	Kontakt spín.+adapt. / Schaltkontakt / Switch.+adapt. contact	ZB5AZ101	SB3	1
91.170.003	Spínač vačkový / Schalter / Cam switch	194L-E16-1753	QS1	1
91.180.001	Deska spínače černá / Schalterplatte – schwarz / Black board of the switch	194L-HE4E-175	QS1	1
91.171.006	Spínač vačkový / Schalter / Cam switch	S10-60129	QS2	1
91.173.012	Spínač konc.-zámek / Endschalter / Limit switch-lock	QKS8	SQ3	1
91.173.007	Spínač koncový / Endschalter / Limit switch	Pizzato	SQ1,2	2
91.230.001	Pojistka / Sicherung / Fuse	2A	FU1	1
91.190.004	Krabice elektro / Buchse / Box			1

6.2. Elektrické schéma /
Elektroschema /
Wiring diagrams – Erg. 320.250 G-F/DG-F/DGS-F, 3×400 V TN-C-S

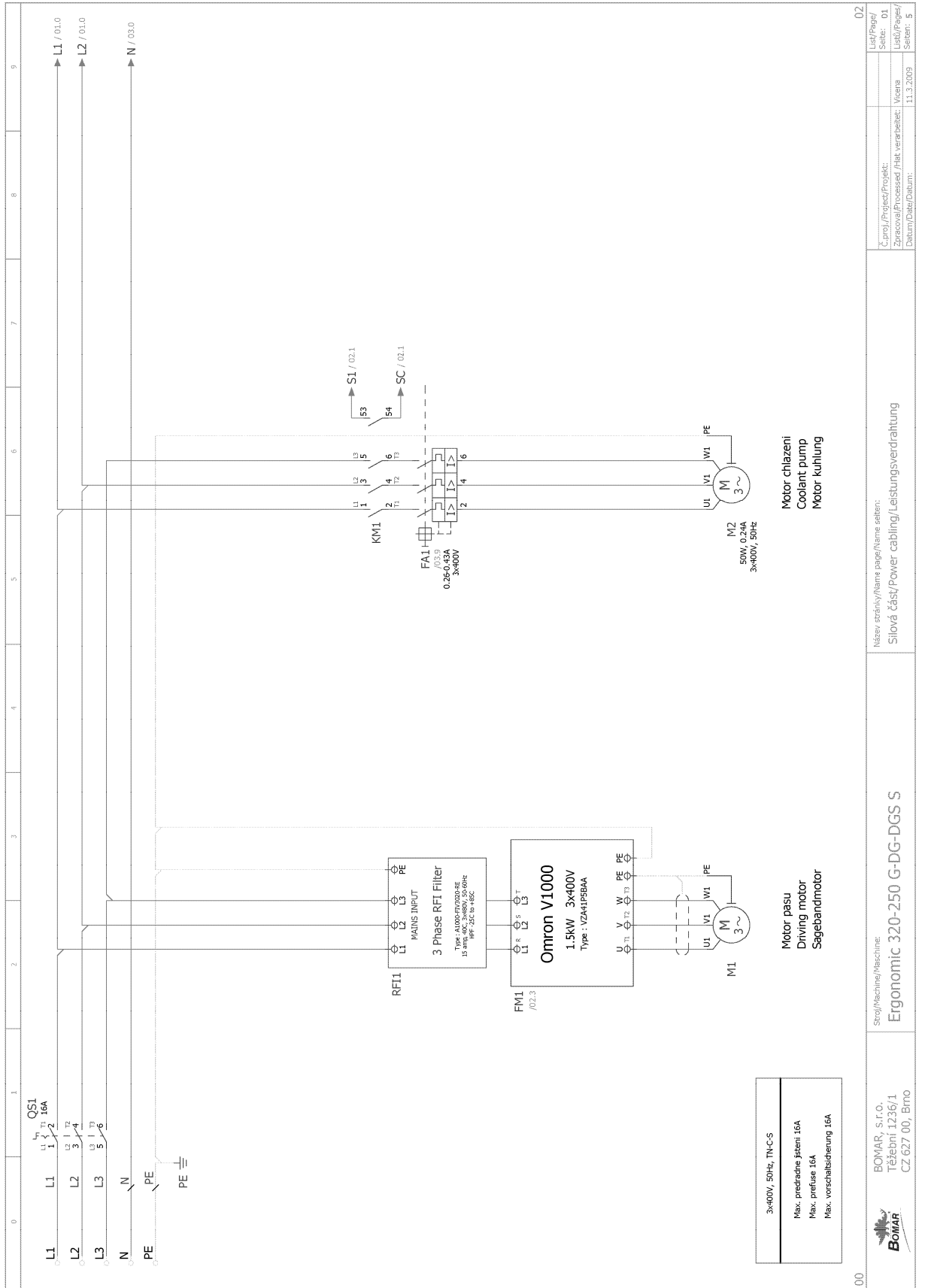

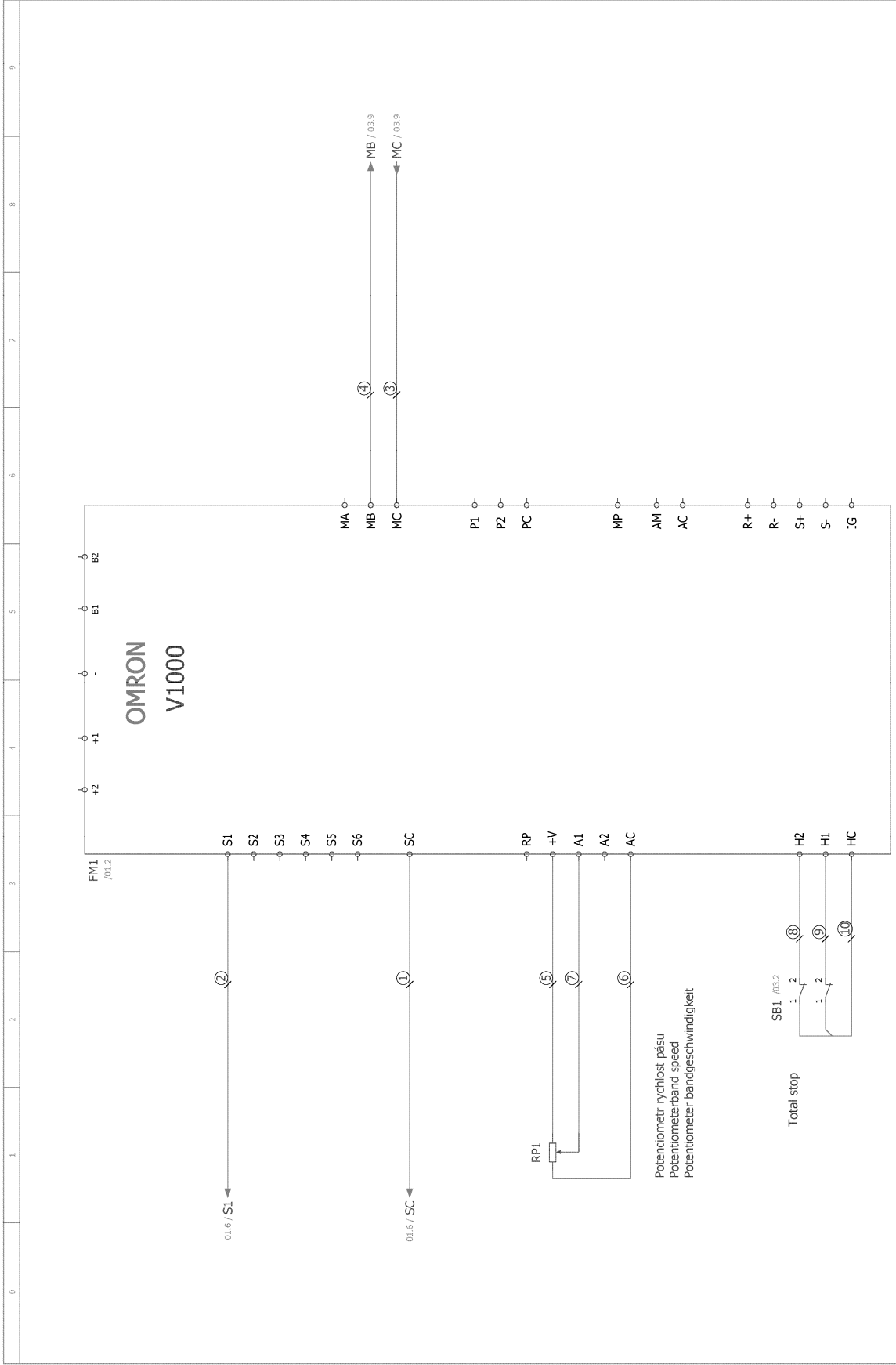

01	02	03	04	05	06	07	08	09
Název stránky/Name page/Name seiten: Frekvenční měnič/Speed controller/Frequenzumrichter			C:\proj\Projekt\Projekt: Zpracovatel/Processed /Hat verarbeitet: Datum/Date/Datum:			List/Page/ Seide: List/Page/ Seiten:		
Stroj/Machine/Maschine: Ergonomic 320-250 G-DG-DGS S			BOMAR, s.r.o. Těšební 1236/1 CZ 627 00, Brno			12.3.2009 Věcna		

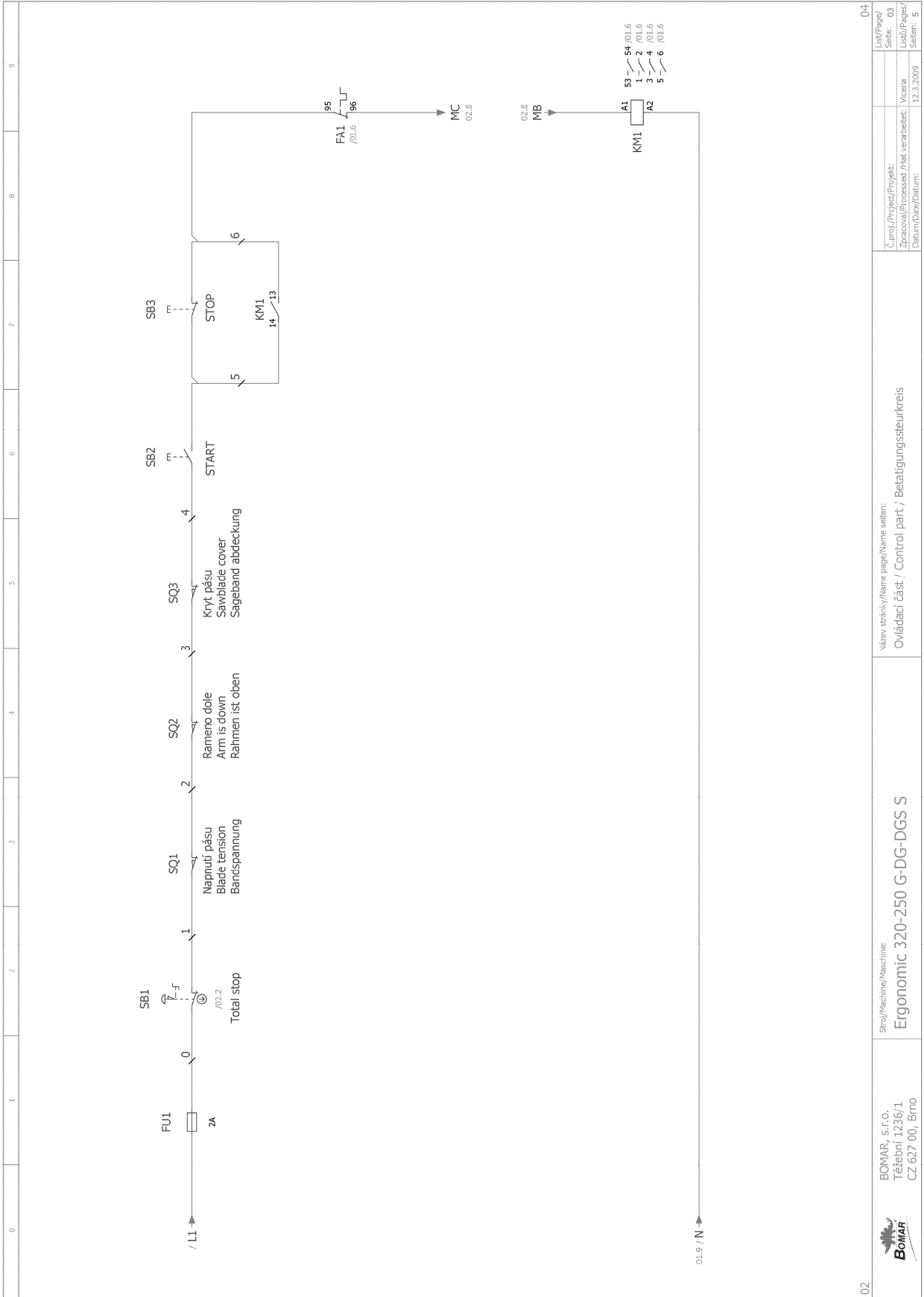

02	Stroj/Machine/Maschine: Ergonomic 320-250 G-DG-DGS S	Název stránky/Name page/Name sheet: Ovládací část / Control part / Betätigungssteuerkreis	Č.proj./Projek/Projekt: Zpracováno/Processed /Hat. verarbeitet: Datum/Date/Datum:	03 03 12.3.2009	04 03 5
----	--	--	---	-----------------------	---------------

0	1	2	3	4	5	6	7	8	9
Kusovník artiklů									
Označení přístroje	Typ přístroje			Objednací číslo	Výrobce	Skladové číslo	Množství	Umístění (strana, sloupec)	
-FA1	Tepečná ochrana 0,26 - 0,43A			MT03C	GE	91.050.003	1	/01.6	
-FM1	Frekvenční měnič 1,5KW			VZ41P5BAA	OMRON	91.012.026	1	/02.3	
-FU1	Pojistkové pouzdro			WK47HS5...U	WIELAND	91.251.102	1	/03.1	
-FU1	Pojistka trubičková 2A, 5x20			FZA/250V	ESKA	91.230.001	1	/03.1	
-KM1	Pomocný kontakt ke stykači			MARN42ZAT	GE	91.041.005	1	/01.6	
-KM1	Stykač 230V AC, 9A			MC1A 10E	GE	91.040.001	1	/03.9	
-M1	Motor Pěsu			TM 90 2S B5		91.001.027	1	/01.2	
-M2	Čerpadlo 50W, 0,24A 3x400V, 50Hz			2COP1-22 HP1		91.020.006	1	/01.6	
-Q51	Hlavní vypínač 16A			P016	GIOVENZANA	91.170.003	1	/01.1	
-Q51	Hlavní vypínač ovládání			SE 16	GIOVENZANA	91.180.001	1	/01.1	
-RF11	Filter k frekvenčnímu měniči 1,5KW			A1000-FIV3010-RE	OMRON	91.012.027	1	/01.2	
-RP1	Potenciometr 4K7			TP195 4K7-N20A	TES-Ostrava	91.283.002	1	/02.1	
-RP1	Svorka rychloupínací			Svorka rychloupínací	WIELAND	91.250.009	3	/02.1	
-SB1	Hlavice hříbového ovládače			ZB5 AS844	TELEMECANIQUE	91.060.012	1	/03.2	
-SB1	Rozpínací kontakt s adaptérem			ZB5AZ102	TELEMECANIQUE	91.061.006	1	/03.2	
-SB1	Rozpínací kontakt			ZBE-102	TELEMECANIQUE	91.061.008	2	/02.2	
-SB2	Hlavice zelená			ZB5AA3	TELEMECANIQUE	91.060.014	1	/03.6	
-SB2	Kontakt s adaptérem spínací			ZB5AZ101	TELEMECANIQUE	91.061.007	1	/03.6	
-SB3	Hlavice červená			ZB5AA4	TELEMECANIQUE	91.060.015	1	/03.7	
-SB3	Rozpínací kontakt s adaptérem			ZB5AZ102	TELEMECANIQUE	91.061.006	1	/03.7	
-SQ1	Koncový spínač			D4N-4A31	OMRON	91.173.007	1	/03.3	
-SQ2	Koncový spínač			D4N-4A31	OMRON	91.173.007	1	/03.4	
-SQ3	Bezpečnostní koncový spínač			QKS8	KEDU	91.173.012	1	/03.5	

Výrobce si vyhrazuje použít ekvivalentní náhrady přístrojů.

03
Datum

Ergonomic 320-230 G-DG-DGS\$ Bomar s.r.o.

Lib: 04
Lib: 5

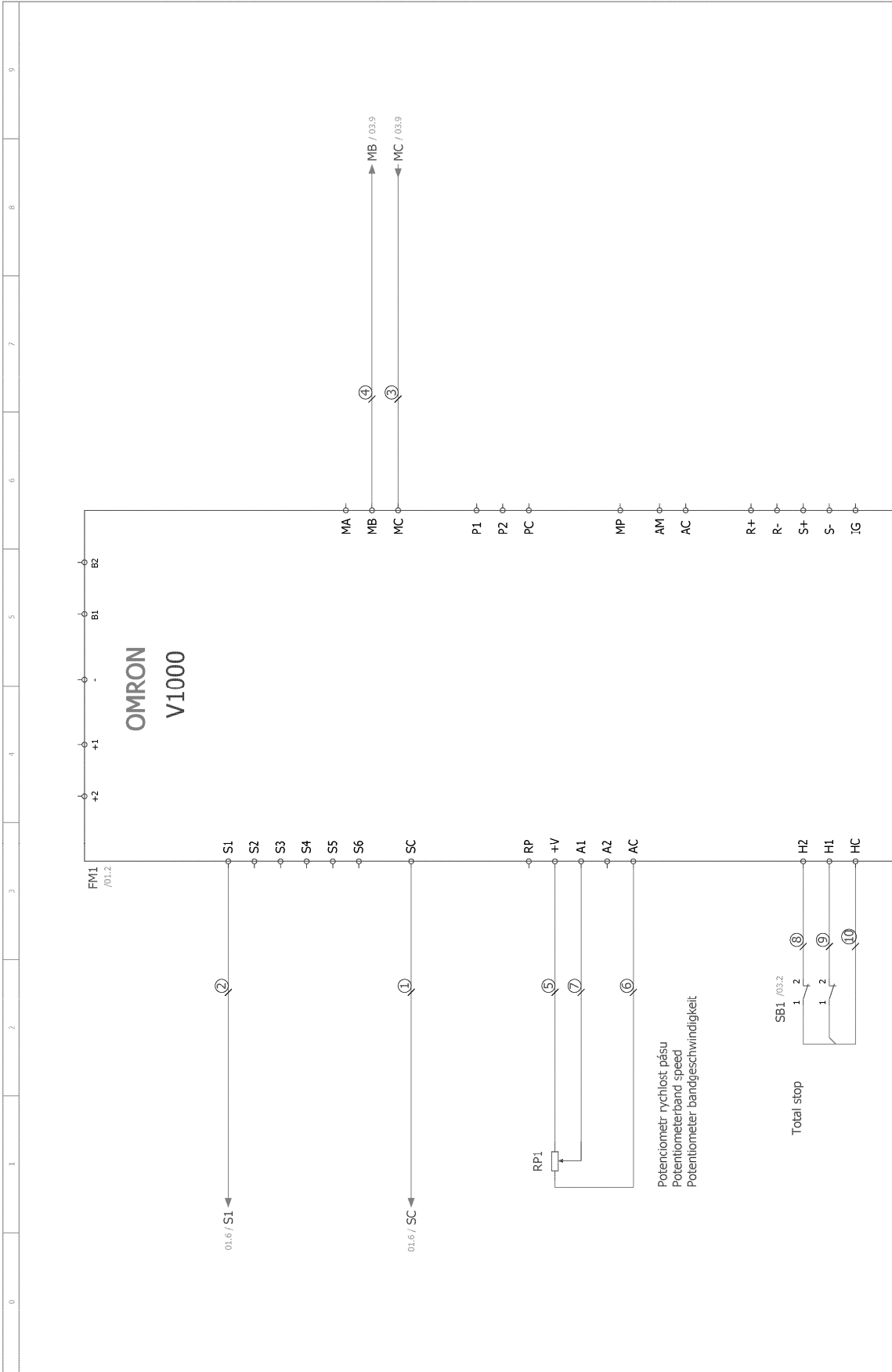

01	Stroj/Machine/Maschine: Ergonomic 320-250 G-DG-DGS P	Název stránky/Name page/Name sheet: Frekvenční měnič/Speed controller/Frequenzumrichter	03
	BOMAR, s.r.o. Těšební 1236/1 CZ 627 00, Brno	Z. proj./Project/Projekt: Zpracoval/Processed /Hat. verarbeitete: Vlcina Datum/Dat./Datum: 12.3.2009	Lib./Page/ Seit.: 02 Lib./Page/ Seiten: 6

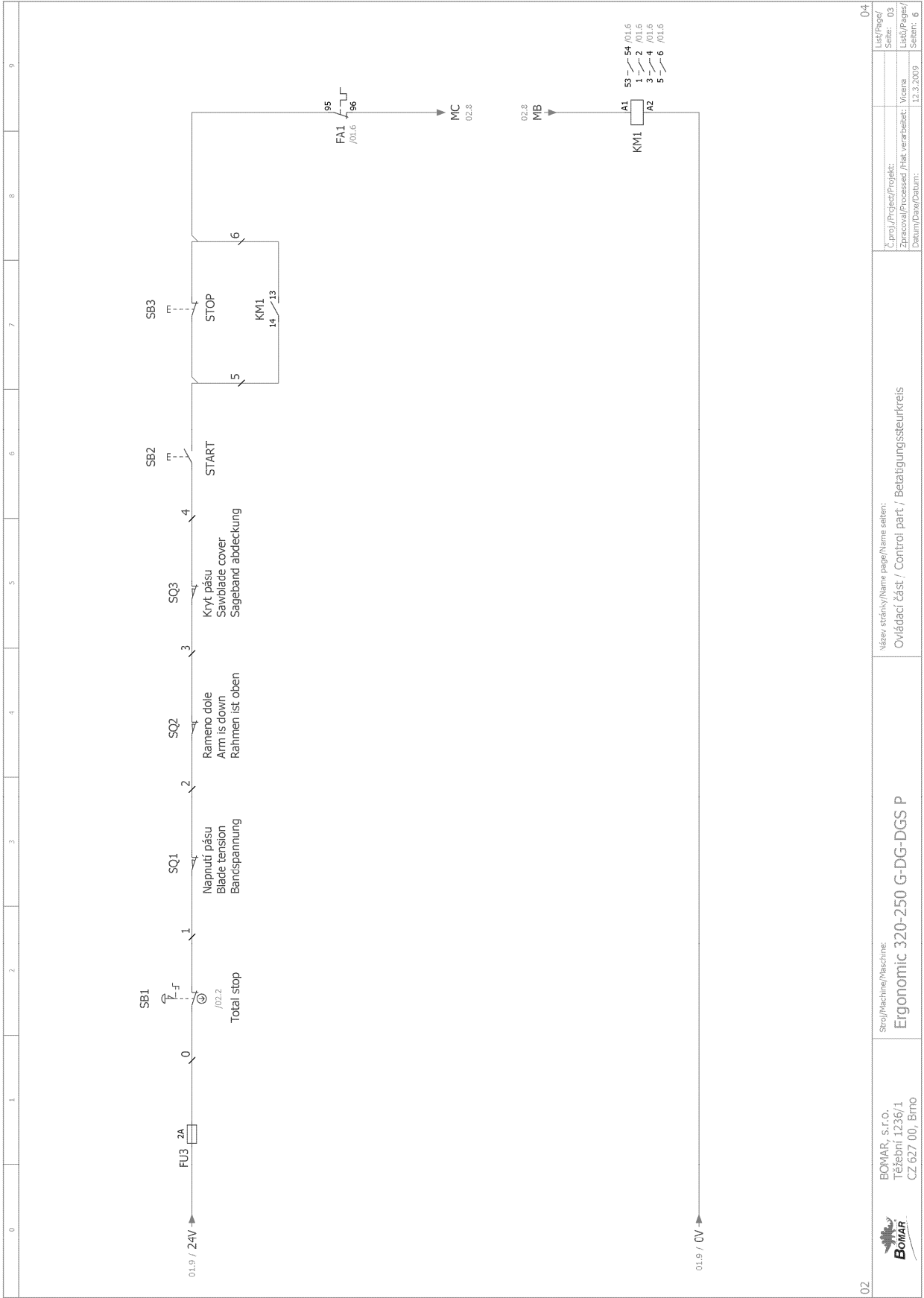

04	03	03	03
Lib/Page/	Seit/	Lib/Page/	Seit/
Zpracováno/Processed/	Wicena/	Zpracováno/Processed/	Wicena/
Datum/Date/	Datum/	Datum/Date/	Datum/
12.3.2009	12.3.2009	12.3.2009	12.3.2009
Název stránky/Name page/Name seiten:		Ovládací část / Control part / Betätigungssteuerkreis	
Stroj/Machine/Maschine:		Ergonomic 320-250 G-DG-DGS P	
BOMAR, s.r.o.		Těšební 1236/1	
CZ 627 00, Brno			

0	1	2	3	4	5	6	7	8	9
Kusovník artiklů									
Označení přístroje	Typ přístroje		Objednávací číslo	Výrobce	Skladové číslo	Množství	Umístění (strana, sloupec)		
-FA1	Teplotní ochrana 0,26 - 0,43A		MT03C	GE	91.050.003	1	/01.6		
-FM1	Frekvenční měnič 1,5kW		VZ441P5BAA	OMRON	91.012.026	1	/02.3		
-FU1	Pojistkové pouzdro		WK4/THS5...U	WIELAND	91.251.102	1	/01.7		
-FU1	Pojistka trubičková 2A, 5x20		F2A/250V	ESKA	91.230.001	1	/01.7		
-FU2	Pojistkové pouzdro		WK4/THS5...U	WIELAND	91.251.102	1	/01.7		
-FU2	Pojistka trubičková 2A, 5x20		F2A/250V	ESKA	91.230.001	1	/01.7		
-FU3	Pojistkové pouzdro		WK4/THS5...U	WIELAND	91.251.102	1	/03.1		
-FU3	Pojistka trubičková 2A, 5x20		F2A/250V	ESKA	91.230.001	1	/03.1		
-KM1	Pomocný kontakt ke stykači		MARN422AT	GE	91.041.005	1	/01.6		
-KM1	Stykač 230V AC, 9A		MCJA 10E	GE	91.040.001	1	/03.9		
-M1	Motor Pésu		TM 90 2S B5		91.001.027	1	/01.2		
-M2	Čerpadlo 50W, 0,24A 3x400V, 50Hz		2C0P1-22 HP1		91.020.006	1	/01.6		
-QS1	Hlavní vypínač 16A		P016	GIOVENZANA	91.170.003	1	/01.1		
-QS1	Hlavní vypínač-ovládání		SE 16	GIOVENZANA	91.180.001	1	/01.1		
-RF11	Filtr k frekvenčnímu měnič 1,5kW		A1000-FIV3010-RE	OMRON	91.012.027	1	/01.2		
-RP1	Potenciometr 4k7		TP195 4k7-N20A	TES-Ostrava	91.283.002	1	/02.1		
-RP1	Svorka rychloupínač		Svorka rychloupínač	WIELAND	91.250.009	3	/02.1		
-SB1	Hlavice hříbového ovládače		ZB5 A5844	TELEMECANIQUE	91.060.012	1	/03.2		
-SB1	Rozpínač kontakt s adaptérem		ZB5AZ102	TELEMECANIQUE	91.061.006	1	/03.2		
-SB1	Rozpínací kontakt		ZBE-102	TELEMECANIQUE	91.061.008	2	/02.2		
-SB2	Hlavice zelená		ZB5AA3	TELEMECANIQUE	91.060.014	1	/03.6		
-SB2	Kontakt s adaptérem spínací		ZB5AZ101	TELEMECANIQUE	91.061.007	1	/03.6		
-SB3	Hlavice červená		ZB5AA4	TELEMECANIQUE	91.060.015	1	/03.7		
-SB3	Rozpínací kontakt s adaptérem		ZB5AZ102	TELEMECANIQUE	91.061.006	1	/03.7		
-SQ1	Koncový spínač		D4N-4A31	OMRON	91.173.007	1	/03.3		
-SQ2	Koncový spínač		D4N-4A31	OMRON	91.173.007	1	/03.4		
-SQ3	Bezpečnostní koncový spínač		QK58	KEDU	91.173.012	1	/03.5		

Výrobce si vyhrazuje použít ekvivalentní náhrady přístrojů.

04.2

03

Datum

Ergonomic 320-230 G-DG-DGS

Bomar s.r.o.

Lib. 04
Lib. 6

0	1	2	3	4	5	6	7	8	9
Kusovník artiklů									
Označení přístroje	Typ přístroje			Objednací číslo	Výrobce	Skladové číslo	Množství	Umístění (strana, sloupec)	
-T11	Transformátor 400V/230V/24V 20VA			JBC E2025 - 0173	ELEKTROKOV a.s. ZNOJMO	91.C80.003	1	/01.8	
<p>Výrobce si vyhrazuje použít ekvivalentní náhrady přístrojů.</p>									
04 Datum									Lib: 04.a List: 6

6.4. Elektrické schéma / Elektroschema / Wiring diagrams – Erg. 320.250 G-F/DG-F/DGS-F, 3×230 V

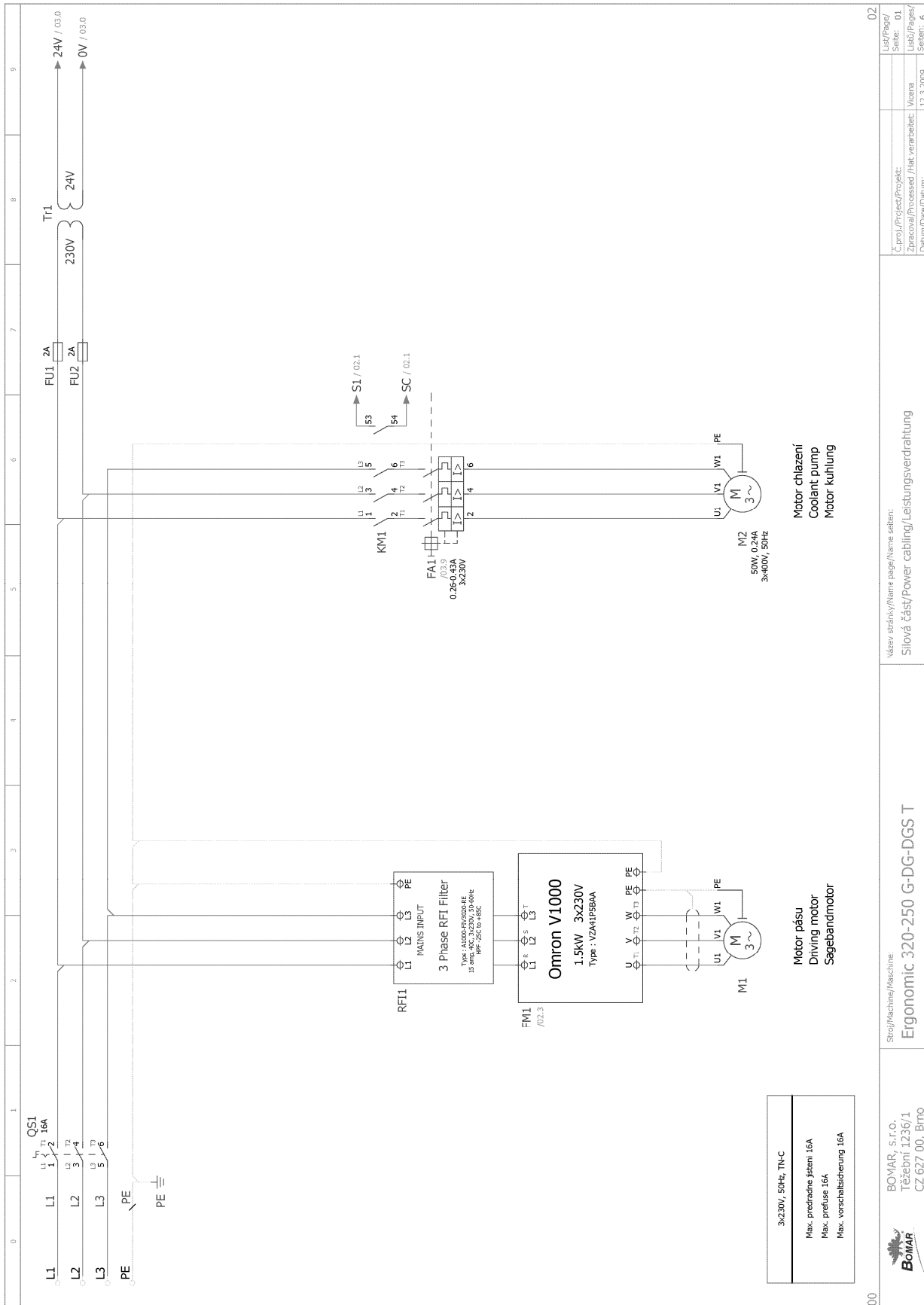

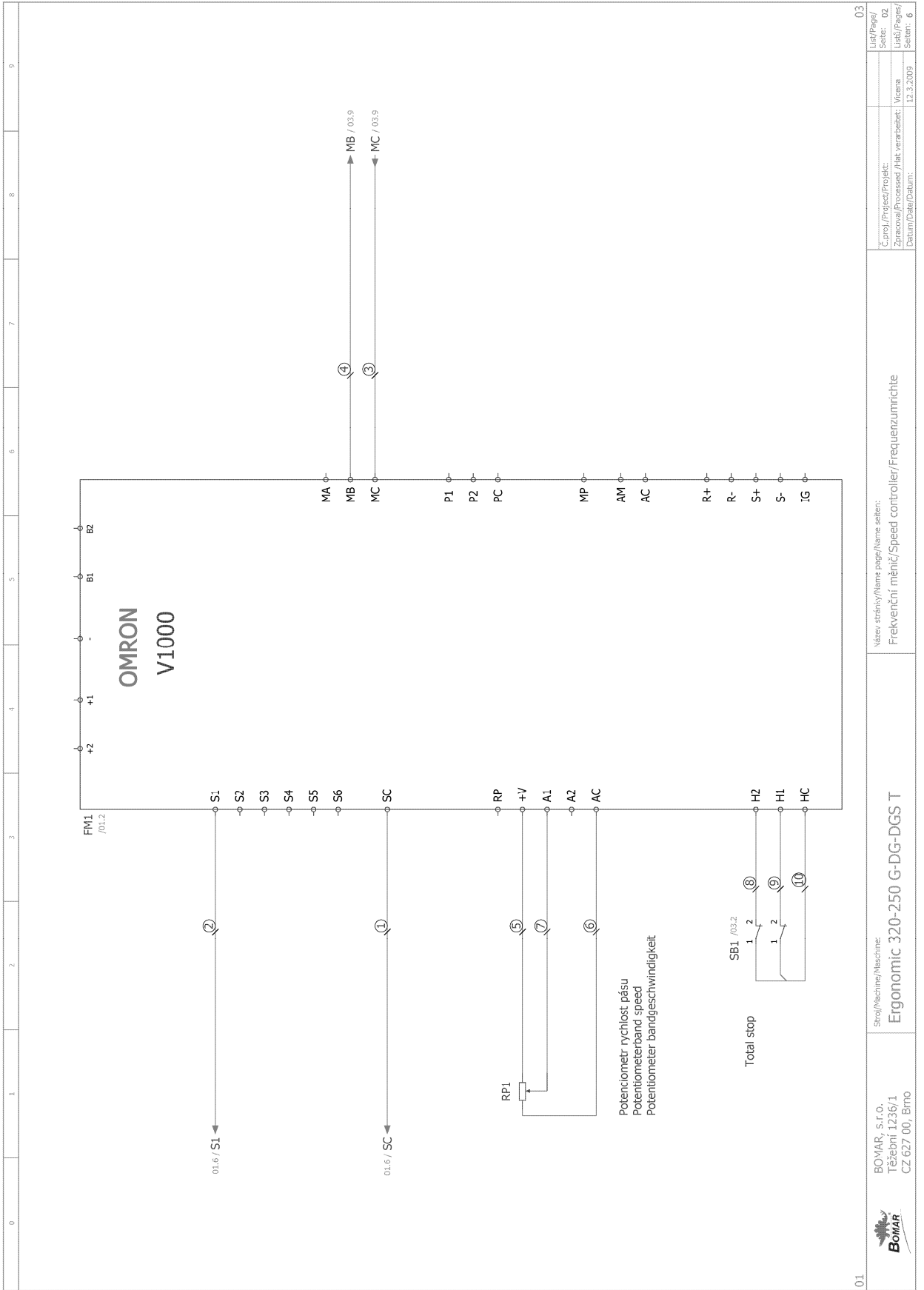

01	BOMAR, s.r.o. Těšební 1236/1 CZ 627 00, Brno	Stroj/Machine/Maschine: Ergonomic 320-250 G-DG-DGS T	Název stránky/Name page/Name sheet: Frekvenční měnič/Speed controller/Frequenzumrichter	Č.j./Project/Projekt: Zpracoval/Processed /Hat. verarbeitet: Datum/Date/Datum: 12.3.2009	03 List/Page/ Seite: 02 Určilo/Pages/ Seite: 6
----	--	---	--	---	--

Kusovník artiklů

Označení přístroje	Typ přístroje	Objednávací číslo	Výrobce	Skladové číslo	Množství	Umístění (strana, sloupec)
-FA1	Teplotní ochrana 0,26 - 0,43A	MT03C	GE	91.050.003	1	/01.6
-FW1	Frekvenční měnič 1,5kW	VZA41P5BAA	OMRON	91.012.026	1	/02.3
-FU1	Pojistkové pouzdro	WK4/THS15...U	WIELAND	91.251.102	1	/01.7
-FU1	Pojistka trubičková 2A, 5x20	F2A/250V	ESKA	91.230.001	1	/01.7
-FU2	Pojistkové pouzdro	WK4/THS15...U	WIELAND	91.251.102	1	/01.7
-FU2	Pojistka trubičková 2A, 5x20	F2A/250V	ESKA	91.230.001	1	/01.7
-FU3	Pojistkové pouzdro	WK4/THS15...U	WIELAND	91.251.102	1	/03.1
-FU3	Pojistka trubičková 2A, 5x20	F2A/250V	ESKA	91.230.001	1	/03.1
-KW1	Pomocný kontakt ke stykači	MARN422AT	GE	91.041.005	1	/01.6
-KW1	Stykač 230V AC, 9A	MC1A 10E	GE	91.040.001	1	/03.9
-M1	Motor Pásu	TM 90 25 B5		91.001.027	1	/01.2
-M2	Čerpadlo 50W, 0,24A 3x400V, 50Hz	2C0P1-22 HP1		91.020.006	1	/01.6
-QS1	Hlavní vypínač 16A	P016	GIOVENZANA	91.170.003	1	/01.1
-QS1	Hlavní vypínač-ovládání	SE 16	GIOVENZANA	91.180.001	1	/01.1
-RF11	Filter k frekvenčnímu měnič 1,5kW	A1000-FV3010-RE	OMRON	91.012.027	1	/01.2
-RP1	Potenciometr 4k7	TP195 4k7-N20A	TES-Ostrava	91.283.002	1	/02.1
-RP1	Svorka rychloupínací	Svorka rychloupínací	WIELAND	91.250.009	3	/02.1
-SB1	Hlavice hřibového ovládače	ZB5 A5B44	TELEMECANIQUE	91.060.012	1	/03.2
-SB1	Rozpínací kontakt s adaptérem	ZB5AZ102	TELEMECANIQUE	91.061.006	1	/03.2
-SB1	Rozpínací kontakt	ZBE-102	TELEMECANIQUE	91.061.008	2	/02.2
-SB2	Hlavice zelená	ZB5AA3	TELEMECANIQUE	91.060.014	1	/03.6
-SB2	Kontakt s adaptérem-spínací	ZB5AZ101	TELEMECANIQUE	91.061.007	1	/03.6
-SB3	Hlavice červená	ZB5AA4	TELEMECANIQUE	91.060.015	1	/03.7
-SB3	Rozpínací kontakt s adaptérem	ZB5AZ102	TELEMECANIQUE	91.061.006	1	/03.7
-SQ1	Koncový spínač	D4N-4A31	OMRON	91.173.007	1	/03.3
-SQ2	Koncový spínač	D4N-4A31	OMRON	91.173.007	1	/03.4
-SQ3	Bezpečnostní koncový spínač	QKS8	KEDU	91.173.012	1	/03.5

Výrobce si vyhrazuje použít ekvivalentní náhrady přístrojů.

03 Datum

Ergonomic 320-250 G-DG-DGS | Bomar s.r.o.

04.a

Ust	04
Ust	6

0	1	2	3	4	5	6	7	8	9				
Kusovník artiklů													
Označení přístroje	Typ přístroje	Objednací číslo		Výrobce	Skladové číslo	Množství	Umístění (strana, sloupec)						
-T11	Transformátor 400V/230V/24V 20VA	JBC E2025 - 0173		ELEKTROKOV a.s. ZNOJMO	91.C80.003	1	/01.8						
<p>Výrobce si vyhrazuje použít ekvivalentní náhrady přístrojů.</p>													
04	Datum	Ergonomic 320-250 G-DG-DGS		Bomar s.r.o.									
					<table border="1"> <tr> <td>Lib.</td> <td>04.a</td> </tr> <tr> <td>Lib.</td> <td>b</td> </tr> </table>					Lib.	04.a	Lib.	b
Lib.	04.a												
Lib.	b												

6.5. Hydraulické schéma
 Hydraulisches Schéma
 Hydraulic diagram

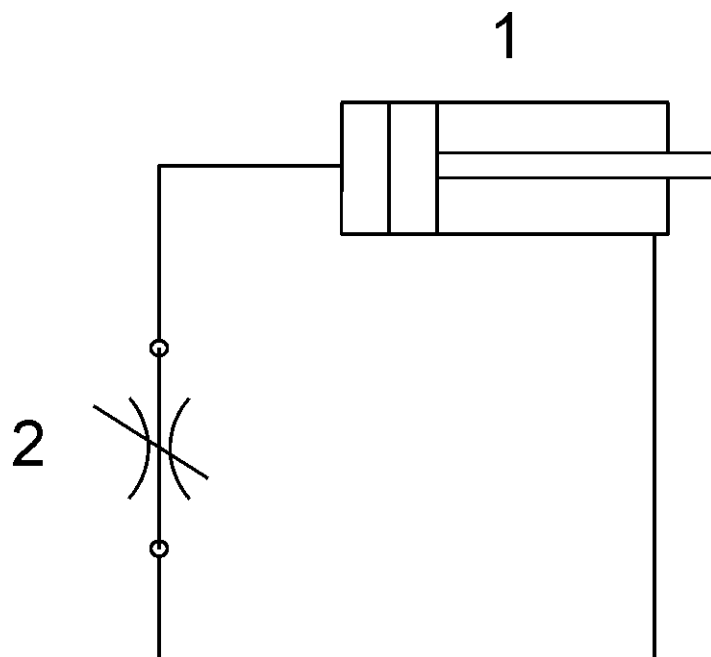

Poz.	Název položky		ks
Pos.	Bezeichnung		Menge
Pos.	Item		Pcs.
1	251.056	Hydraulický válec / Hydraulischer Zylinder / Hydraulic cylinder	1
2	92.152.002	Regulační ventil / Regelventil / Control valve HYTOS	1

7. Výkresy sestav pro objednání náhradních dílů / Zeichnungen für Bestellung der Ersatzteile / Drawing assemblies for spare parts order

- Při objednávání náhradních dílů vždy uvádějte: typ stroje (např. practix Ergonomic 320.250 G) , výrobní číslo (např. 125) a rok výroby (např. 1999).
- In die Bestellung der Ersatzteile führen Sie immer an: Maschinentyp (z. B. Ergonomic 320.250 G), Serien Nr. (z. B. 125) und Baujahr (z. B. 1999).
- For spare parts order, you must always to allege: type of machine (for example Ergonomic 320.250 G), serial number (for example 125, see cover page) and year of construction (for example 1999).

7.1. Ergonomic 320.250 G

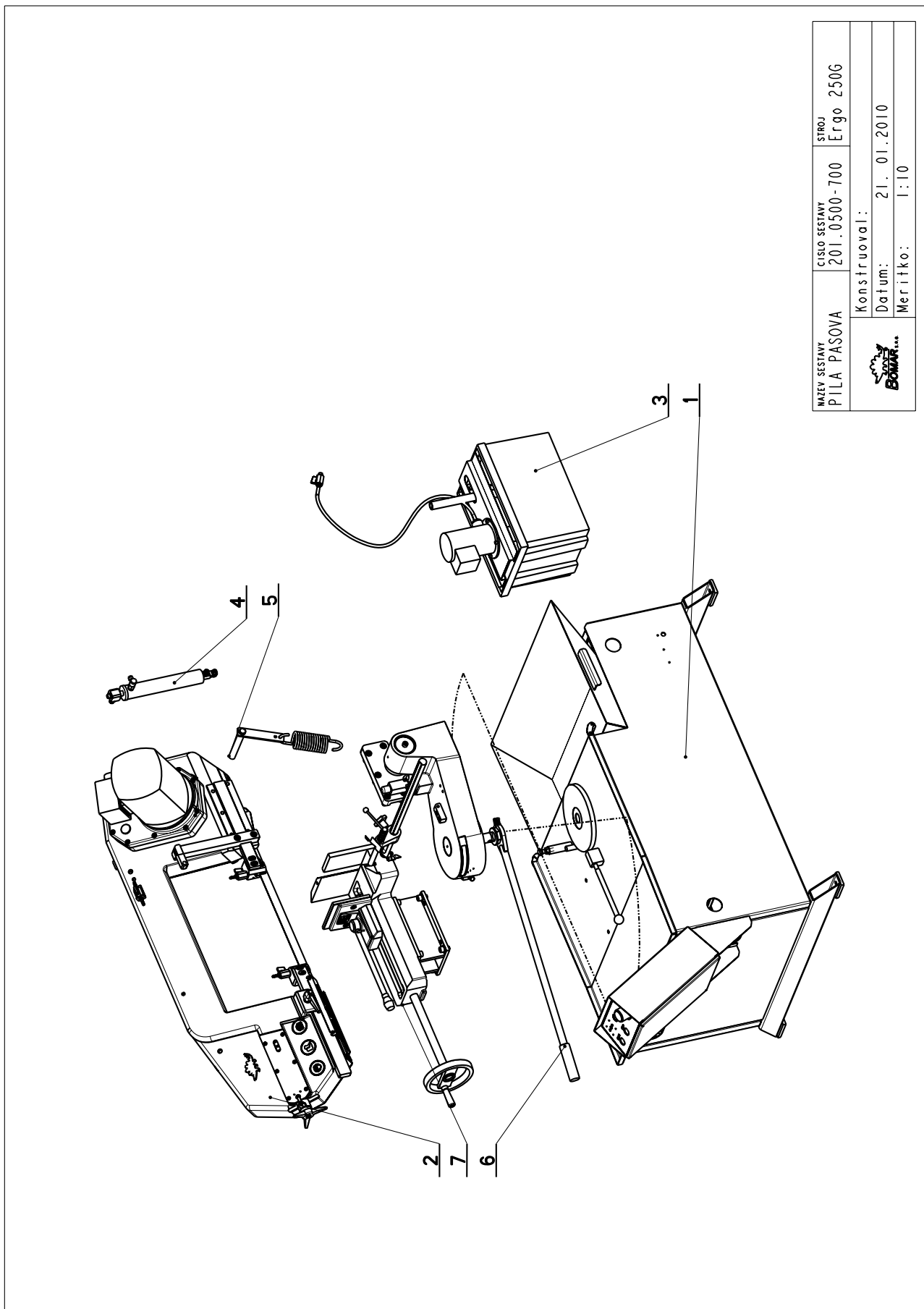

NAZEV SESTAVY PILA PASOVA	CÍSLO SESTAVY 201.0500-700	STROJ Ergo 250G
Konstruoval:		
Datum: 21. 01.2010		
Meritko: 1:10		

7.2. Kusovník / Stückliste / Piece list –
Ergonomic 320.250 G

Cislo Sestavy 201.0500-700		Ver. 1		Název sestavy PILA PASOVA/BAND SAW/BANDSÄGE	
Poz.	Objednací číslo	Ver.	Název položky	Rozměr	Ks
1	201.0501-500	4	PODSTAVEC / BASE / UNTERSATZ		1
2	201.0504-700	5	RAMENO / SHOULDER / SÄGERAHMEN		1
3	201.0506-000	0	CHLAZENÍ / COOLING / KÜHLUNG		1
4	201.0507-000	1	VALEC ZVEDACÍ / LIFTING CYLINDER / HEBEZYLINDER		1
5	201.0514-750	0	PRUŽINA / SPRING / FEDER		1
6	201.0702-000	2	KONZOLA OTOČNÁ / TURNABLE CONSOL / DREHKONSOLE		1
7	201.0703-000	0	SVERAK / VICE / SCHRAUBSTOCK		1
8	31.0104-026	0	SAMOLEPKA / STICKER / AUFLEBER		1
9	31.0599-005	0	SAMOLEPKA / STICKER / AUFLEBER		1
10	31.0599-801	0	STÍTEK / LABEL / SCHILD	P 0.5x65	1
11	99.900.040	0	SAMOLEPKA / STICKER / AUFLEBER		1
12	99.900.045	0	SAMOLEPKA / STICKER / AUFLEBER		1
13	99.900.047	0	SAMOLEPKA / STICKER / AUFLEBER		1
14	99.900.048	0	SAMOLEPKA / STICKER / AUFLEBER		1
15	99.900.049	0	SAMOLEPKA / STICKER / AUFLEBER		1
16	99.900.053	0	SAMOLEPKA / STICKER / AUFLEBER		1

1 ZM.Z ks. STROJE ZRUSIT PODSTAVEC 201.0501-000 A NAHRADIT JEJ CÍSEM 201.0501-500. 4.6.2008 VINOHRADSKY

7.3. Ergonomic 320.250 G

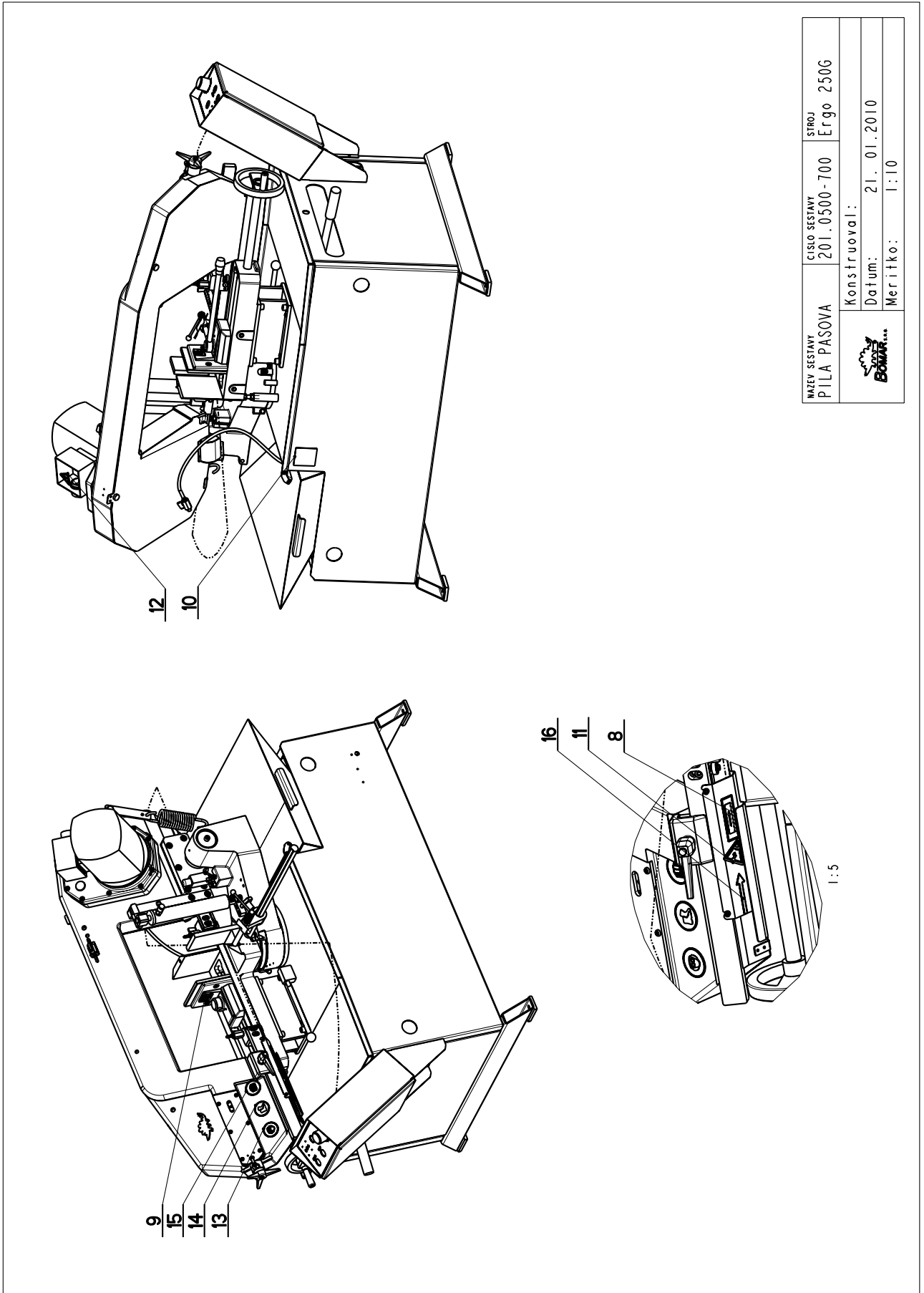

NAZEV SESTAVY PILA PASOVA	ČÍSLO SESTAVY 201.0500-700	STROJ Ergo 250G
Konstruoval:		
Datum: 21. 01.2010		
Meritko: 1:10		

7.4. Kusovník / Stückliste / Piece list –
Ergonomic 320.250 G

Císlo Sestavy 201.0500-700		Ver. 1		Název sestavy PILA PASOVA/BAND SAW/BANDSÄGE	
Poz.	Objednací číslo	Ver.	Název položky	Rozměr	Ks
1	201.0501-500	4	PODSTAVEC / BASE / UNTERSATZ		1
2	201.0504-700	5	RAMENO / SHOULDER / SÄGERAHMEN		1
3	201.0506-000	0	CHLAZENÍ / COOLING / KÜHLUNG		1
4	201.0507-000	1	VALEC ZVEDACÍ / LIFTING CYLINDER / HEBEZYLINDER		1
5	201.0514-750	0	PRUŽINA / SPRING / FEDER		1
6	201.0702-000	2	KONZOLA OTOČNÁ / TURNABLE CONSOL / DREHKONSOLE		1
7	201.0703-000	0	SVERAK / VICE / SCHRAUBSTOCK		1
8	31.0104-026	0	SAMOLEPKA / STICKER / AUFLEBER		1
9	31.0599-005	0	SAMOLEPKA / STICKER / AUFLEBER		1
10	31.0599-801	0	STITEK / LABEL / SCHILD	P 0.5x65	1
11	99.900.040	0	SAMOLEPKA / STICKER / AUFLEBER		1
12	99.900.045	0	SAMOLEPKA / STICKER / AUFLEBER		1
13	99.900.047	0	SAMOLEPKA / STICKER / AUFLEBER		1
14	99.900.048	0	SAMOLEPKA / STICKER / AUFLEBER		1
15	99.900.049	0	SAMOLEPKA / STICKER / AUFLEBER		1
16	99.900.053	0	SAMOLEPKA / STICKER / AUFLEBER		1

1 ZM.Z ks. STROJE ZRUSIT PODSTAVEC 201.0501-000 A NAHRADIT JEJ CÍSLEM 201.0501-500. 4.6.2008 VINOHRADSKY

7.5. Rameno / Sägerahmen / Saw arm

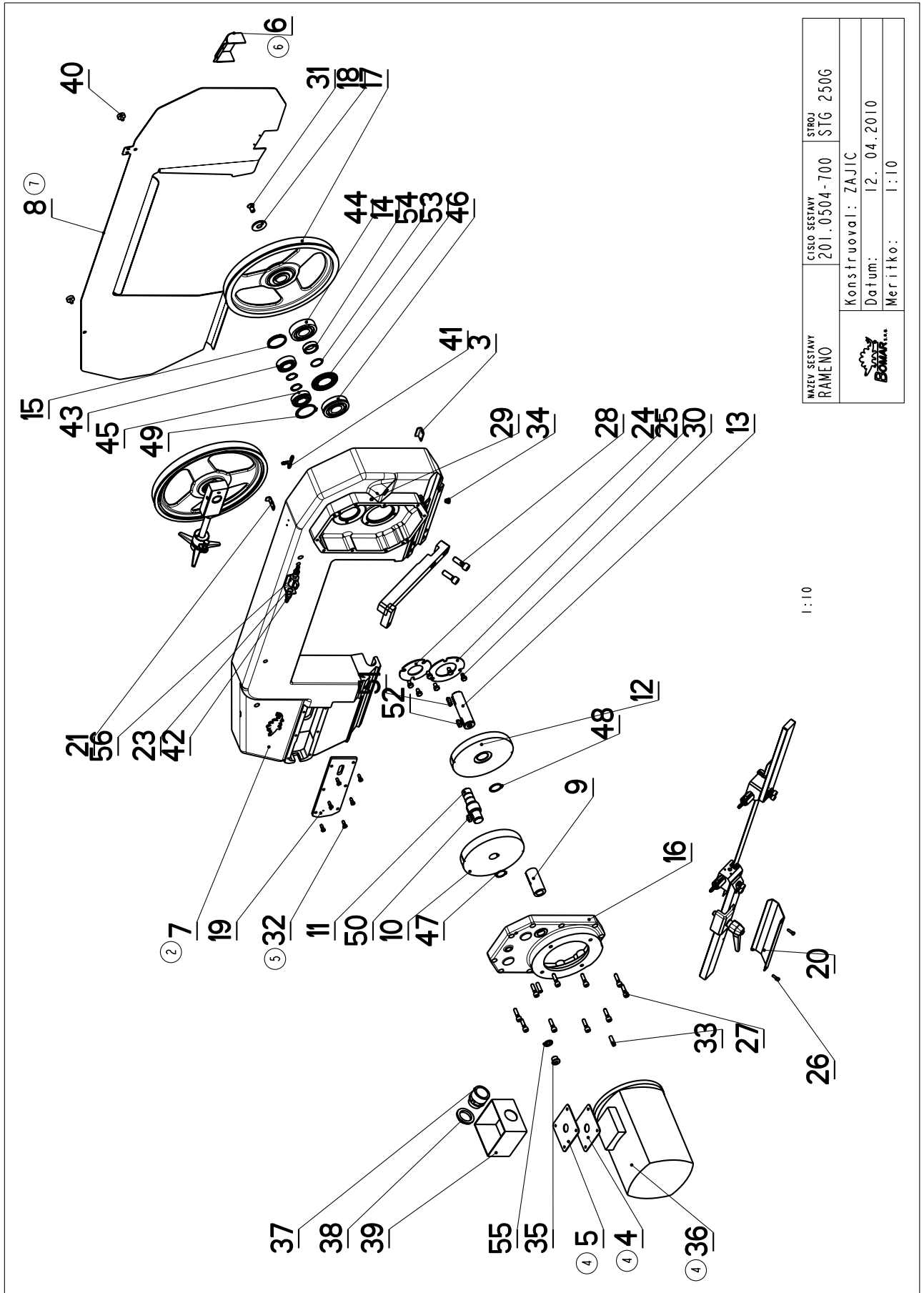

NAZEV SESTAVY RAMENO	CÍSLO SESTAVY 201.0504-700	STROJ STG 250G
Konstruoval: ZAJIC		
Datum: 12. 04.2010		
Meritko: 1:10		

7.6. Kusovník / Stückliste / Piece list –
Rameno / Sägerahmen / Saw arm

Císlo Sestavy 201.0504-700		Nozov sestavy RAMENO/SHOULDER/SÄGERAHMEN			
Poz.	Objednací číslo	Ver.	Nazev položky	Rozmer	Ks
1	201.0508-000	0	NAPINANI / TENSIONING / SPANNUNG		1
2	201.0510-000	1	VEDENÍ PASU / BELT GUIDE / SÄGEBANDFÜHRUNG		1
3	30.0104-029	0	UCHYTKA / CLIP / HALTER	P 2- 36	1
4	30.0504-010	4	DESKA ELEKTRO / ELECTRIC BOARD / PLATINE	P 1.5 - 95	1
5	30.0504-011	4	GUMA / RUBBER / GUMMI	TL.2-95	1
6	30.0504-604	6	KRYT / COVER / ABDECKUNG	P 1.5x84	1
7	30.0504-751	2	RAMENO / SHOULDER / SÄGERAHMEN	80.0504-701	1
8	30.0504-753	7	KRYT NAPINANI / TENSIONING COVER / BANDSPANNUNGSABDECKUNG	P 1.5-492	1
9	30.0505-002	0	PASTOREK / PINION / RITZEL	d 35	1
10	30.0505-003	1	KOLO OZUBENE / COG WHEEL / ZAHNRAD	D 176	1
11	30.0505-004	1	HRIDEL / SHAFT / WELLE	D40	1
12	30.0505-005	0	KOLO OZUBENE / COG WHEEL / ZAHNRAD	D 180	1
13	30.0505-007	1	HRIDEL / SHAFT / WELLE	TYC 35	1
14	30.0505-009	1	KROUZEK / RING / RING	Tr. 44.5x8	1
15	30.0505-013	0	ZATKA / PLUG / STOPFEN	d 55	1
16	30.0505-201	1	VÍKO / COVER / DECKEL	C.M.80.0705-001	1
17	30.0505-701	0	KOLO HMACI / DRIVE WHEEL / ANTRIEBSRAD	d 40	1
18	30.0508-002	0	PODLOZKA / WASHER / UNTERLEGSCHIEBE		1
19	30.0704-007	2	KRYT NAPINANI / TENSIONING COVER / BANDSPANNUNGSABDECKUNG	VYPALEK	1
20	30.0704-021	1	KRYT PASU / BELT COVER / BANDABDECKUNG	P 1.5-101	1
21	30.0704-032	2	PRÍLOZKA / STRAP / LASCHE	P 2 - 15	1
22	30.0707-012	1	DRZAK / HOLDER / HALTER		1
23	30.1814-011	0	DRZAK / HOLDER / HALTER	P 3- 76	1
24	81.0105-007	0	PRÍLOZKA / STRAP / LASCHE	P2.5-90	1
25	81.0505-010	0	PRÍLOZKA / STRAP / LASCHE	P 2.5- 108	1
26	90.001.25.009	0	SROUB IMBUS / ALLEN HEAD BOLT / IMBUSSCHRAUBE	M5X16	2
27	90.001.25.034	0	SROUB IMBUS / ALLEN HEAD BOLT / IMBUSSCHRAUBE	M8X30	10
28	90.001.25.059	0	SROUB IMBUS / ALLEN HEAD BOLT / IMBUSSCHRAUBE	M12X35	2
29	90.004.2D.001	0	SROUB STAVECI / ADJUSTMENT BOLT / STELLSCHRAUBE	SROUB M6X8	1
30	90.005.55.013	0	SROUB 6HRANNY / 6 SIDED BOLT / SECHSKANTSCHRAUBE	SROUB M8X12	6
31	90.011.27.008	0	SROUB ZAPUSŤOVNÝ / COUNTERSINK BOLT / SENKSCHRAUBE	SROUB M10X20	1
32	90.013.27.008	5	SROUB PULKULATÝ / HALF ROUND BOLT / HALBRUNDSCHRAUBE	M6X16	6
33	90.302.0Z.002	0	KOLÍK KUZELOVÝ / TAPER PIN / KEGELBOLZEN	KOLÍK 8X30	2
34	90.400.5Z.001	0	ZATKA / PLUG / STOPFEN	M10x1	1
35	90.400.5Z.002	0	ZATKA / PLUG / STOPFEN	M16x1.5	1
36	91.001.007	4	ELEKTROMOTOR / ELECTRIC MOTOR / ELEKTROMOTOR		1

7.7. Rameno / Sägerahmen / Saw arm

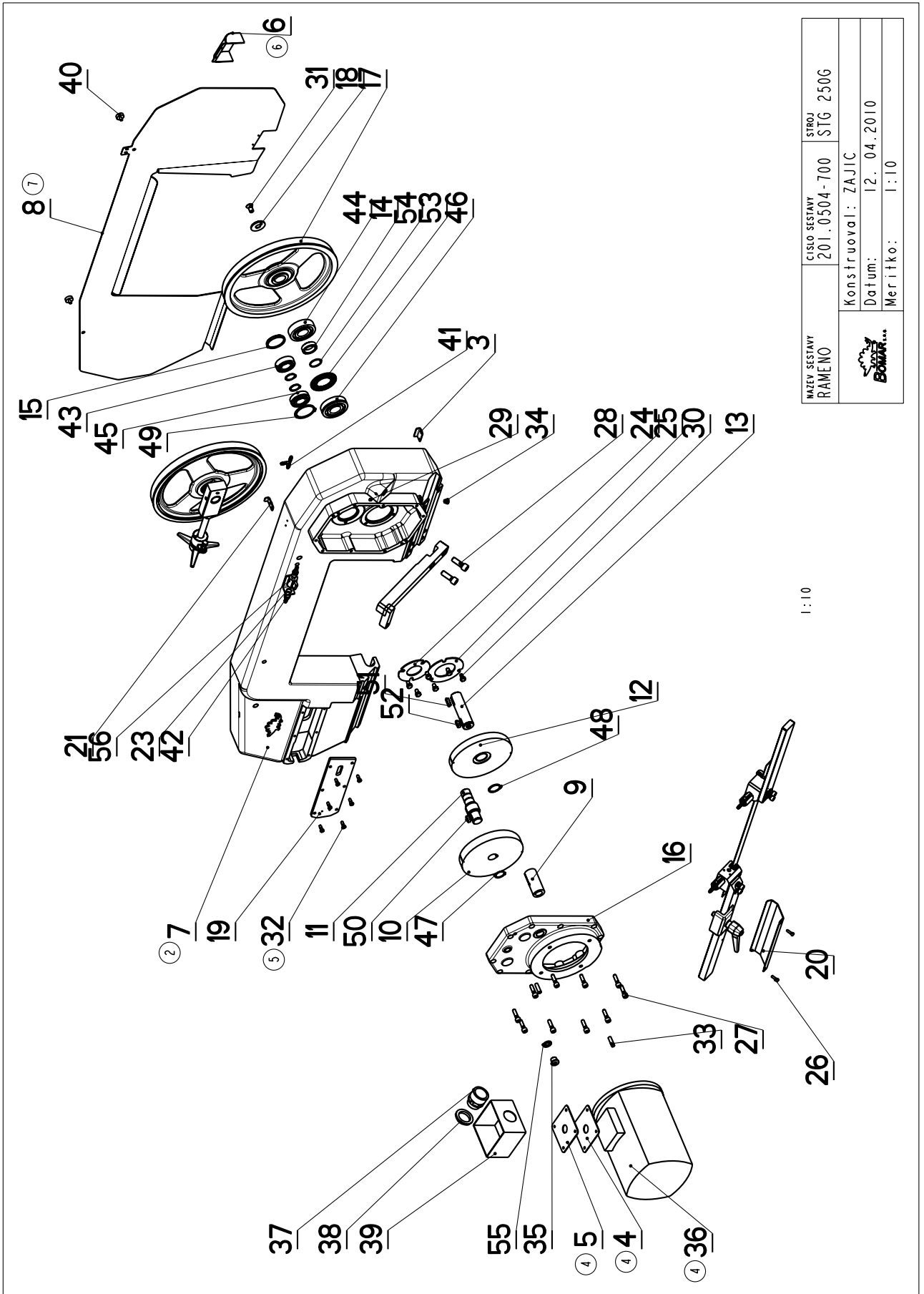

1:10

NAZEV SESTAVY RAMENO	ČÍSLO SESTAVY 201.0504-700	STROJ STG 250G
Konstruoval: ZAJIC		
Datum: 12. 04.2010		
Meritko: 1:10		

7.8. Kusovník / Stückliste / Piece list –
Rameno / Sägerahmen / Saw arm

Císlo Sestavy 201.0504-700		Nozav sestavy RAMENO/SHOULDER/SÄGERAHMEN			
Pož.	Objednací číslo	Ver.	Název položky	Rozměr	Ks
37	91.071.004	0	VYVODKA / BUSHING / TÜLLE	VYVODKA	1
38	91.072.007	0	MATICE / NUT / MUTTER	MATICE	1
39	91.190.004	0	KRABICE ELEKTRO / ELECTRO BOX / ELEKTRODOSE		1
40	94.007.002	0	SROUB / BOLT / SCHRAUBE		2
41	94.200.001	0	REDUKCE / REDUCTION / ADAPTOR / REDUKTION	6	1
42	94.202.002	0	REDUKCE / REDUCTION / ADAPTOR / REDUKTION	GES 6/R1/4"	2
43	95.001.018	0	LOŽISKO / BEARING / LAGER	6205 ZRS	1
44	95.001.025	0	LOŽISKO / BEARING / LAGER	6306 ZRS	1
45	95.003.002	0	LOŽISKO / BEARING / LAGER	6205AN	1
46	95.003.003	0	LOŽISKO / BEARING / LAGER	6306AN	1
47	95.800.012	0	KROUZEK POJIST.VNEJS / OUTSIDE SAFETY RING / SICHERUNGSRING AUßEN	POJISTNY KROUZEK 25	3
48	95.800.013	0	KROUZEK POJIST.VNEJS / OUTSIDE SAFETY RING / SICHERUNGSRING AUßEN	POJISTNY KROUZEK 30	1
49	95.800.019	0	KROUZEK POJIST.VNEJS / OUTSIDE SAFETY RING / SICHERUNGSRING AUßEN	POJISTNY KROUZEK 52	1
50	95.810.006	0	PERO / SPRING / FEDER	PERO 8X7X20	1
51	95.810.007	0	PERO / SPRING / FEDER	PERO 8X7X25	1
52	95.810.023	0	PERO / SPRING / FEDER	PERO 8X7X22	1
53	95.830.005	0	GUFERO / GIT SEAL / DICHTUNG	GUFERO 40X72X7	1
54	96.002.034	0	KROUZEK O DYNAMICKY / DYNAMIC O RING / O-RING DYNAMISCH	30X2	1
55	96.081.001	0	KROUZEK TESNICI / SEAL RING / DICHTUNGSRING	23x15x3	1
56	99.260.003	0	VENTIL / VALVE / VENTIL	1/4"	1

1. ZRUSENA SOUCAST 30.0504-004 A NAHR. 30.0504-010 , ZRUSENA SOUCAST 30.0504-005 A NAHR. 30.0504-011. 24.10.2005 SLEZACKOVA

2. VYMENA RAMENE A KRYTU RAMENE, ZRUSENY SOUC. 30.0504-701, 30.0504-702 A NAHR. 30.0504-751, 30.0504-752. 558/ZM281 16.10.2006 SLEZACKOVA

3. ZRUS.PLECH ELEKTRO 30.0504-010 A NAHR. 30.0504-012,ZRUS.GUMA 30.0504-011 A NAHR. 30.0504-013,ZRUS.MOTOR 91.001.007 A NAHR. 91.001.129 318/ZM295 11.9.2008 SLEZACKOVA

4. VYMENA MOTORU - ZRUS.MOTOR CINSKY 91.001.129 A NAHR.MOTOREM EMP SLAVKOV 91.001.129,ZRUS.PLECH ELEKTRO 30.0504-012 A NAHR. PLECHEM 30.0504-010, ZRUS.GUMA 30.0504-013 A NAHR.GUMOU 30.0504-011. 061/ZM085 25.3.2009 SLEZACKOVA

5. ZRUS.KARTACEK 201.0704-100,PRID.KRYT KARTACKU 30.0504-603,ZRUS.SROUB IMBUS M6x16 (90.001.25.017) A NAHRAZEN SROUBEM S PULKULATOU HLAVOU M6x16 (90.013.27.008). 183/ZM211 26.11.2009 SLEZACKOVA

6. ZRUSEN KRYT KARTACKU 30.0504-603 A NAHRAZEN 30.0504-604. 052/ZM050 22.2.2010 SLEZACKOVA

7. ZRUSEN KRYT 30.0504-752 A NAHRAZEN 30.0504-753. 036/ZM095 12.4.2010 SLEZACKOVA

7.9. Konzola / Konzole / Console

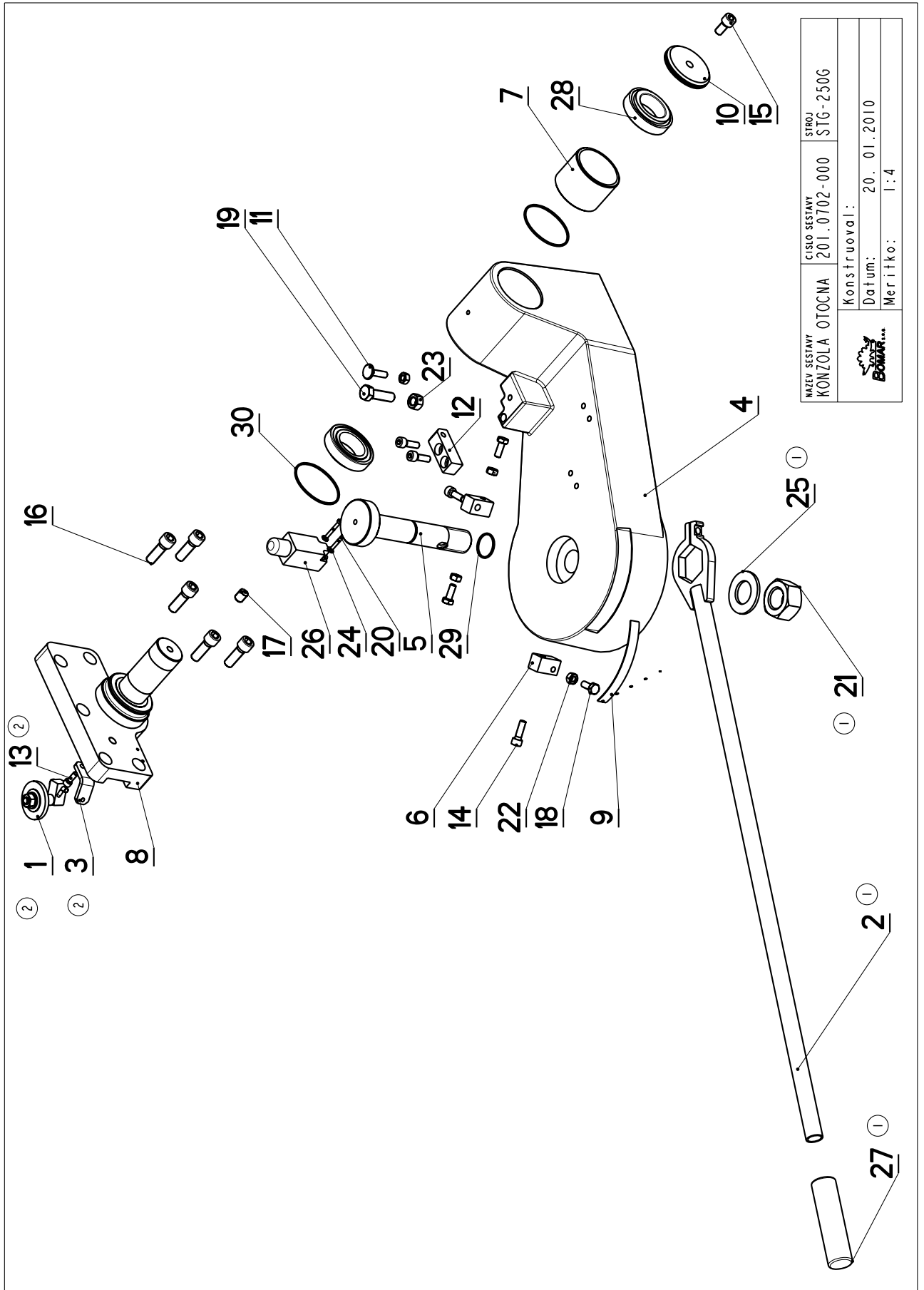

7.10. Kusovník / Stückliste / Piece list -
Konzola / Konsole / Console

Císlo Sestavy 201.0702-000		Ver. 2		Nozov sestavy KONZOLA OTOCNA/TURNABLE CONSOL/DREHKONSOLE	
Poz.	Objednací číslo	Ver.	Nazev položky	Rozmer	Ks
1	201.0704-100	0	KARTAC / BRUSH / BÜRSTE		1
2	30.0502-004	1	PAKA / LEVER / HEBEL	SVARENO	1
3	30.0514-603	2	DRZAK / HOLDER / HALTER	HR20x5	1
4	30.0702-001	2	KONZOLA / CONSOLE / KONSOLE		1
5	30.0702-002	2	CEP / LUG / BOLZEN	M30x173	1
6	30.0702-006	0	DORAZ / STOP PIECE / ANSCHLAG	TYC 20x20	2
7	30.0702-008	0	POUZDRO / SLEEVE / BÜCHSE	TR 70x5	1
8	30.0702-010	0	DRZAK / HOLDER / HALTER		1
9	30.0702-011	0	STUPNICE / SCALE / SKALA	P1-15	1
10	30.0702-012	0	VÍKO / COVER / DECKEL	d 70	1
11	30.0702-013	0	SROUB / BOLT / SCHRAUBE	M8	1
12	30.0707-011	0	DRZAK / HOLDER / HALTER	TYC 20x20	1
13	90.001.25.017	2	SROUB IMBUS / ALLEN HEAD BOLT / IMBUSSCHRAUBE	M6x16	1
14	90.001.25.033	0	SROUB IMBUS / ALLEN HEAD BOLT / IMBUSSCHRAUBE	8x25	4
15	90.001.25.046	0	SROUB IMBUS / ALLEN HEAD BOLT / IMBUSSCHRAUBE	M10x20	1
16	90.001.25.059	0	SROUB IMBUS / ALLEN HEAD BOLT / IMBUSSCHRAUBE	M12x35	5
17	90.002.2D.017	0	SROUB STAVECI / ADJUSTMENT BOLT / STELLSCHRAUBE	SROUB M12x16	1
18	90.005.55.015	0	SROUB 6HRANNY / 6 SIDED BOLT / SECHSKANTSCHRAUBE	SROUB M8x20	3
19	90.005.55.034	0	SROUB 6HRANNY / 6 SIDED BOLT / SECHSKANTSCHRAUBE	SROUB M12x40	1
20	90.012.50.007	0	SROUB / BOLT / SCHRAUBE	SROUB M4x30	2
21	90.100.25.001	1	MATICE / NUT / MUTTER	MATICE - M30	1
22	90.100.55.005	0	MATICE / NUT / MUTTER	MATICE - M8	4
23	90.100.55.007	0	MATICE / NUT / MUTTER	MATICE - M12	1
24	90.150.50.002	0	PODLOZKA / WASHER / UNTERLEGSCHIEBE	PODLOZKA 4,3	2
25	90.150.50.000	1	PODLOZKA / WASHER / UNTERLEGSCHIEBE	PODLOZKA 31	1
26	91.173.007	0	SPINAC KONCOVY / END SWITCH / ENDSCHALTER	-R1WK	1
27	94.004.502	1	RUKOJET / HANDLE / GRIFF	D22	1
28	95.300.002	0	LOZISKO / BEARING / LAGER	32008AX	2
29	96.001.008	0	KROUZEK O STATICKY / STATIC O RING / O-RING STATISCH	26x2	1
30	96.001.018	0	KROUZEK O STATICKY / STATIC O RING / O-RING STATISCH	63x2	2

1. ZM. Z ks. STROJE ZRUSENO: 30.0301-012, 30.0502-002, 30.0502-001, 94.00.2.001, NOVE SOUCASTI: 30.0502-004
94.00.502, 90.100.25.001, 90.150.50.018. 11.6.2008 VINOHRADSKY

2. PRIDAN KARTACEK 201.0704-100, DRZAK KARTACKU 30.0514-603 A SROUB M6x16 (90.001.25.017, 183/ZM211 29.10.2009 SLEZACKOVA

7.11. Svěrák / Schraubstock / Vice

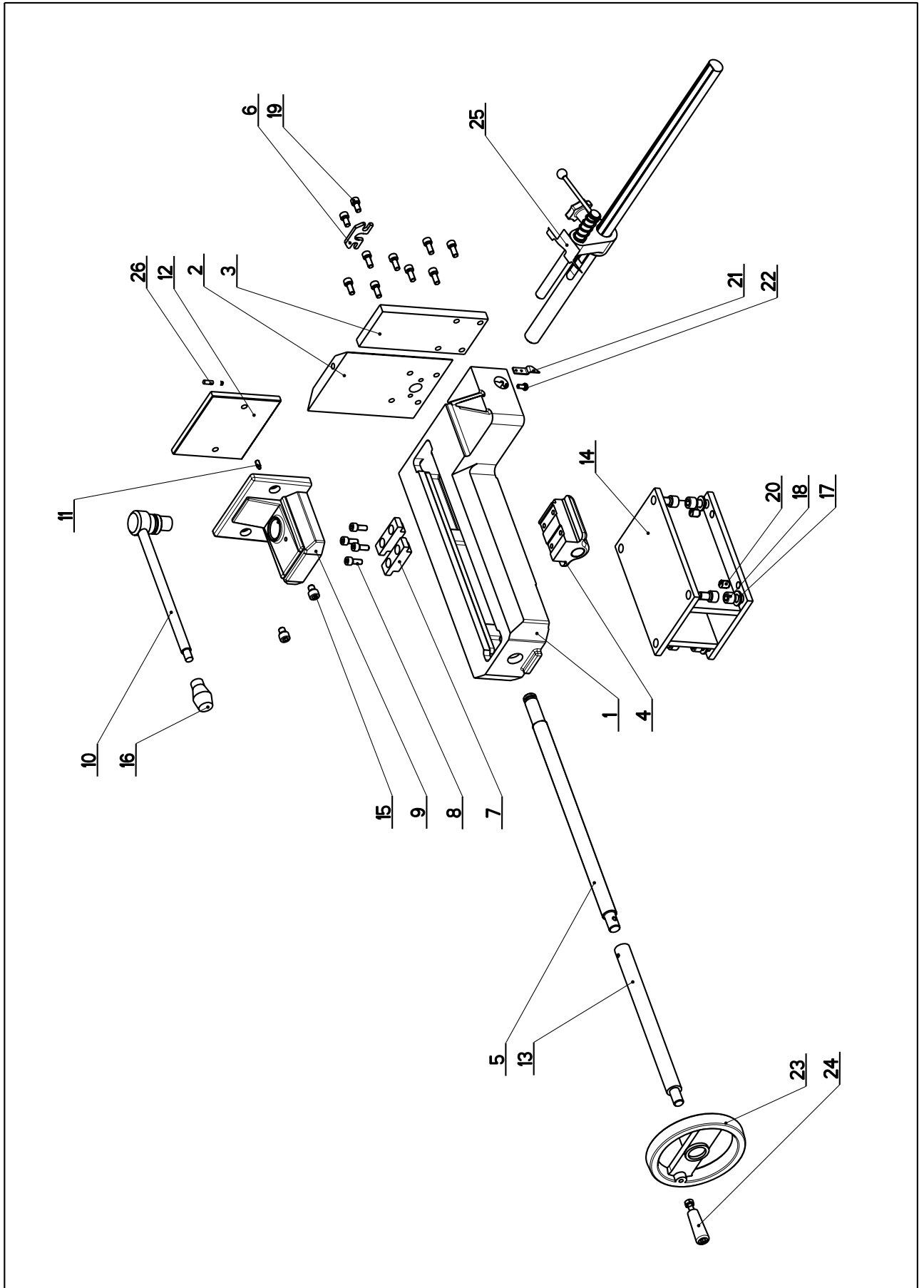

7.12. Kusovník / Stückliste / Piece list – Svěrák / Schraubstock / Vice

Cisto Setlisty 201.0703-000		Ver. 0	Mater. sestavy SVĚRÁK/VICE / SCHRAUBSTOCK		
Poz.	Objednací číslo	Ver.	Mater. položky	Rozměr	Ks
1	30.0703-001	2	SVĚRÁK / VICE / SCHRAUBSTOCK		1
2	30.0703-019	0	CELIST / JAW / BÄCKE	HR 150x20	1
3	30.0703-020	0	CELIST / JAW / BÄCKE	HR 90x15	1
4	30.0703-015	2	MATICE / NUT / MUTTER	ODLITEK	1
5	30.0703-005	1	SROUB / BOLT / SCHRAUBE	TR24x5L	1
6	30.0103-006	1	PŘILOŽNA / STRAP / LASCHE	HR 60 x 5	1
7	30.0703-004-1	1	VEDENÍ / GUIDE / BACKENFÜHRUNG	20x20	2
8	90.001.25.032	0	SROUB IMBUS / ALLEN HEAD BOLT / IMBUSSCHRAUBE	6x20	12
9	30.0703-002	3	CELIST / JAW / BÄCKE		1
10	30.0703-003	0	EXCENTR / CAM / EXZENTER		1
11	90.004.20.003	0	SROUB STAVECI / ADJUSTMENT BOLT / STELLSCHRAUBE	SROUB M6x16	1
12	30.0703-018	0	CELIST / JAW / BÄCKE	HR 130x10	1
13	30.0103-008	1	TYC / POLE / STANGE	ø 25	1
14	30.0703-009	0	KONZOLA / CONSOLE / KONSOLE		1
15	90.001.25.043	0	SROUB IMBUS / ALLEN HEAD BOLT / IMBUSSCHRAUBE	M10x12	2
16	94.002.001	0	HLAVICE / HEAD / KOPF		1
17	90.150.50.007	0	PODLOŽNA / WASHER / UNTERLEGSCHIBE	PODLOŽKA 13	4
18	90.001.25.056	0	SROUB IMBUS / ALLEN HEAD BOLT / IMBUSSCHRAUBE	M12x20	8
19	90.001.25.031	0	SROUB IMBUS / ALLEN HEAD BOLT / IMBUSSCHRAUBE	6x16	2
20	90.002.20.017	0	SROUB STAVECI / ADJUSTMENT BOLT / STELLSCHRAUBE	SROUB M12x16	4
21	30.0703-011	0	UKAZATEL / INDICATOR / ZEIGER	P 1.5 - 12	1
22	90.005.55.006	0	SROUB GHŘANÝ / 6 SIDED BOLT / SECHSKANTSCHRAUBE	SROUB M6x12	1
23	94.010.001	0	KOLEČKO / WHEEL / ROLLE		1
24	94.010.002	0	RUKOJET / HANDLE / GRIF		1
25	201.0703-100	0	DORAZ / STOP PIECE / ANSCHLAG		1
26	90.301.02.005	0	ROLIK VALCOVÝ MĚKKÝ / CYLINDRICAL PIN SOFT / ZYLINDERSTIFT WEICH	ROLIK 6x36	1

7.13. Válec zvedací / Hebezyylinder / Liftink cylinder

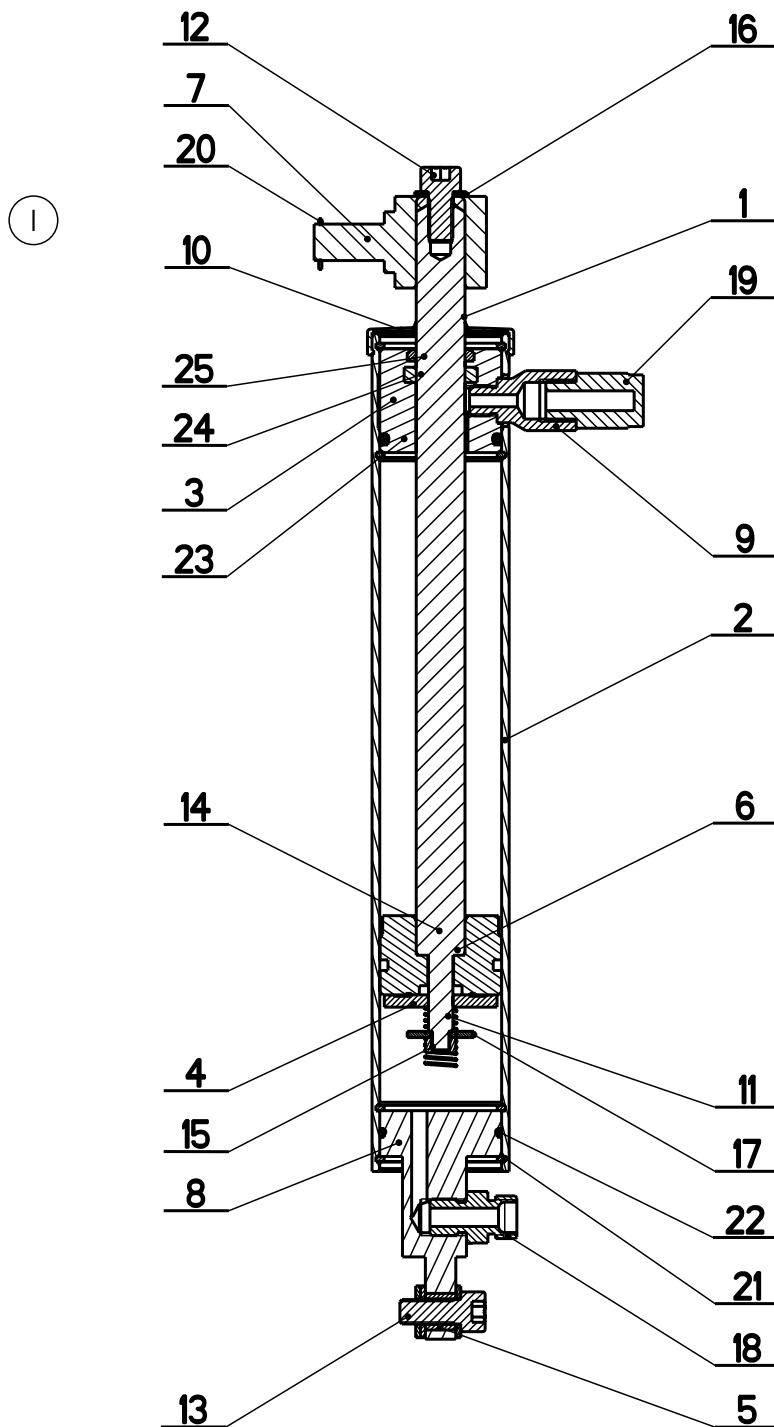

NAZEV SESTAVY VALEC ZVEDACI	CISLO SESTAVY 201.0507-000	STROJ
	Konstruoval: STASTNY	
	Datum: 20. 01.2010	
	Meritko: 1:2	

7.14. Kusovník / Stückliste / Piece list –
Válec zvedací / Hebezyylinder / Liftink cylinder

Číslo sestavy 201.0507-000		Název sestavy VALEC ZVEDACÍ/LIFTING CYLINDER/HEBEZYLINDER			
Poz.	Objednací číslo	Ver.	Název položky	Rozměr	Ks
1	30.0507-001	0	PISTNICE / PISTON ROD / KOLBENSTANGE	d 1618	1
2	30.0507-002	1	VALEC / ROLLER / ZYLINDER	TRUBKA 45/40	1
3	30.0507-003	0	VÍKO / COVER / DECKEL	d 45	1
4	30.0507-004	1	KLAPKA / PULLEY / VENTILKLAPPE	d 38	1
5	30.0507-005	1	POUZDRO / SLEEVE / BÜCHSE	d 12	1
6	30.0707-001	0	PIST / PISTON / KOLBEN	d 45	1
7	30.0707-009	0	DRZAK / HOLDER / HALTER	HR 30x 30	1
8	30.0907-001	0	DRZAK / HOLDER / HALTER	d 40	1
9	30.3407-103	1	REDUKCE / REDUCTION / ADAPTOR / REDUKTION	TYC 17	1
10	31.0507-010	1	VÍKO / COVER / DECKEL		1
11	31.0707-014	0	PRUŽINA / SPRING / FEDER	0.63x10x20x9.5	1
12	90.001.25.031	0	SROUB IMBUS / ALLEN HEAD BOLT / IMBUSSCHRAUBE	8x16	1
13	90.001.25.032	0	SROUB IMBUS / ALLEN HEAD BOLT / IMBUSSCHRAUBE	8x20	1
14	90.003.2D.003	0	SROUB STAVECI / ADJUSTMENT BOLT / STELLSCHRAUBE	SROUB M5X12	1
15	90.100.55.004	0	MATICE / NUT / MUTTER	MATICE - M6	1
16	90.150.50.005	0	PODLOZKA / WASHER / UNTERLEGSCHEIBE	PODLOZKA 8,4	4
17	90.151.50.004	0	PODLOZKA / WASHER / UNTERLEGSCHEIBE	PODLOZKA 6	1
18	92.002.001	0	SROUBENI PRIME / DIRECT BOLTING / GERADE VERSCHRAUBUNG	G 1/4"	1
19	93.009.002	0	SROUBENI UHLOVE / ANGLE BOLTING / WINKELVERSCHRAUBUNG		1
20	95.800.004	0	KROUZEK POJIST.VNEJS / OUTSIDE SAFETY RING / SICHERUNGSRING AUßEN	POJISTNY KROUZEK 12	1
21	95.801.005	0	KROUZEK POJIST.VNITR / INSIDE SAFETY RING / SICHERUNGSRING INNEN	POJISTNY KROUZEK 40	4
22	96.001.010	0	KROUZEK TESNICI / SEAL RING / DICHTUNGSRING	d36x2	1
23	96.002.017	0	KROUZEK O STATICKY / STATIC O RING / O-RING STATISCH	d34x3	1
24	96.041.001	0	TESNENI / SEALING / DICHTUNG	d16	1
25	96.060.001	0	KROUZEK STRACI / SCRAPER RING / ABSTREIFRING	16x22	1

1.dopl.položka 31.0507-010, 8.6.04 Státny

7.15. Podstavec / Untersatz / Base

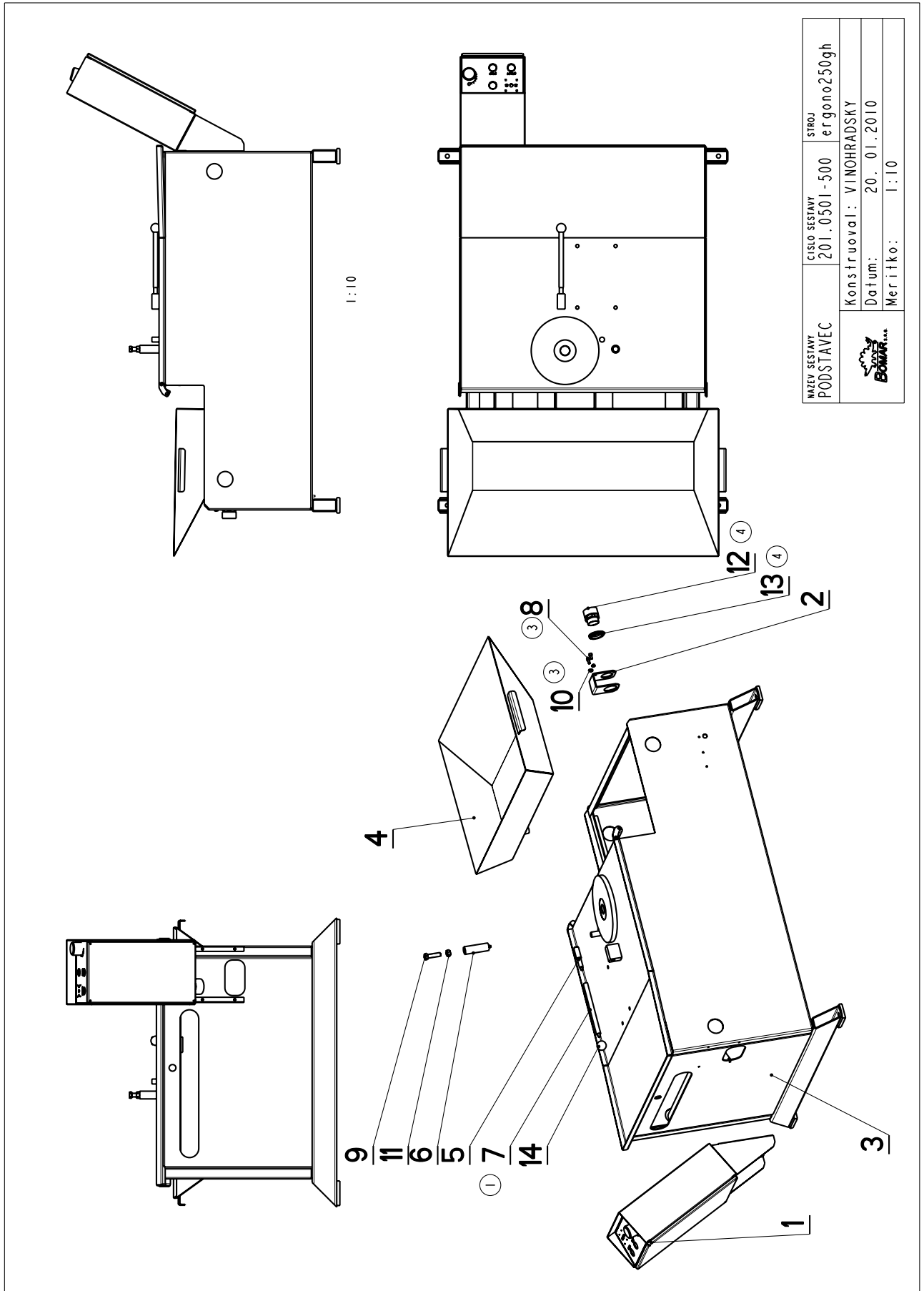



7.16. Kusovník / Stückliste / Piece list –
Podstavec / Untersatz / Base

Cislo Sestavy 201.0501-500		Ver. 4		Nazev sestavy PODSTAVEC / BASE / UNTERSATZ	
Poz.	Objednací číslo	Ver.	Nazev položky	Rozmer	Ks
1	201.0513-000	0	OVLADACÍ PANEL / CONTROL PANEL / BEDIENPULT		1
2	30.0501-003	1	DRŽAK / HOLDER / HALTER	P3 - 60	1
3	30.0501-501	5	PODSTAVEC / BASE / UNTERSATZ		1
4	30.0501-602	1	VANA / TANK / WANNE		1
5	30.0701-016	0	DORAZ / STOP PIECE / ANSCHLAG	d 16h9	1
6	30.0701-027	0	CEP / LUG / BOLZEN	d 25	1
7	30.1003-004	0	MASTAVEC / EXTENSION / ANSATZ	d 14	1
8	90.001.25.016	0	SROUB IMBUS / ALLEN HEAD BOLT / IMBUSSCHRAUBE	M6x12	2
9	90.005.55.035	0	SROUB 6HRANNY / 6 SIDED BOLT / SECHSKANTSCHRAUBE	SROUB M12x45	1
10	90.100.55.004	0	MATICE / NUT / MUTTER	MATICE - M6	2
11	90.100.55.007	0	MATICE / NUT / MUTTER	MATICE - M12	1
12	91.072.004	0	VYVODKA / BUSHING / TÜLLE	VYVODKA	1
13	91.072.007	0	MATICE / NUT / MUTTER	MATICE	1
14	94.001.002	0	HLAVICE / HEAD / KOPF		1

1. PRIDAN NADSTAVEC 30.1003-004. 403/ZM393 14.11.2008 SLEZACKOVA
2. ZM. POLOHY OVLADACIHO PANELU. 048/ZM069 9.3.2009 SLEZACKOVA
3. ZRUS. 2xSROUB M5x6 (90.001.25.006) A NAHR. 2xSROUB M6x12 (90.001.25.016), PRID. 2xMATICE M6 (90.100.55.004).
113/ZM135 10.6.2009 SLEZACKOVA
4. ZRUS. VYVODKA PG36 (91.071.005) A NAHR. VYVODKOU PG29 (91.071.004), ZRUS. MATICE PG36 (91.072.008)
A NAHR. MATICI PG29 (91.072.007). 133/ZM163 20.7.2009 SLEZACKOVA

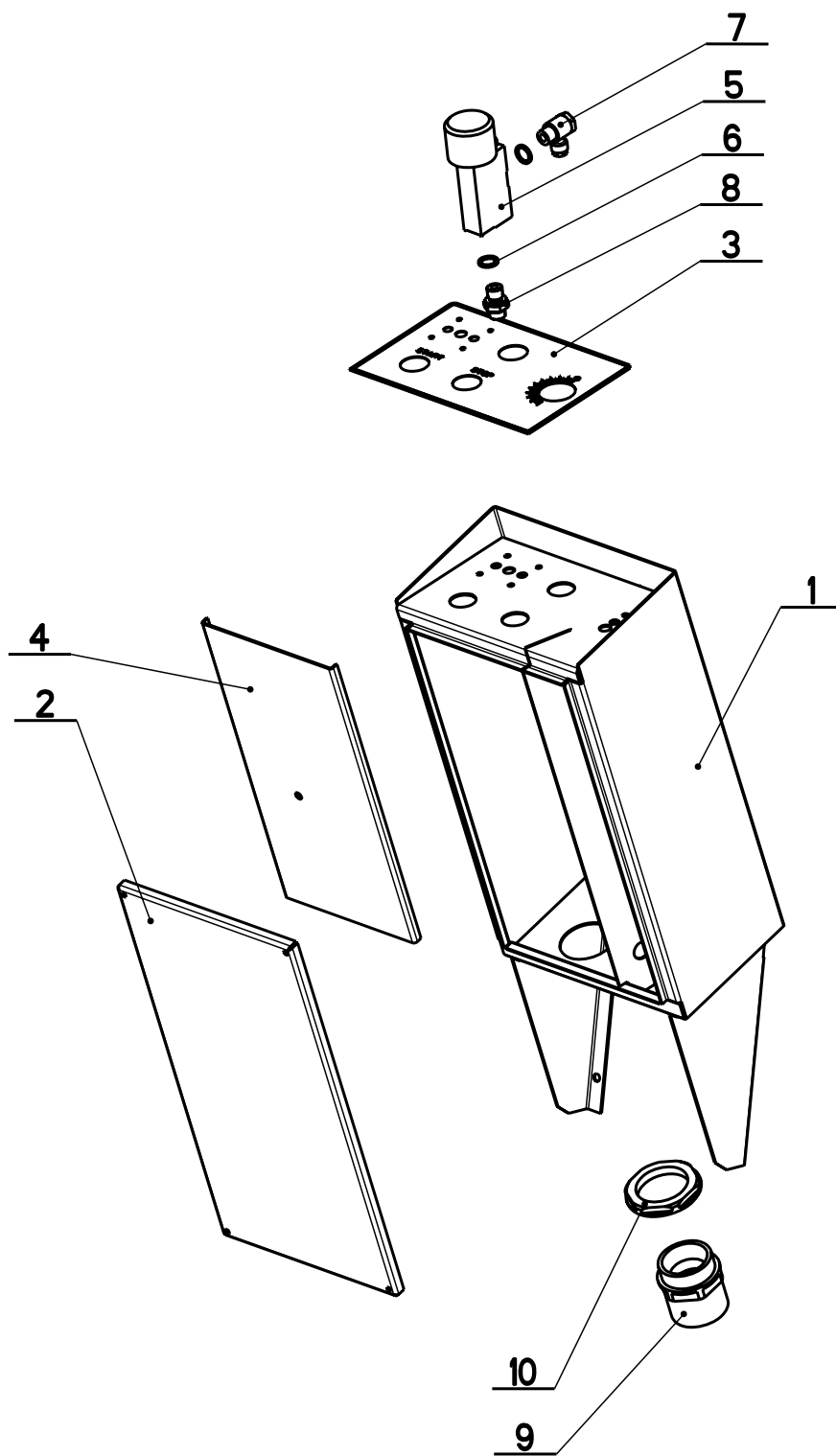
7.17. Ovládací panel / Bedienpult / Control panel





NAZEV SESTAVY OVLADACÍ PANEL	CÍSLO SESTAVY 201.0513-000	STROJ G.DG
	Konstruoval:	
	Datum: 20. 01.2010	
	Meritko: 1:5	

7.18. Kusovník / Stückliste / Piece list –
Ovládací panel / Bedienpult / Control panel

Císlo sestavy 201.0513-000		Název sestavy OVLADACÍ PANEL/CONTROL PANEL/BEDIENPULT			
Poz.	Objednací číslo	Ver.	Můzvev položky	Rozměr	Ks
1	30.0513-001	0	PANEL ELEKTRO / ELECTRO PANEL / PANEL		1
2	30.0513-003	0	VÍRO / COVER / DECKEL	P11.5x214	1
3	31.0513-004	0	PANEL ELEKTRO / ELECTRO PANEL / PANEL	P0.8x135	1
4	30.0513-002	0	DESKA ELEKTRO / ELECTRIC BOARD / PLATINE	P11.5-166	1
5	92.152.001	0	VENTIL SRTICI / CHOKE VALVE / DROSSELVENTIL	VS01-04/R 2.5-0	1
6	96.082.002	0	TESNĚNÍ / SEALING / DICHTUNG	KROUZEK CU 13/17	2
7	93.009.002	0	SROUBENÍ ÚHLOVÉ / ANGLE BOLTING / WINKELVERSCHRÄUBUNG		1
8	92.002.003	0	SROUBENÍ PRÍME / DIRECT BOLTING / GERADE VERSCHRÄUBUNG		1
9	91.071.005	0	PRUCHODNA / LEADTHROUGH / DURCHFÜHRUNG		1
10	91.072.008	0	MATICE / NUT / MUTTER		1

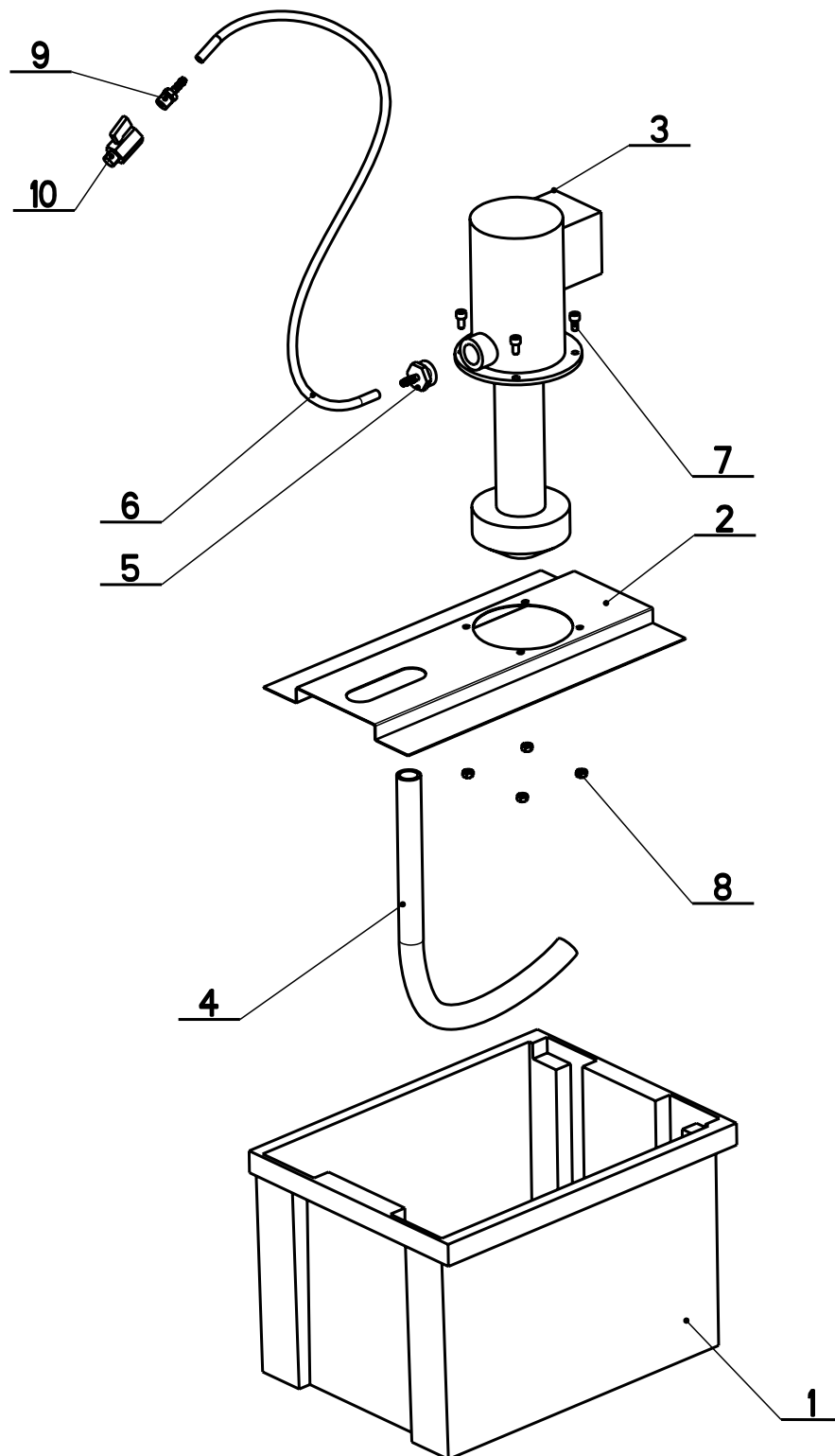
7.19. Chlazení / Kühlung / Cooling



NAZEV SESTAVY CHLAZENÍ	CISLO SESTAVY 201.0506-000	STROJ STG-120
	Konstruoval: ZAJIC	
	Datum: 20. 01.2010	
	Meritko: 17:100	

7.20. Kusovník / Stückliste / Piece list –
Chlazení / Kühlung / Cooling

Cislo Sestavy 201.0506-000		Ver. 0		Název sestavy CHLAZENÍ/COOLING/KÜHLUNG	
Poz.	Objednací číslo	Ver.	Název položky	Rozměr	Ks
1	94.403.001	0	MADRZ / CONTAINER / BEHÄLTER	POLYPACK	1
2	30.0506-001	3	VÍKO / COVER / DECKEL	P 0.8 - 249	1
3	91.020.006	0	CERPADLO CHLAZENÍ / COOLING PUMP / KÜHLMITTEL PUMPE	3COA 2-22	1
4	42.020.003	0	HADICE / HOSE / SCHLAUCH	19x3	1
5	94.202.005	0	REDUKCE / REDUCTION / ADAPTOR / REDUKTION	3/4"-6	1
6	42.020.001	0	HADICE / HOSE / SCHLAUCH	6x1.5	1
7	90.001.25.016	0	SROUB IMBUS / ALLEN HEAD BOLT / IMBUSSCHRAUBE	M6X12	4
8	90.100.55.004	0	MATICE / NUT / MUTTER	MATICE - M6	4
9	94.202.002	0	REDUKCE / REDUCTION / ADAPTOR / REDUKTION	REDUKCE 6/RI/4"	1
10	99.260.001	0	VENTIL / VALVE / VENTIL	VENTIL KULOVY	1

7.21. Napínání / Spannung / Tensioning

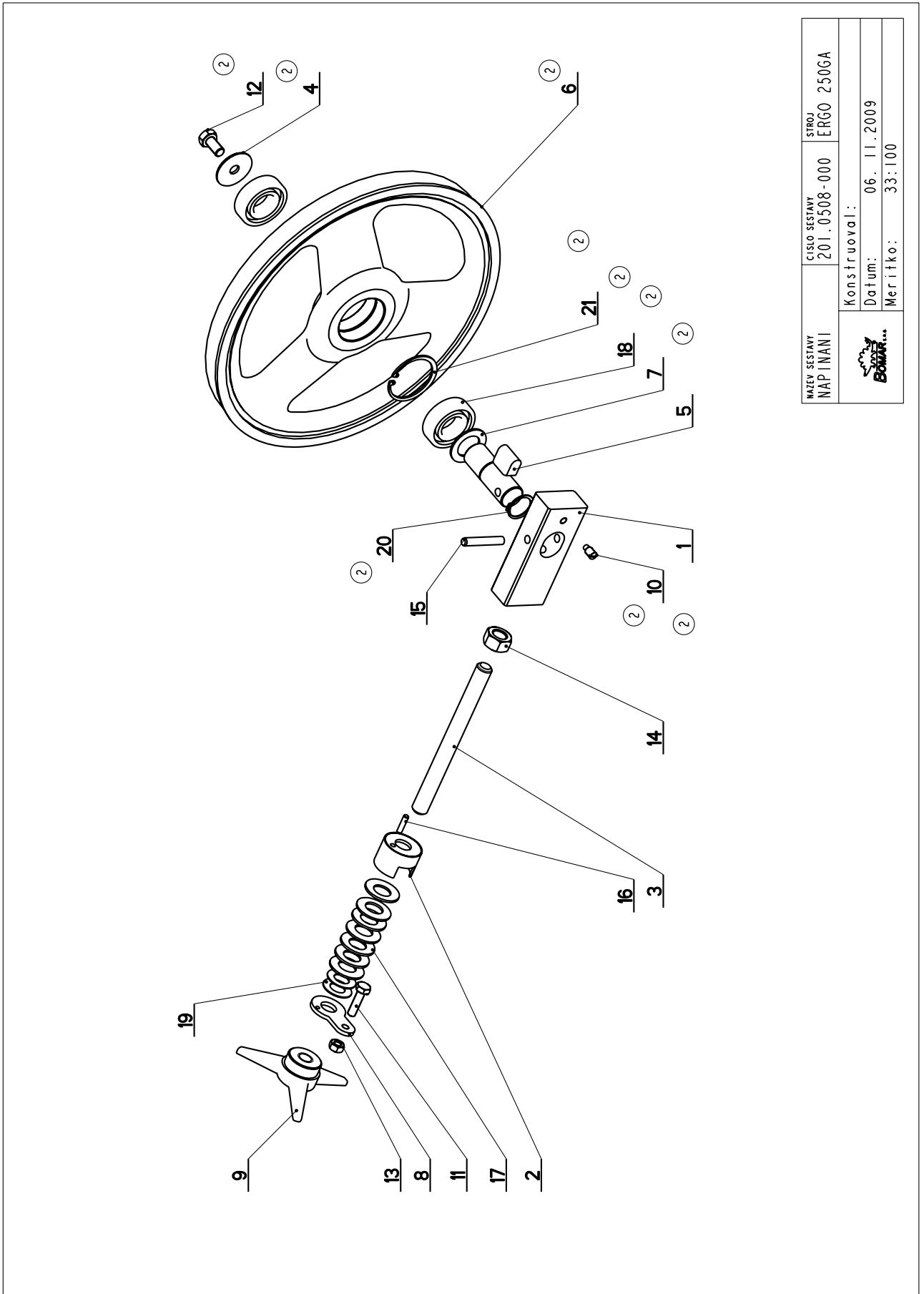

NAZEV SESTAVY NAPÍNÁNÍ	ČÍSLO SESTAVY 201.0508-000	STROJ ERGO 250GA
Konstruoval:		
Datum: 06. 11.2009		
Meritko: 33:100		

7.22. Kusovník / Stückliste / Piece list –
Napínání / Spannung / Tensioning

Císlo Sestavy 201.0508-000		Ver. 0		Název sestavy NAPÍNÁNÍ / TENSIONING / SPANNUNG	
Pož.	Objednací číslo	Ver.	Název položky	Rozměr	Ks
1	30.0104-002	0	HRANOL / BLOCK / PRISMA	HR 50x 30	1
2	30.0104-004	2	DRŽAK / HOLDER / HALTER		1
3	30.0303-005	0	SROUB / BOLT / SCHRAUBE	M16	1
4	30.0505-011 (2)	0	PODLOŽKA / WASHER / UNTERLEGSCHETBE	TYC 40	1
5	30.0508-004 (2)	0	CEP NAPÍNÁNÍ / TENSIONING LUG / SPANNUNGSBOLZEN		1
6	30.0508-701 (2)	4	KOLO NAPÍNÁNÍ / TENSIONING WHEEL / UMLENKRAD		1
7	30.0702-023 (2)	0	KROUZEK DISTANČNÍ / DISTANCE RING / DISTANZRING		1
8	30.0704-025	3	DRŽAK / HOLDER / HALTER	P 4x 36	1
9	31.0104-006	0	HVEZDICE / STAR WHEEL / STERN	PLAST	1
10	90.004.2D.008 (2)	0	STAV SR S CIP / ADJUSTMENT BOLT / STELLSCHRAUBE	SROUB M8X16	1
11	90.005.55.017	0	6 HR SROUB ZIN / 6 SIDED BOLT / SECHSKANTSCHRAUBE	SROUB M8X30	1
12	90.005.55.023	0	6 HR SROUB ZIN / 6 SIDED BOLT / SECHSKANTSCHRAUBE	SROUB M10X20	1
13	90.100.55.005	0	MATICE DIN 934 / NUT / MUTTER	MATICE - M8	1
14	90.100.55.008	0	MATICE DIN 934 / NUT / MUTTER	MATICE - M16	1
15	90.300.0Z.012	0	KOLÍK VALC. KAL. / PIN / BOLZEN	KOLÍK 8X50	1
16	90.303.0Z.008	0	KOLÍK PRUŽNÝ / PIN / BOLZEN	KOLÍK 5X20	1
17	90.350.0Z.002	0	PRUŽINA TALIROVA / DISC SPRING / TELLERFEDER	35.5X18.3X2.0X2.8	7
18	95.001.018 (2)	0	LOŽISKO / BEARING / LAGER	6205 ZRS	2
19	95.750.001	0	KROUZEK KU / KU RING / KU-RING	16x1	2
20	95.800.012	0	KROUZEK POJIST.VNEJS / OUTSIDE SAFETY RING / SICHERUNGSRING AUßEN	POJISTINY KROUZEK 25	1
21	95.801.009 (2)	0	SEGR DIRA / INSIDE SAFETY RING / SICHERUNGSRING INNEN	POJISTINY KROUZEK 52	1

① ZMENA 30.0702-023 NA 30.0508-006, 0508-701 NA 0508-102, 0508-004 NA 0508-007, 0104-002 NA 0508-008, 95.001.018 NA 95.001.036
0505-011 NA 0508-002, 95.801.009 NA 95.801.010 14.5.2004 URICAR

2. ZRUŠENA ZMENA I. NEBYLA REALIZOVANA. 266/ZM255 28.7.2008 SLEZACKOVA

7.23. Vedení pásu / Sägebandführung / Belt guide

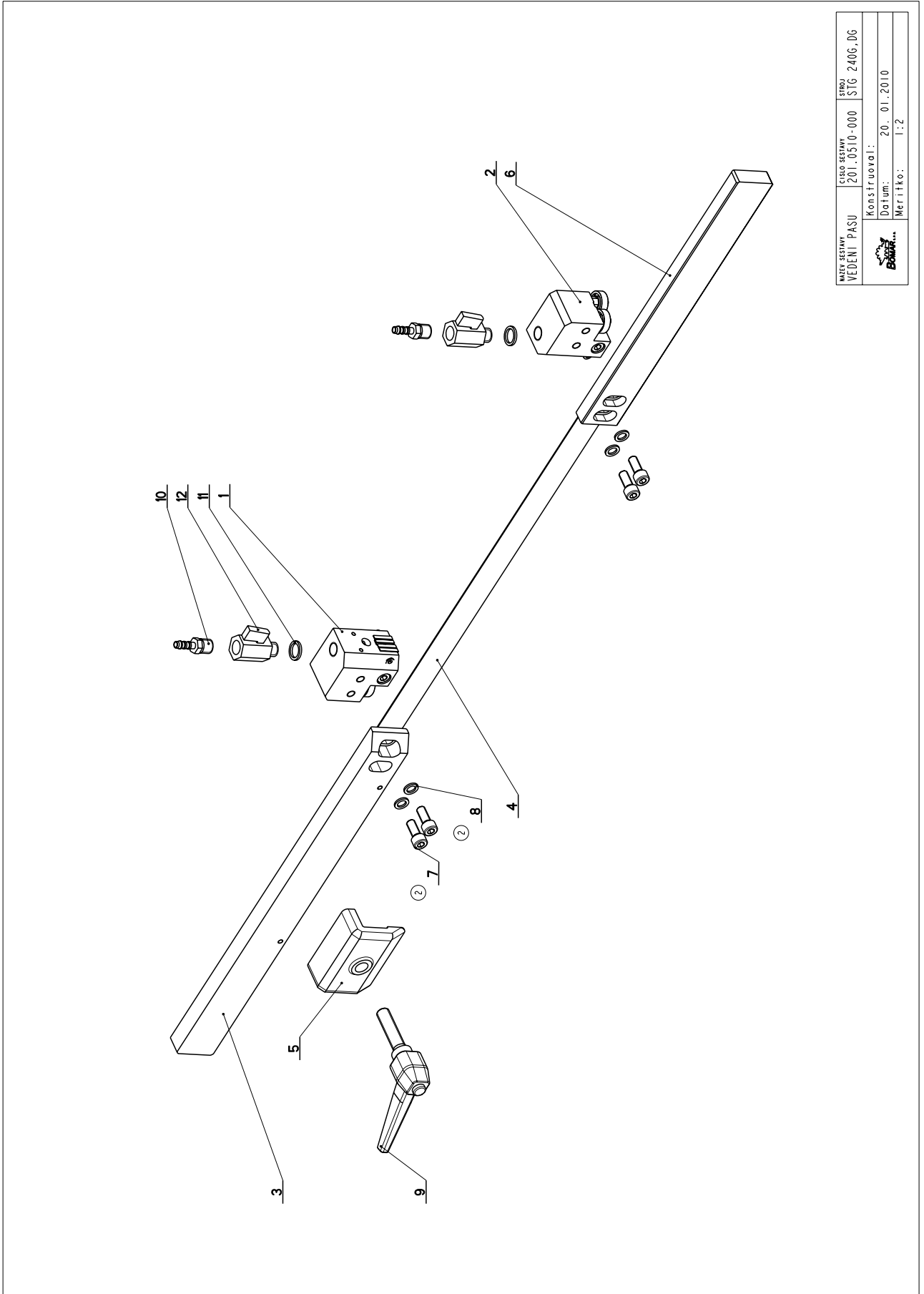

NAZEV ŠESTAVY VEDENÍ PÁSU	CÍSOVÝ ŠESTAVY 201_0510-000	STROJ STG 240G_JG
Konstruoval:		Datum: 20. 01. 2010
Merilko:		1:2

7.24. Kusovník / Stückliste / Piece list –
Vedení pásu / Sägebandführung / Belt guide

Cislo Sestavy 201.0510-000		Název sestavy VEDENÍ PÁSU/BELT GUIDE/SÄGEBANDFÜHRUNG			
Poz.	Objednací číslo	Ver.	Název položky	Rozměr	Ks
1	201.0110-100	0	KOSTKA VODICÍ / LEAD CUBE / FÜHRUNGSKLOTZ		1
2	201.0110-200	1	KOSTKA VODICÍ / LEAD CUBE / FÜHRUNGSKLOTZ		1
3	30.0104-015	4	LISTA / TRIM / LEISTE	TYC 40x20	1
4	30.0504-961	0	PAS PÍLOVÝ / SAW BELT / SÄGEBAND	2910x25(7)x0.90	1
5	30.0704-010	3	UPÍNKA / FASTENER / SPANNEISEN	ODLITEK	1
6	30.0704-014	4	LISTA / TRIM / LEISTE	TYC 40x15	1
7	90.001.25.032	0	SROUB IMBUS / ALLEN HEAD BOLT / IMBUSSCHRAUBE	8x20	4
8	90.163.00.002	2	PODLOŽKA / WASHER / UNTERLEGSCHLEIBE	PODLOŽKA 8	4
9	94.008.009	0	PAKA UPÍNACÍ / ATTACHMENT LEVER / SPANNHEBEL	M12	1
10	94.202.002	0	REDUKCE / REDUCTION / ADAPTOR / REDUKTION	REDUKCE 6/R1/4"	2
11	96.080.001	0	TESNĚNÍ / SEALING / DICHTUNG	17.8x13.5x2	2
12	99.260.001	0	VENTIL / VALVE / VENTIL	VENTIL KULOVÝ	2

1. dopl. kol. kuzel .6x20,6x26, 13.4.04 Stastný
2. PR ID. 4x PODLOŽKA NORDLOCK M8 90.163.00.002, ZRUS. 4x SROUB M8x16 A NAHR. SROUBEM M8x20. 161/ZMI48 14.5.2008 SLEZACKOVA

7.25. Vodící kostka / Führungsklotz / Guiding cube - 1

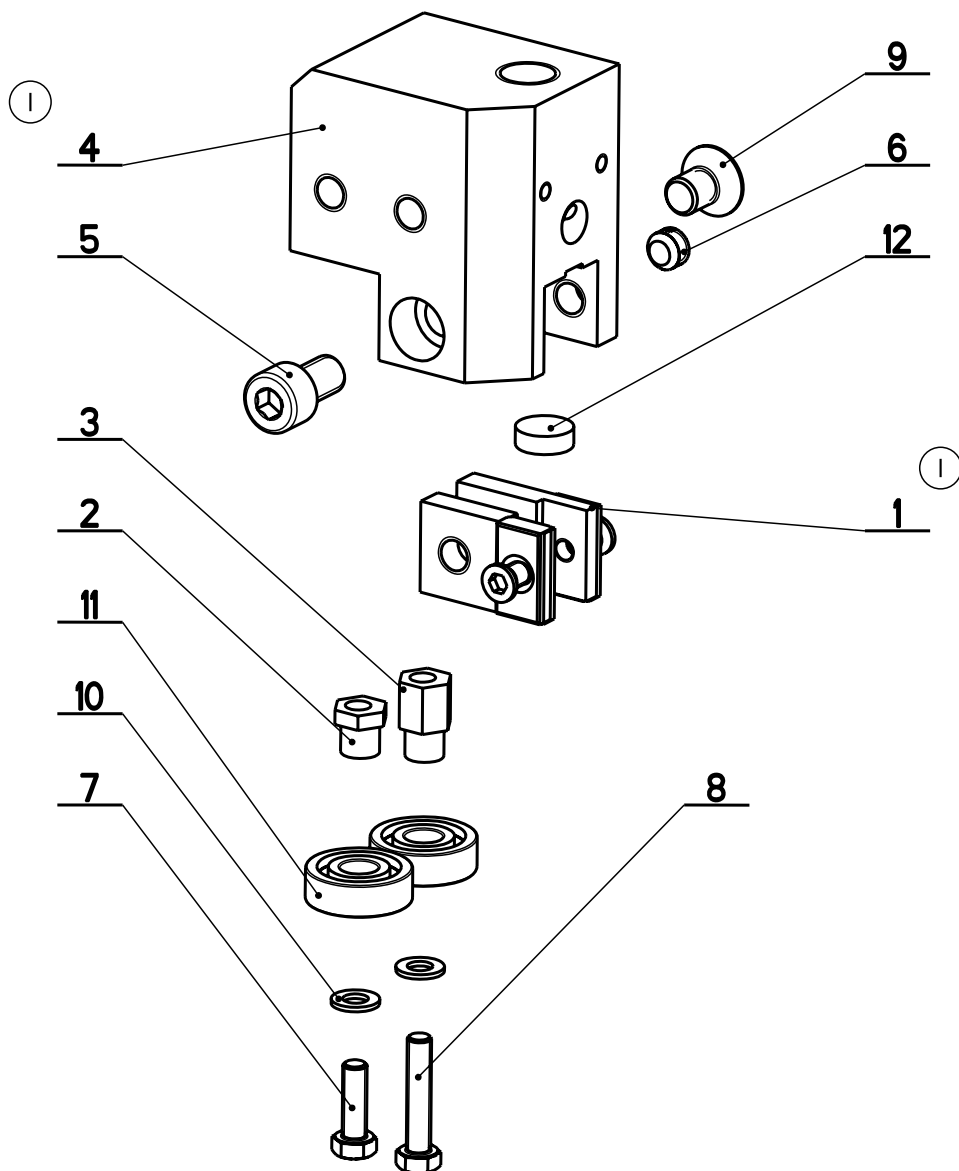

NAZEV SESTAVY KOSTKA VODICI	CISLO SESTAVY 201.0110-100	STROJ STG-240
	Konstruoval:	
	Datum: 06. 11. 2009	
	Meritko: 4:5	

7.26. Kusovník / Stückliste / Piece list –
Vodící kostka / Führungsklotz / Guiding cube – 1

Číslo sestavy 201.0110-100		Název sestavy KOSTKA VODICI / LEAD CUBE / FÜHRUNGSKLOTZ			
Poz.	Objednávací číslo	Verf.	Název položky	Rozměr	Ks
1	201.0104-021	0	DRZAK / HOLDER / HALTER		2
2	30.0104-018	0	EXCENTR / CAM / EXZENTER	SK10	1
3	30.0104-019	0	EXCENTR / CAM / EXZENTER	SK10	1
4	30.0104-032	0	KOSTKA VODICI / LEAD CUBE / FÜHRUNGSKLOTZ	TYC 60x40	1
5	90.001.55.082	0	SROUB IMBUS ZINEK / ALLEN HEAD BOLT / IMBUSSCHRAUBE	M8X14	1
6	90.002.20.009	0	STAVECI S KUŽEL / ADJUSTMENT BOLT / STELLSCHRAUBE	SROUB M8X6	1
7	90.005.55.003	0	6 HR SROUB ZIN / 6 SIDED BOLT / SECHSKANTSCHRAUBE	SROUB M5X16	1
8	90.005.55.005	0	6 HR SROUB ZIN / 6 SIDED BOLT / SECHSKANTSCHRAUBE	SROUB M5X25	1
9	90.011.27.007	0	SROUB ZAPUSTNY / COUNTERSINK BOLT / SEMISCHRAUBE	SROUB M8X12	1
10	90.150.50.003	0	PODLOŽKA D1M125 / WASHER / UNTERLEGSCHIBE	PODLOŽKA 5,3	2
11	95.001.001	0	KUL. LOŽ. I RADE / BEARING / LAGER	608 2RS	2
12	99.040.002	0	TVRDOKOV / HARD METAL / HM-SEGMENT	d 12	1

I. ZRUSENA SOUC. 30.0104-020 A NAHR. 201.0104-021. 297/272 12.8.2008 KRPEC

7.27. Vodící kostka / Führungsklotz / Guiding cube - 2

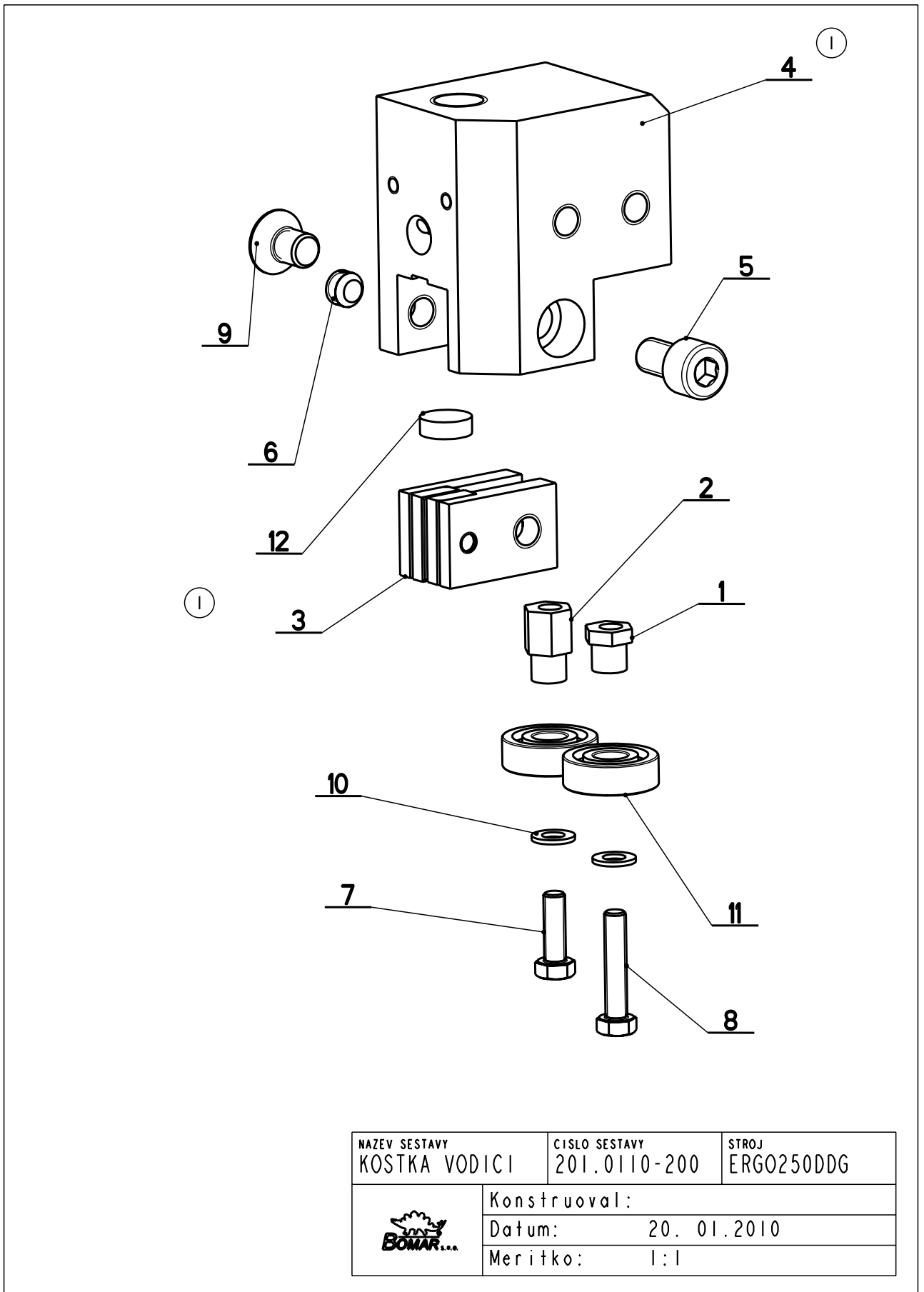

7.28. Kusovník / Stückliste / Piece list –
Vodící kostka / Führungsklotz / Guiding cube – 2

Císlo Sestavy 201.0110-200		Ver. 1		Název sestavy KOSTKA VODÍCI / LEAD CUBE / FÜHRUNGSKLOTZ	
Pož.	Objednávací číslo	Ver.	Název položky	Rozměr	Ks
1	30.0104-018	0	EXCENTR / CAM / EXZENTER	SK10	1
2	30.0104-019	0	EXCENTR / CAM / EXZENTER	SK10	1
3	30.0104-021	0	DRŽÁK / HOLDER / HALTER		2
4	30.0104-031	2	KOSTKA VODÍCI / LEAD CUBE / FÜHRUNGSKLOTZ	TYC 60x40	1
5	90.001.55.082	0	SROUB IMBUS / ALLEN HEAD BOLT / IMBUSSCHRAUBE	M8x14	1
6	90.002.20.009	0	SROUB STAVECI / ADJUSTMENT BOLT / STELLSCHRAUBE	SROUB M8x6	1
7	90.005.55.003	0	SROUB 6HRANNÝ / 6 SIDED BOLT / SECHSKANTSCHRAUBE	SROUB M5x16	1
8	90.005.55.005	0	SROUB 6HRANNÝ / 6 SIDED BOLT / SECHSKANTSCHRAUBE	SROUB M5x25	1
9	90.011.27.007	0	SROUB ZAPUSTNÝ / COUNTERSINK BOLT / SENKSCHRAUBE	SROUB M8x12	1
10	90.150.50.003	0	PODLOŽKA / WASHER / UNTERLEGSCHEIBE	PODLOŽKA 5,3	2
11	95.001.001	0	LOŽISKO / BEARING / LAGER	608 2RS	2
12	99.040.002	0	TVRDOKOV / HARD METAL / HM-SEGMENT	d 12	1

I ZRUS. SOUCAST 30.0104-020 NAHRAZENA SOUC. 30.0104-021, ZRUS. SOUCAST 30.0104-016 NAHRAZENA SOUC. 30.0104-031.
297/ZM272 12.8.2008 KRPEC

7.29. Kartáč / Bürste / Brush

Cislo Sestavy 201.0704-100		Ver. 0		Název sestavy KARTAC/BRUSH/BÜRSTE	
Poz.	Objednací číslo	Ver.	Název položky	Rozměr	Ks
1	30.0104-022	0	DRZAK / HOLDER / HALTER	HR 16x16	1
2	30.0704-029	0	HRÍDEL / SHAFT / WELLE	d 14	1
3	31.0704-031	0	KARTAC / BRUSH / BÜRSTE		1
4	90.150.50.006	0	PODLOŽKA DIN125 / WASHER / UNTERLEGSCHIBE	PODLOŽKA 10,5	1
5	90.100.55.006	0	MATICE / NUT / MUTTER	MATICE _ M10	1
6	90.150.50.004	0	PODLOŽKA / WASHER / UNTERLEGSCHIBE	PODLOŽKA 6,4	1
7	95.800.001	0	KROUZEK POJIST.VNEJS / OUTSIDE SAFETY RING / SICHERUNGSRING AUBEN	POJISTNY KROUZEK 6	1
8	90.001.25.019	0	SROUB IMBUS CERNY / ALLEN HEAD BOLT / IMBUSSCHRAUBE	M6x25	1

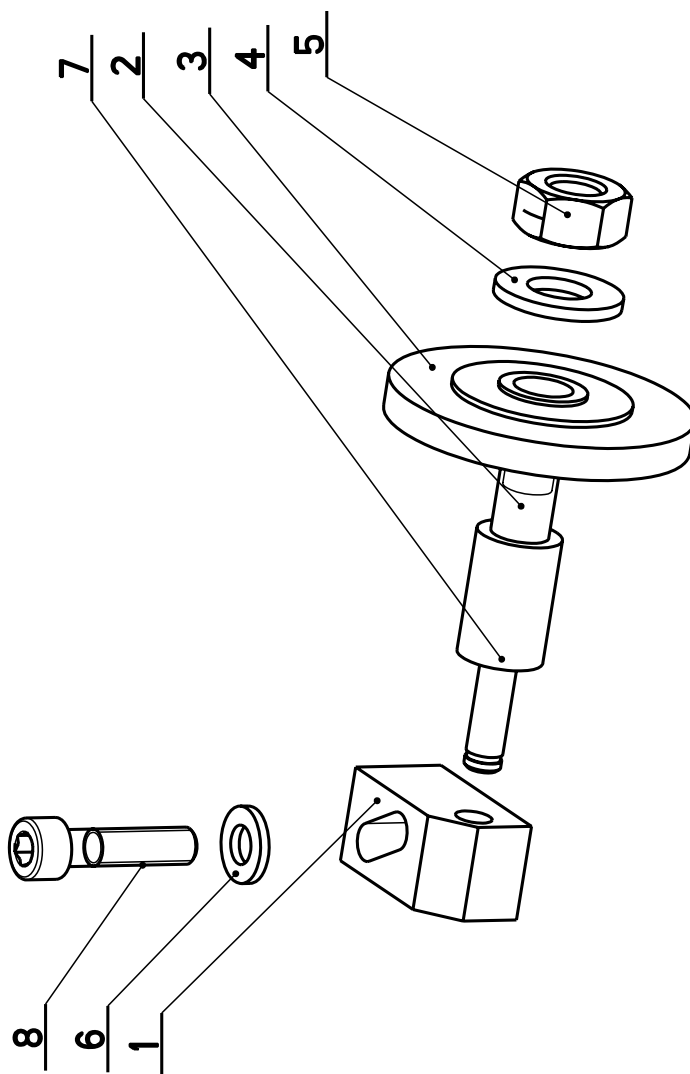

7.30. Pružina / Feder / Spring

Cislo Sestavy 201.0514-750		Ver. 0	Nazev sestavy PRUZINA/SPRING/FEDER		
Poz.	Objednaci cislo	Ver.	Nazev polozky	Rozmer	Ks
1	30.0502-720	2	TAHLO / GUY ROD / ZUGSTANGE	TYC 30x5	1
2	30.0504-050	1	TYC / POLE / STANGE	TYC 20	1
3	31.0502-719	1	PRUZINA / SPRING / FEDER	7.1x56.5x194.7x14.5	1

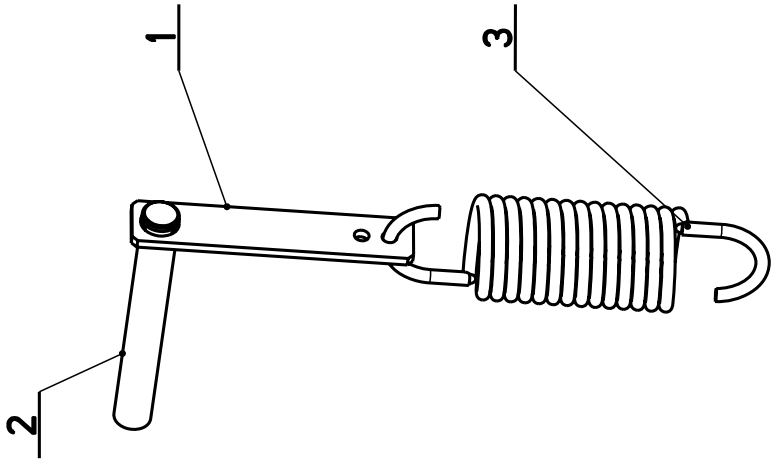

Cislo Sestavy/Number of assembly/Nummer der Baugruppe; Verze (Ver.)/Version/Version; Nazev sestavy/Assembly title/Name der Baugruppe; Pozice (Poz.)/Position/Position;	
Objednaci cislo/Purchase order number/Bestellnummer; Nazev polozky/Volume title/Name der Position; Rozmer/Stock size/Abmessung	