

BOMAR

Operating Instructions for Band Saw

ergonomic 290.250 DGA – 230V



Before transporting and using the machine, please read the instructions thoroughly!

Serial number:



Service and Information

In case of technical difficulties or spare parts order, please contact your dealer:

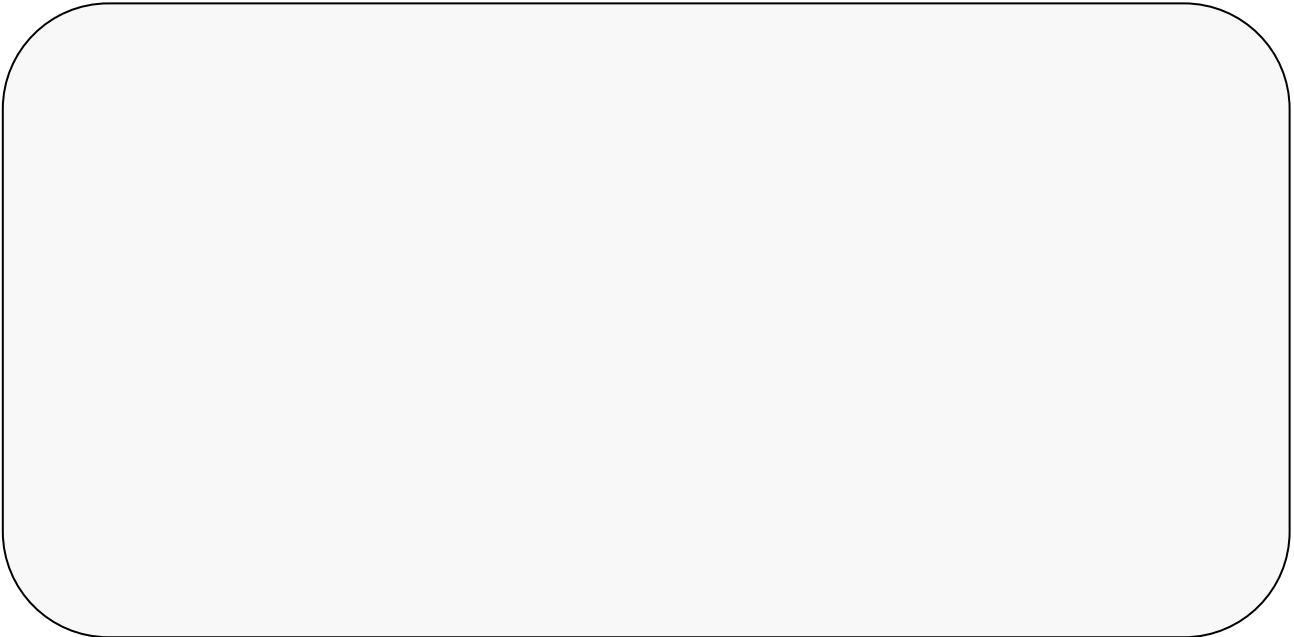

Or contact Bomar, spol. s r.o. directly:

BOMAR, spol. s r.o.
Těžební 1236/1
62700 Brno
CZECH REPUBLIC

Telephone: +420 – 533 426 100
x: +420 – 533 426 109

e-mail: info@bomar.cz
WWW: <http://www.bomar.cz>

We are available Mondays to Fridays from 7⁰⁰ to 16⁰⁰.

Content

1. INTRODUCTION	7
2. BAND SAW USING	7
3. TECHNICAL DATA.....	8
4. SAFETY NOTES	9
4.1. GENERAL	9
4.2. PROTECTIVE SUIT AND PERSONAL SAFETY.....	9
4.3. SAFETY NOTES FOR MACHINE OPERATOR	10
4.4. SAFETY NOTES FOR THE SERVICING AND REPAIRS	11
4.5. SAFETY MACHINE ACCESSORIES.....	11
5. TRANSPORTATION AND STOCKING	13
5.1. CONDITIONS FOR TRANSPORTATION AND STOCKING	13
5.2. SAFETY NOTES	13
5.3. TRANSPORT AND STOCKING PREPARATIONS	14
5.4. TRANSPORT AND STOCKING.....	14
6. ACTIVATION	15
6.1. MACHINE WORKING CONDITIONS.....	15
6.2. MACHINE INSTALLING AND LEVELLING	15
6.3. ELECTRICAL CONNECTION	15
6.4. FILLING OF THE COOLING SYSTEM.....	17
6.5. COOLANT DEVICE INSPECTION	18
6.6. CHIPS DISPOSAL	18
7. CHECK MACHINE FUNCTIONS.....	20
8. MATERIAL INSERTION.....	21
8.1. SAFETY NOTES	21
8.2. HANDLING EQUIPMENT SELECTION	21
8.3. MATERIAL INSERTION	21
8.4. BUNDLE MATERIAL CUTTING	22
9. BAND SAW ADJUSTING.....	23
9.1. SAFETY NOTES	23
9.2. OPTIMAL ADJUSTING OF THE GUIDE CUBES SPAN	23
9.3. SAW BEND CUTTING SPEED.	23
9.4. PRESSURE ADJUSTING TO THE CUT	24
10. MATERIAL REMOVING FROM THE BAND SAW.....	25
10.1. SAFETY NOTES	25
11. SELECTION AND REPLACEMENT OF THE SAW BAND	26
11.1. SAFETY NOTES	26
11.2. SAW BAND SIZE	26
11.3. SELECTION OF THE SAW BAND TOOTH SYSTEM:	26
11.4. SAW BAND RUNNING - IN	28
11.5. SAW BAND DISMANTLING.....	29

11.6.	SAW BAND INSTALLATION	30
11.7.	SAW BAND STRETCHING AND INSPECTION.....	31
11.7.1.	<i>Saw band stretching</i>	31
11.7.2.	<i>Saw band inspection</i>	31
12.	COOLING AGENTS AND CHIPS DISPOSAL.....	32
12.1.	SAFETY NOTES	32
12.2.	COOLING LIQUID PREPARATION	32
13.	GREASES AND OILS.....	33
13.1.	GEARBOX OILS.....	33
13.2.	HYDRAULIC OILS	34
13.3.	LUBRICANT GREASES	34
14.	SERVICE.....	35
14.1.	MACHINE CLEANING	35
14.2.	LUBRICATION.....	35
14.3.	COOLING LIQUID INSPECTION.....	35
14.4.	HYDRAULIC OIL LEVEL CHECK	36
15.	ADJUSTMENT	37
15.1.	HARD METAL GUIDES ADJUSTMENT	37
15.2.	GUIDE CUBE ADJUSTMENT	37
15.3.	SAW BAND RUN ADJUSTMENT ON STRETCHING WHEEL	38
15.4.	BRUSH ADJUSTMENT	39
15.5.	ADJUSTING THE LIMIT SWITCH OF THE SAW BAND STRETCHING	40
15.6.	SAW FRAME LOWER POSITION STOP ADJUSTMENT.....	40
15.7.	ADJUSTMENT OF THE LIMIT SWITCH OF SAW FRAME LOWER STOP POINT.....	41
15.8.	ADJUSTMENT OF A THROTTLE VALVE	42
16.	CONTROL PANEL	43
17.	MACHINE OPERATION.....	48
17.1.	MANUAL MODE	48
17.1.1.	<i>Presumptions</i>	48
17.1.2.	<i>Referencing the machine.</i>	48
17.1.3.	<i>The basic menu display.</i>	49
17.2.	STARTING IN MANUAL MODE	49
17.2.1.	<i>Angle orientation</i>	51
17.3.	SEMI-AUTOMATIC MODE	51
18.	BAND SAW SETTING	52
18.1.	HOW TO NAVIGATE THROUGH THE SELECTED MENU.....	53
18.2.	USER'S DATA MENU	53
18.3.	SERVICE MENU	54
18.4.	PRODUCTION MENU	56
18.4.1.	<i>Offsets for correct length</i>	57
18.5.	CROSS OVER REFERENCE POINT - MEASUREMENT	59
18.6.	FEEDERS TRAVEL LENGTH - MEASUREMENT	59
18.7.	SAVING THE INITIAL VALUES	60
18.8.	LOADING THE INITIAL VALUES.....	60
18.8.1.	<i>List of error messages</i>	60
19.	CUTTING RECORDS.....	61
19.1.	OUTAGE EVALUATION	61

19.2.	WORKING WITH TABLE	61
19.3.	SETTING VALUES FOR THE CUTTING PROGRAM	62
19.4.	EDITING TABLE FOR CUTTING RECORDS.	63
19.5.	PROGRAMS PROCEDURES.	65
19.5.1.	<i>Cutting records confirming</i>	67
20.	PREPARATION FOR AUTOMATIC CYCLE.....	68
20.1.	PROGRAM WAS INTERRUPTED	68
20.2.	SELECT THE WAY HOW TO START AUTOMATIC CYCLE.	69
20.2.1.	<i>Load material in vice automatically</i>	69
20.2.2.	<i>Cut off at the beginning of the material</i>	70
21.	AUTOMATIC CYCLE START.	71
21.1.	AUTOMATIC CYCLE DISPLAY.....	72
21.2.	AUTOMATIC CYCLE ATTENDANCE	72
21.2.1.	<i>Cycle suspension</i>	72
21.2.2.	<i>Cycle interruption</i>	73
21.3.	OUT OF MATERIAL	73
21.4.	END OF PROGRAM	73
21.5.	ELECTRICAL OUTAGE	74
21.5.1.	<i>Proceeding after electrical outage</i>	74
22.	WARNING MESSAGES	74
23.	WORN PIECES REPLACEMENT.....	82
23.1.	HARD METAL GUIDES REPLACEMENT	82
23.2.	ROUND BRUSH REPLACEMENT.....	82
23.3.	SAW BAND GUIDING ROLLERS REPLACEMENT	83
23.4.	STRETCHING WHEEL REPLACEMENT	84
23.5.	DRIVING WHEEL REPLACEMENT	86
23.6.	COOLING PUMP REPLACEMENT.....	87
24.	ROZMĚROVÉ SCHÉMA / AUFSTELLZEICHNUNG / INSTALLATION DIAGRAM	89
24.1.	ROZMĚROVÉ SCHÉMA / AUFSTELLZEICHNUNG / INSTALLATION DIAGRAM	89
25.	ELEKTRICKÁ SCHÉMATA / ELEKTROSCHEMAS / WIRING DIAGRAMS.....	90
25.1.	ELEKTRICKÉ SCHÉMA / ELEKTROSCHEMA / WIRING DIAGRAM 1	90
25.2.	ELEKTRICKÉ SCHÉMA / ELEKTROSCHEMA / WIRING DIAGRAM 2	91
25.3.	ELEKTRICKÉ SCHÉMA / ELEKTROSCHEMA / WIRING DIAGRAM 3	92
25.4.	ELEKTRICKÉ SCHÉMA / ELEKTROSCHEMA / WIRING DIAGRAM 4	93
25.5.	ELEKTRICKÉ SCHÉMA / ELEKTROSCHEMA / WIRING DIAGRAM 5	94
25.6.	ELEKTRICKÉ SCHÉMA / ELEKTROSCHEMA / WIRING DIAGRAM 6	95
25.7.	ELEKTRICKÉ SCHÉMA / ELEKTROSCHEMA / WIRING DIAGRAM 7	96
25.8.	ELEKTRICKÉ SCHÉMA / ELEKTROSCHEMA / WIRING DIAGRAM 8	97
25.9.	ELEKTRICKÉ SCHÉMA / ELEKTROSCHEMA / WIRING DIAGRAM 9	98
25.10.	ELEKTRICKÉ SCHÉMA / ELEKTROSCHEMA / WIRING DIAGRAM 10.....	99
25.11.	ELEKTRICKÉ SCHÉMA / ELEKTROSCHEMA / WIRING DIAGRAM 11.....	100
25.12.	ELEKTRICKÉ SCHÉMA / ELEKTROSCHEMA / WIRING DIAGRAM 12.....	101
25.13.	ELEKTRICKÉ SCHÉMA / ELEKTROSCHEMA / WIRING DIAGRAM 13.....	102
25.14.	ELEKTRICKÉ SCHÉMA / ELEKTROSCHEMA / WIRING DIAGRAM 14.....	103
25.15.	ELEKTRICKÉ SCHÉMA / ELEKTROSCHEMA / WIRING DIAGRAM 15.....	104
25.16.	ELEKTRICKÉ SCHÉMA / ELEKTROSCHEMA / WIRING DIAGRAM 16.....	105
25.17.	ELEKTRICKÉ SCHÉMA / ELEKTROSCHEMA / WIRING DIAGRAM 17.....	106
25.18.	ELEKTRICKÉ SCHÉMA / ELEKTROSCHEMA / WIRING DIAGRAM 18.....	107

26. HYDRAULICKÉ SCHÉMA / HYDRAULIKSCHEMA / HYDRAULIC DIAGRAM	109
27. VÝKRESY SESTAV PRO OBJEDNÁNÍ NÁHRADNÍCH DÍLŮ / ZEICHNUNGEN FÜR BESTELLUNG DER ERSATZTEILE / DRAWING ASSEMBLIES FOR SPARE PARTS ORDER	113
27.1. SKLUZ / RUTSCH / GLIDE	115
27.2. PODAVAČ / VORSCHUB / FEEDER	116
27.3. ODMĚŘOVÁNÍ RAMENE / RAHMENABMESUNG / ADMEASUREMENT OF ARM	120
27.4. SVĚŘÁK HLAVNÍ / HAUPTSCHRAUBSTOCK / MAIN VICE	122
27.5. POHON / ANTRIEB / DRIVE	124
27.6. KRYT / DECKEL / COVER.....	126
27.7. KONZOLA OTOČNÁ / DREHKONSOLE / TURNING CONSOLE	128
27.8. PANEL / PANEL / PANEL.....	130
27.9. PÁSOVÁ PILA / BANDSÄGE / BAND SAW	132
27.10. PODSTAVEC / UNTERGESTELL / PEDESTAL	134
27.11. VÁLEČKOVÁ TRAŤ / ROLLENBAHN / ROLL CONVEYOR	138
27.12. ZÁVORA OPTICKÁ / LICHTSPERRE / LASER BEAM.....	140
27.13. RAMENO A POHON / SÄGERAHMEN UND ANTRIEB / SAW BAND AND DRIVE - 251.038	142
27.14. NAPÍNÁNÍ PILOVÉHO PÁSU / SÄGEBANDSPANNUNG / SAW BAND STRETCHING	146
27.15. LEVÁ VODÍCÍ KOSTKA / LINKER FÜHRUNGSKLOTZ / LEFT GUIDING CUBE	148
27.16. PRAVÁ VODÍCÍ KOSTKA / RECHTER FÜHRUNGSKLOTZ / RIGHT GUIDING CUBE	150
27.17. KARTÁČEK / SPÄNBÜRSTE / BRUSH.....	152
28. TROUBLESHOOTING TABLE.....	154
28.1. MECHANICAL PROBLEMS	154
28.2. ELECTRIC AND HYDRAULIC PROBLEMS	156
29. SPECIAL ACCESSORY.....	158
29.1. VICE PRESSURE REGULATION	158
29.2. FREQUENCY CONVERTER	158
29.3. MICRONISER.....	158
29.4. TENZOMAT	158
DECLARATION OF CONFORMITY.....	159

24. Rozměrové schéma / Aufstellzeichnung / Installation diagram

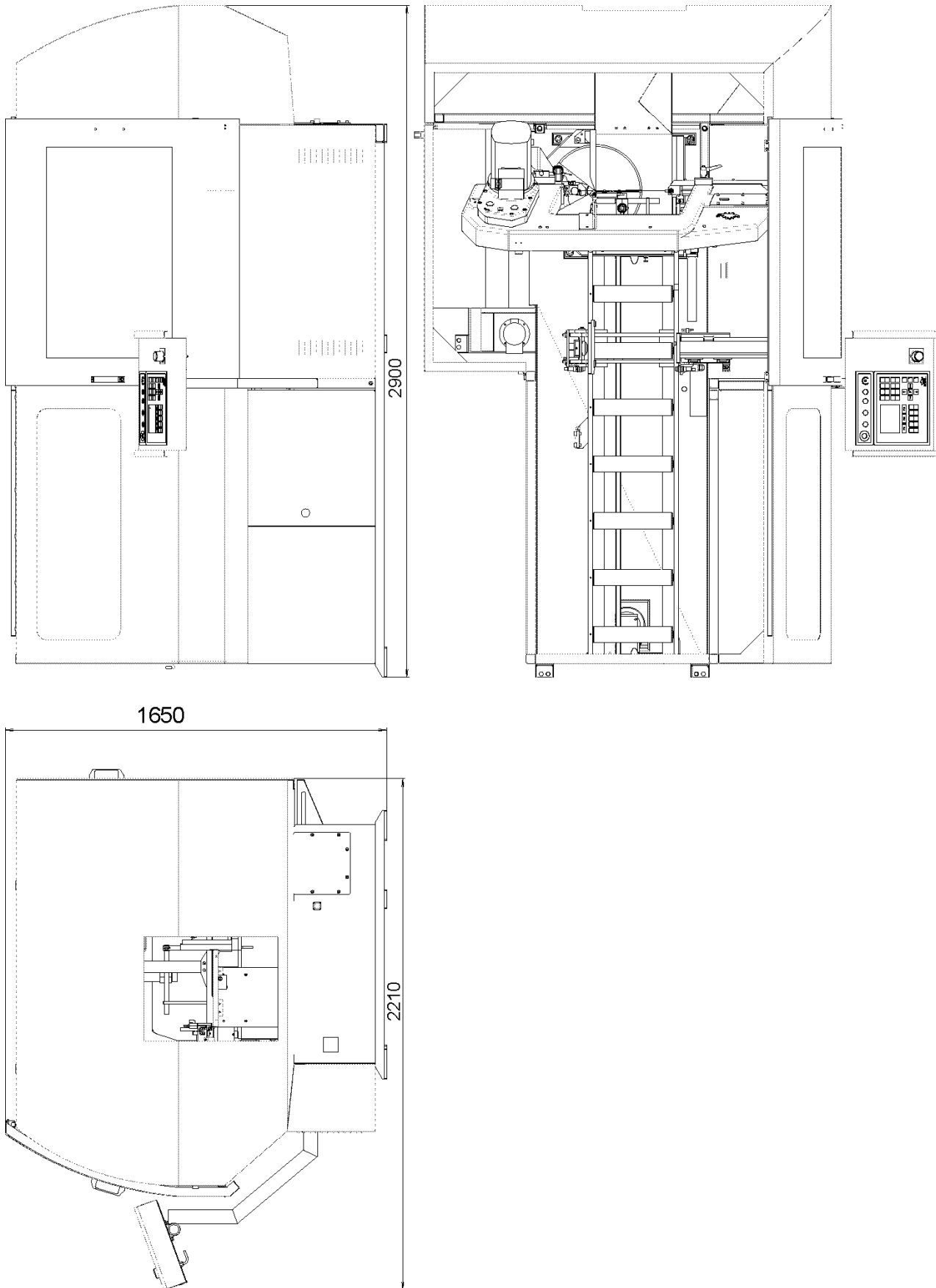

24.1. Rozměrové schéma / Aufstellzeichnung / Installation diagram

25. Elektrická schémata / Elektroschemas / Wiring diagrams

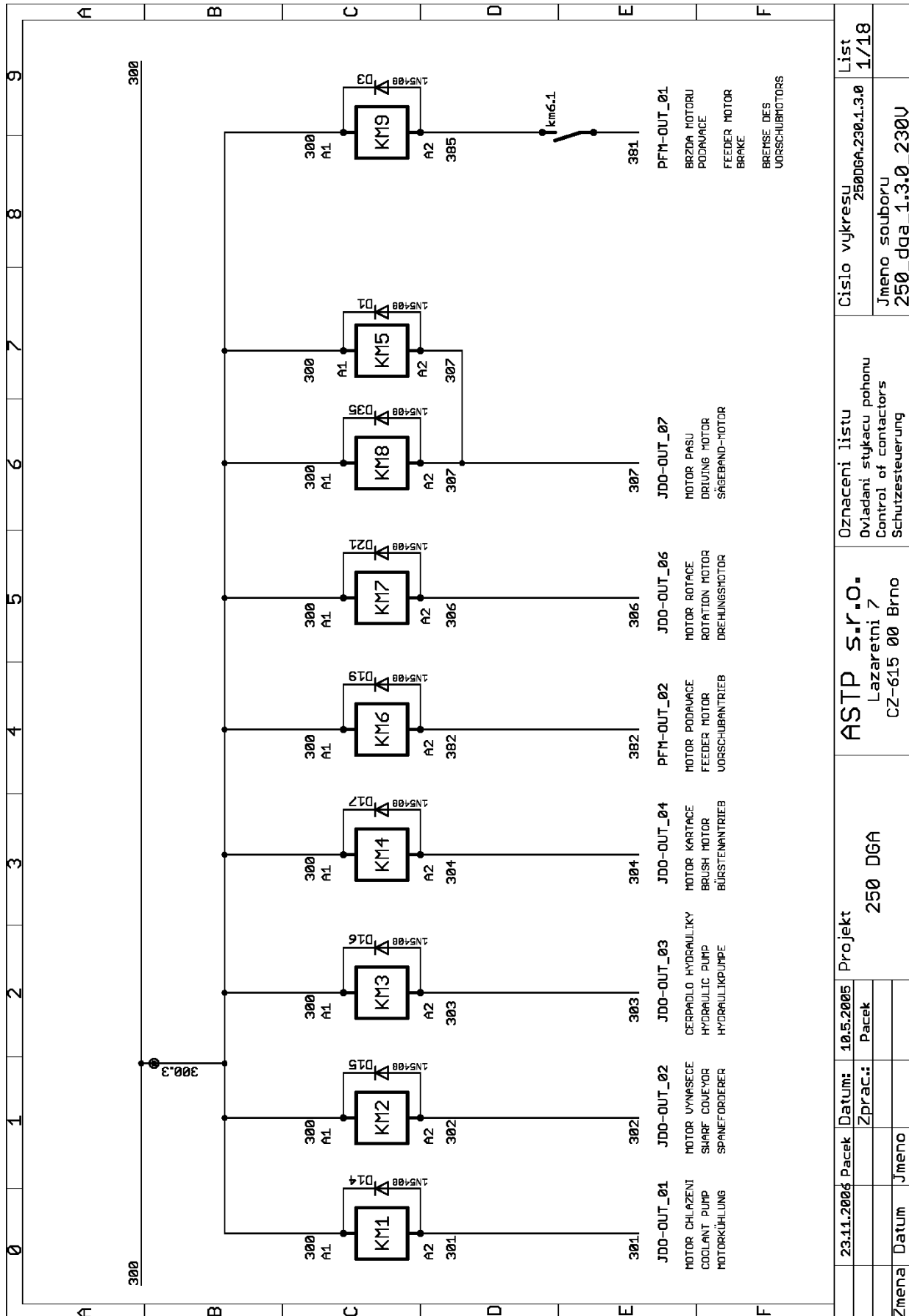

25.1. Elektrické schéma / Elektroschema / Wiring diagram 1

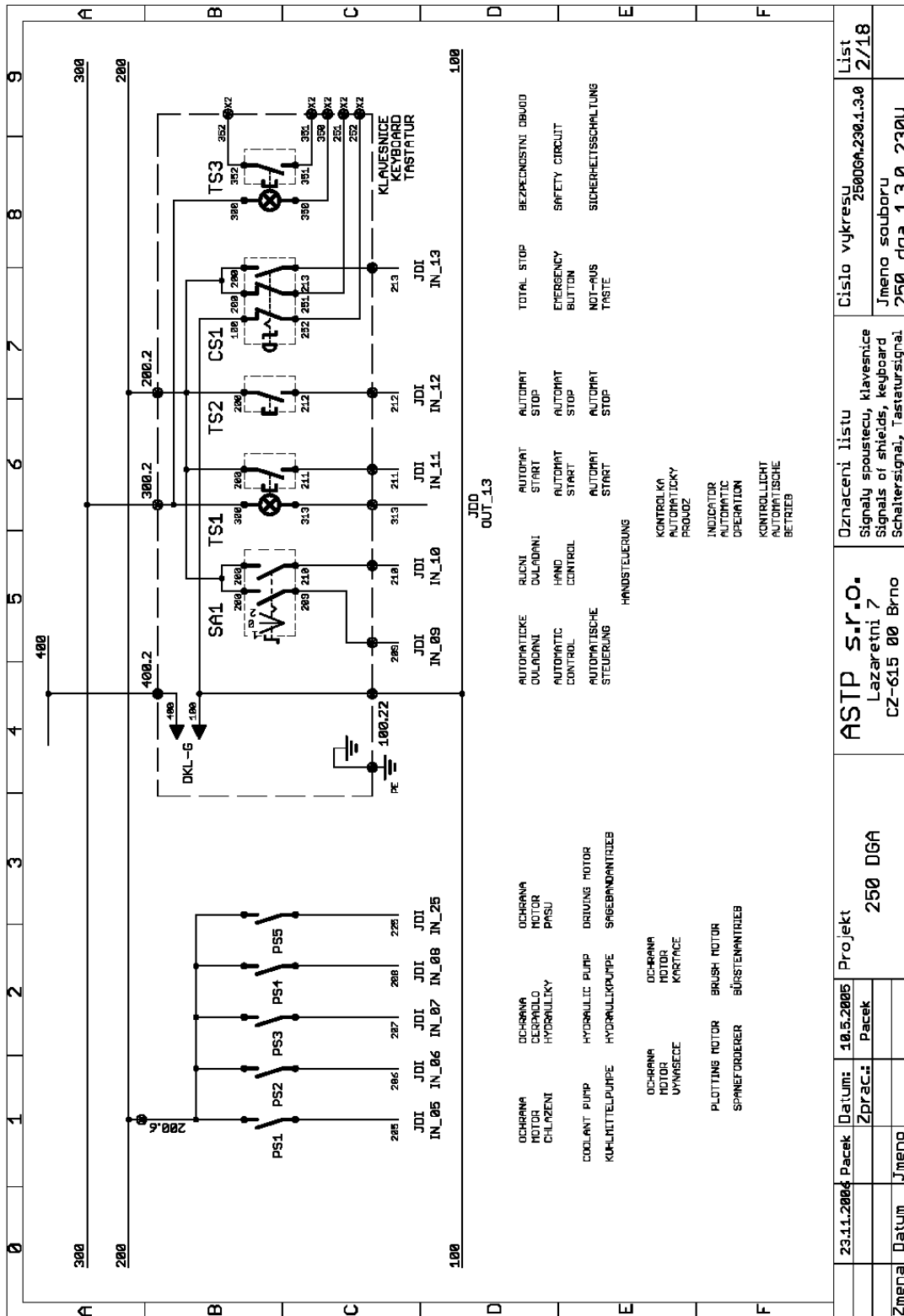

25.2. Elektrické schéma / Elektroschema / Wiring diagram 2

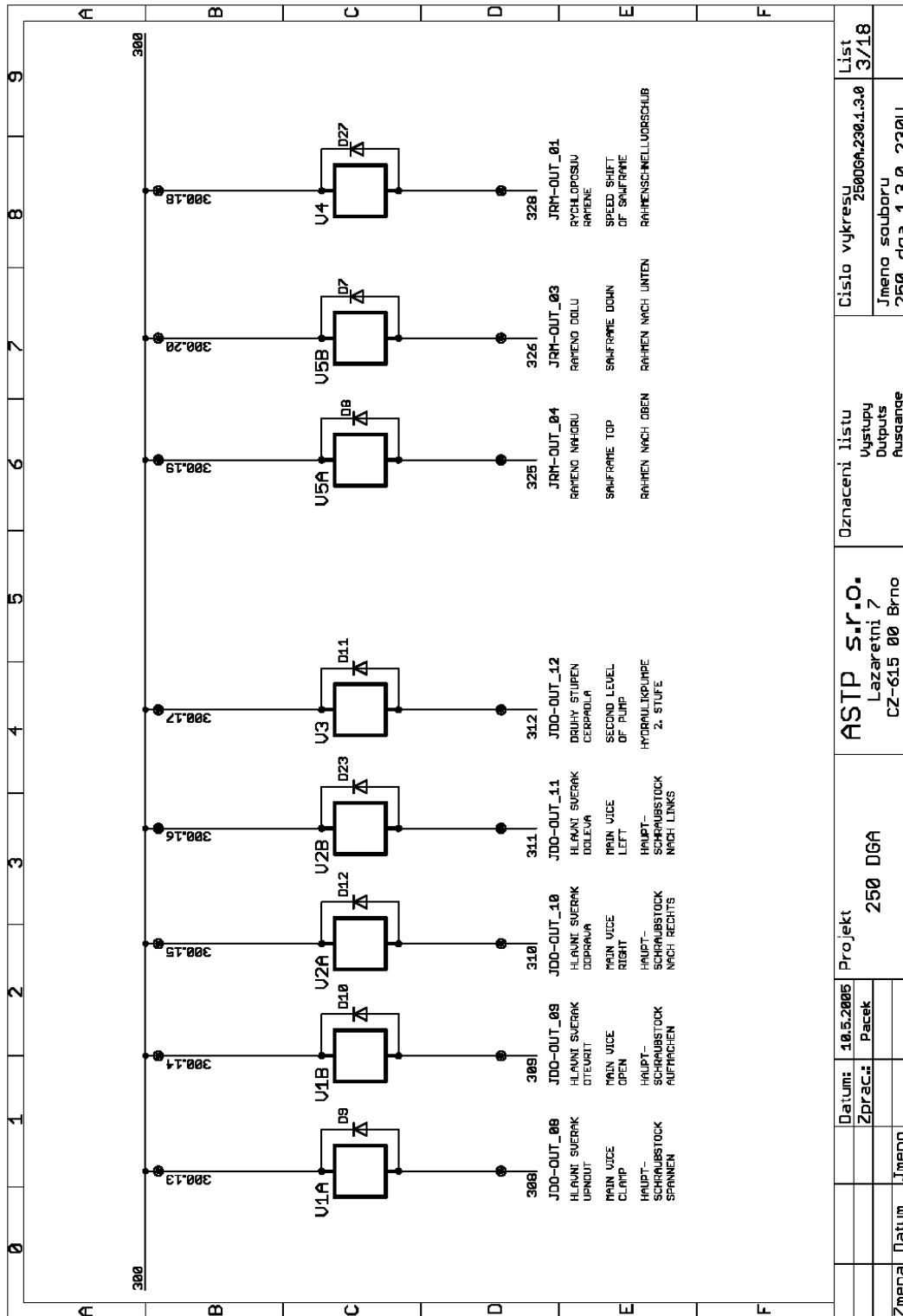

25.3. Elektrické schéma / Elektroschema / Wiring diagram 3

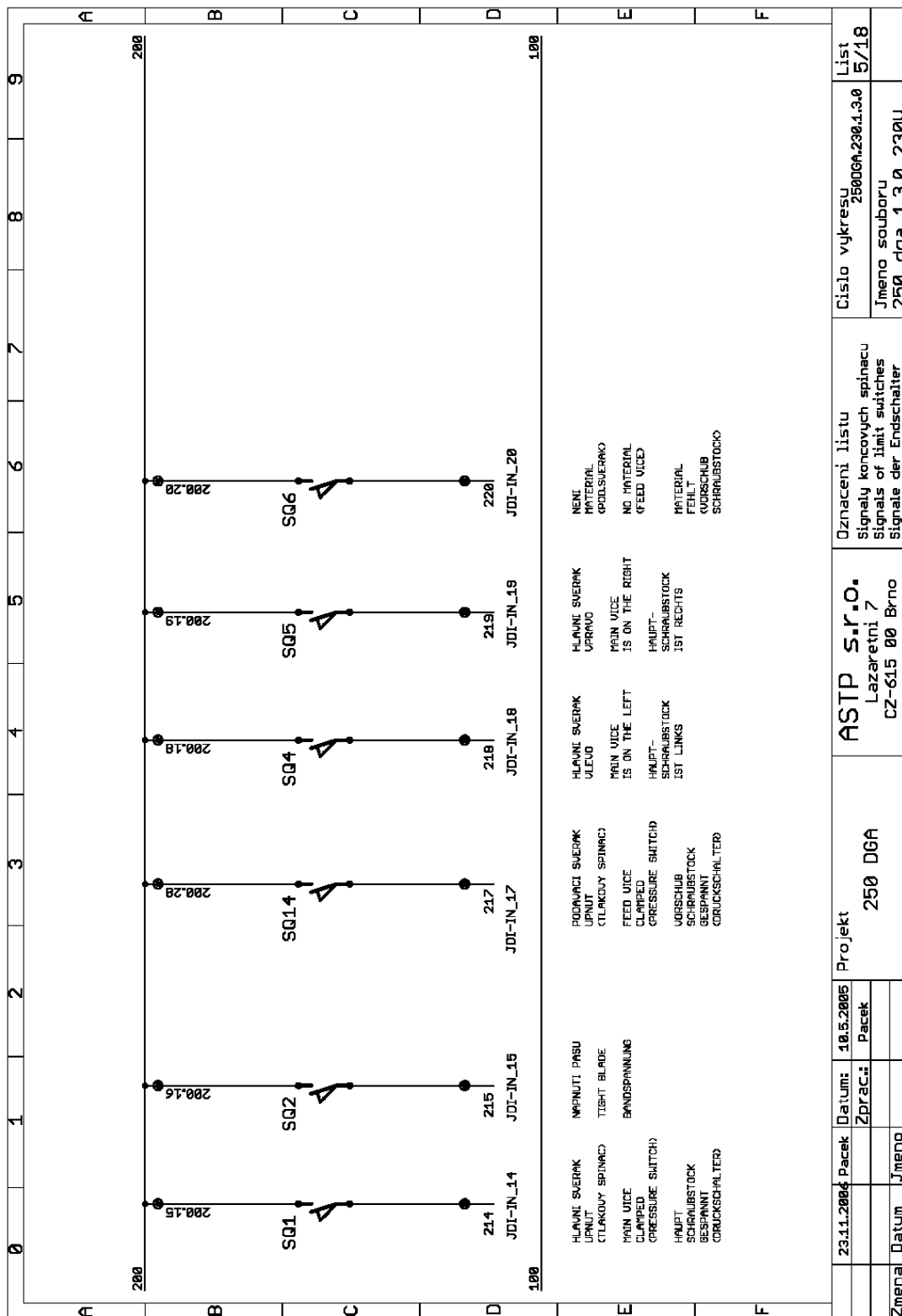

25.5. Elektrické schéma / Elektroschema / Wiring diagram 5

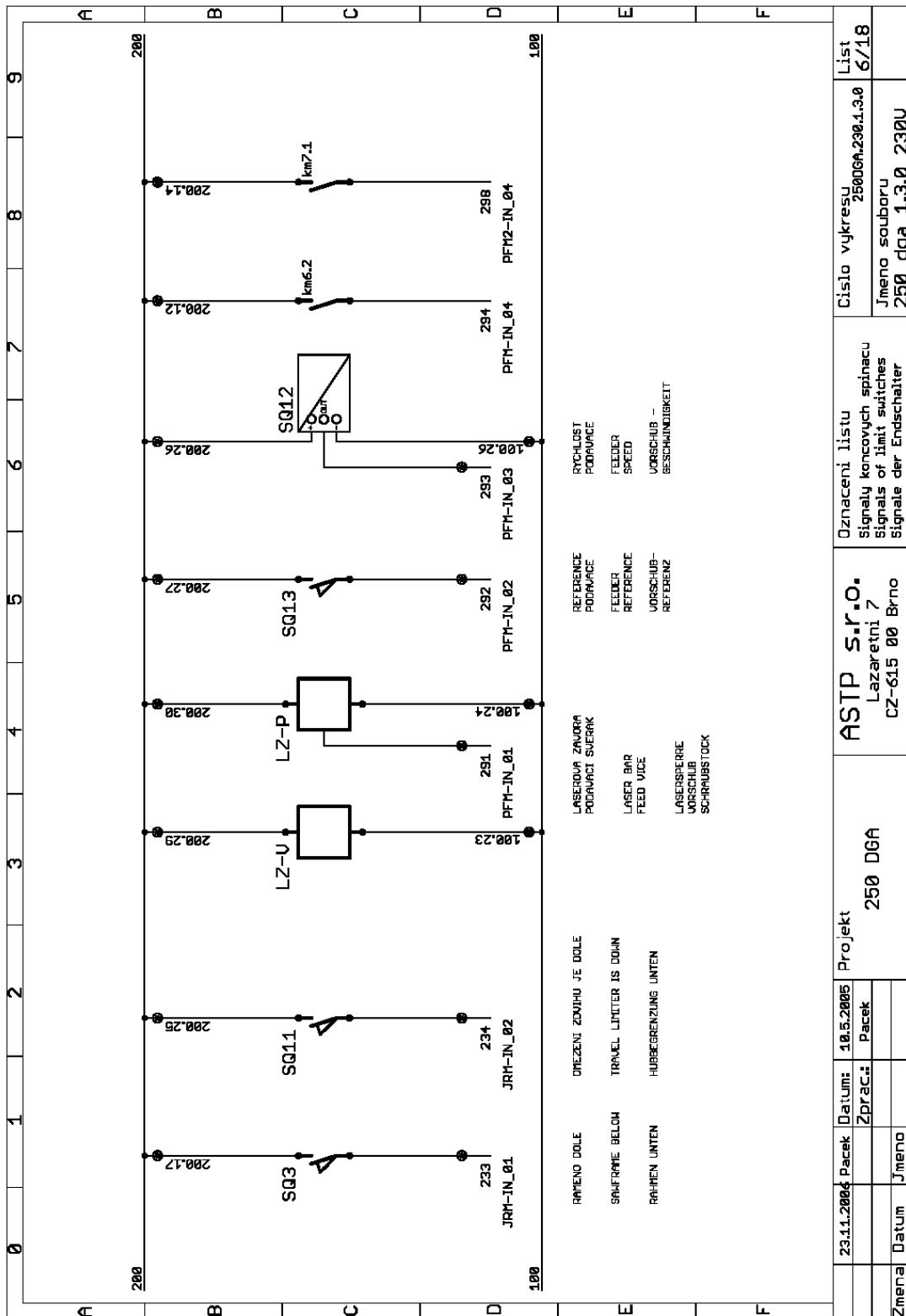

25.6. Elektrické schéma / Elektroschema / Wiring diagram 6

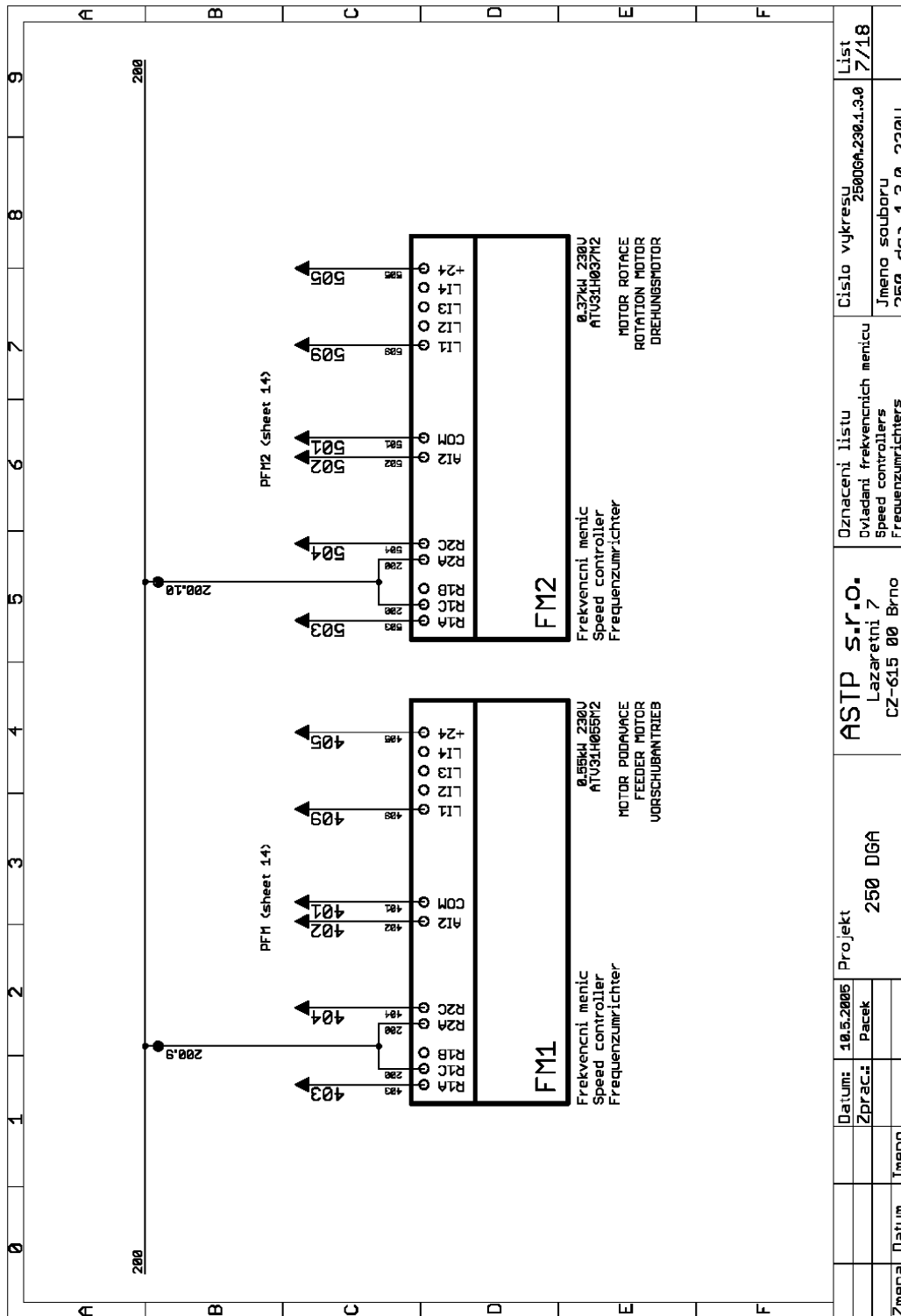

25.7. Elektrické schéma / Elektroschema / Wiring diagram 7

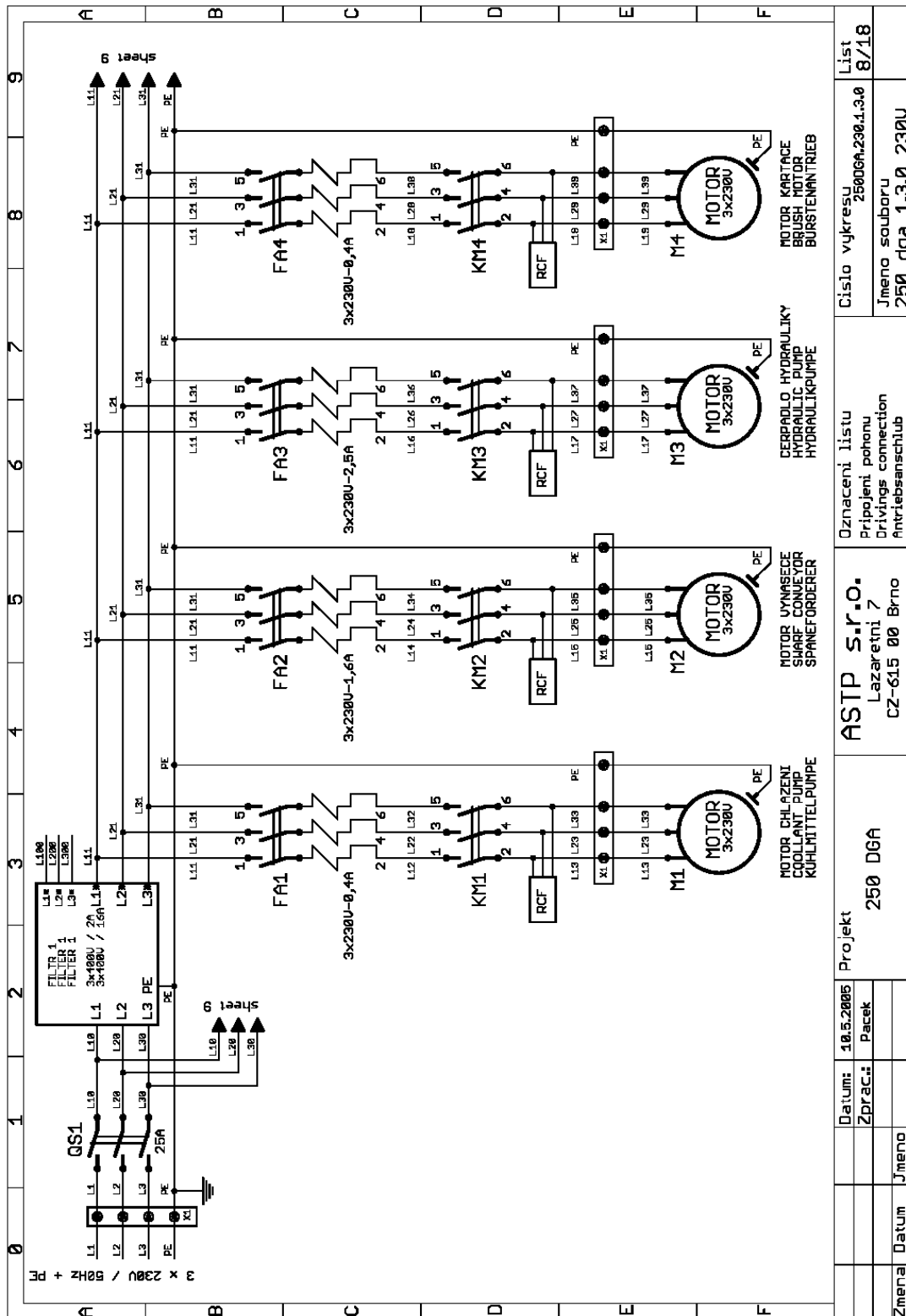

Zmena		Datum	Jmeno
Zprac:		Datum:	Projekt
Pacak		10.5.2005	250 DGA
			ASTP s.r.o. Lazaretni 7 CZ-615 00 Brno
			Oznaceni listu Pripojeni pohonu Drivings connection Antriebsanschluss
			Cislo vykresu 250DGA.230.1.3.0
			Jmeno souboru 250_dga_1.3.0_230V
			List 8/18

25.8. Elektrické schéma / Elektroschema / Wiring diagram 8

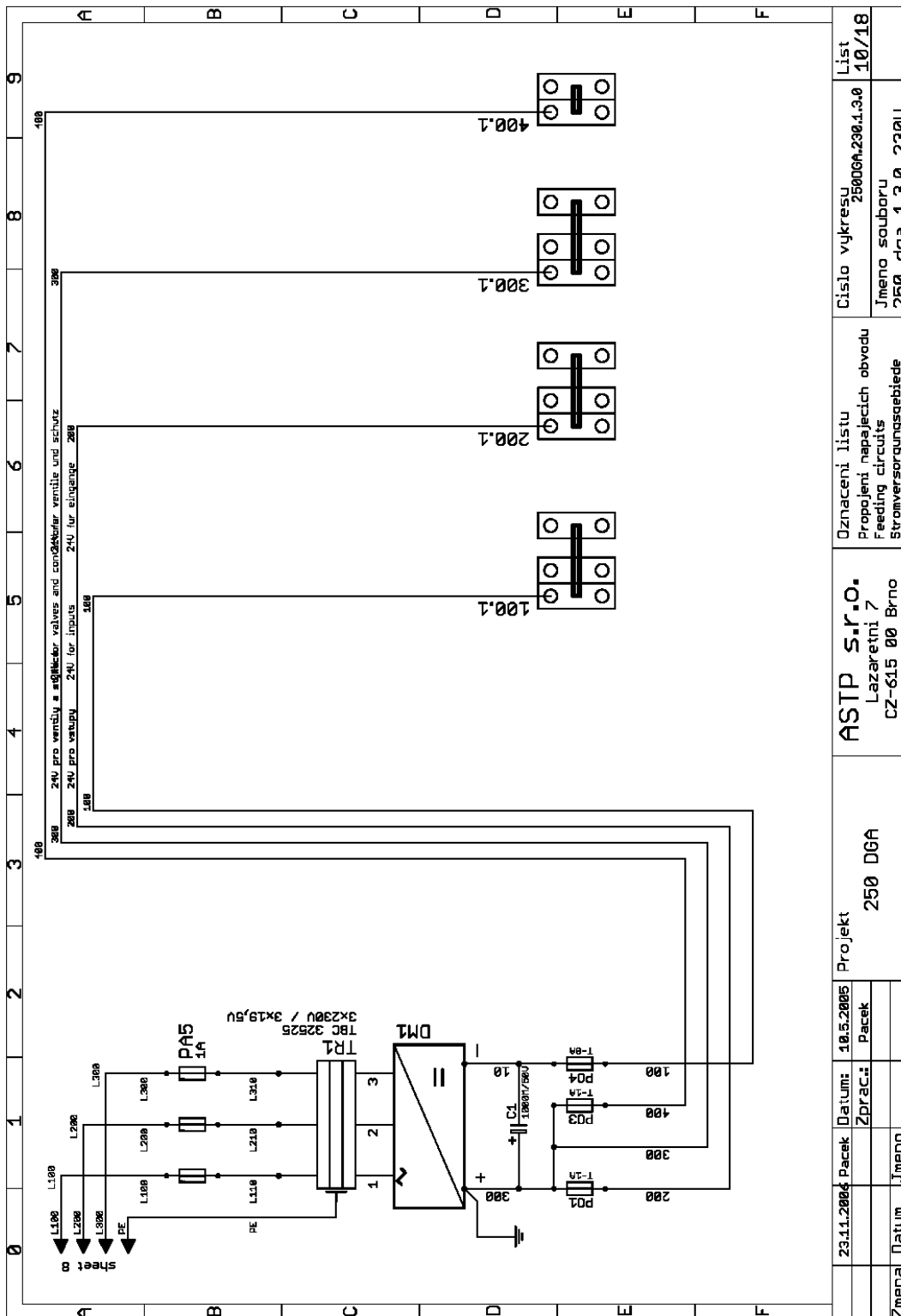

25.10. Elektrické schéma / Elektroschema / Wiring diagram 10

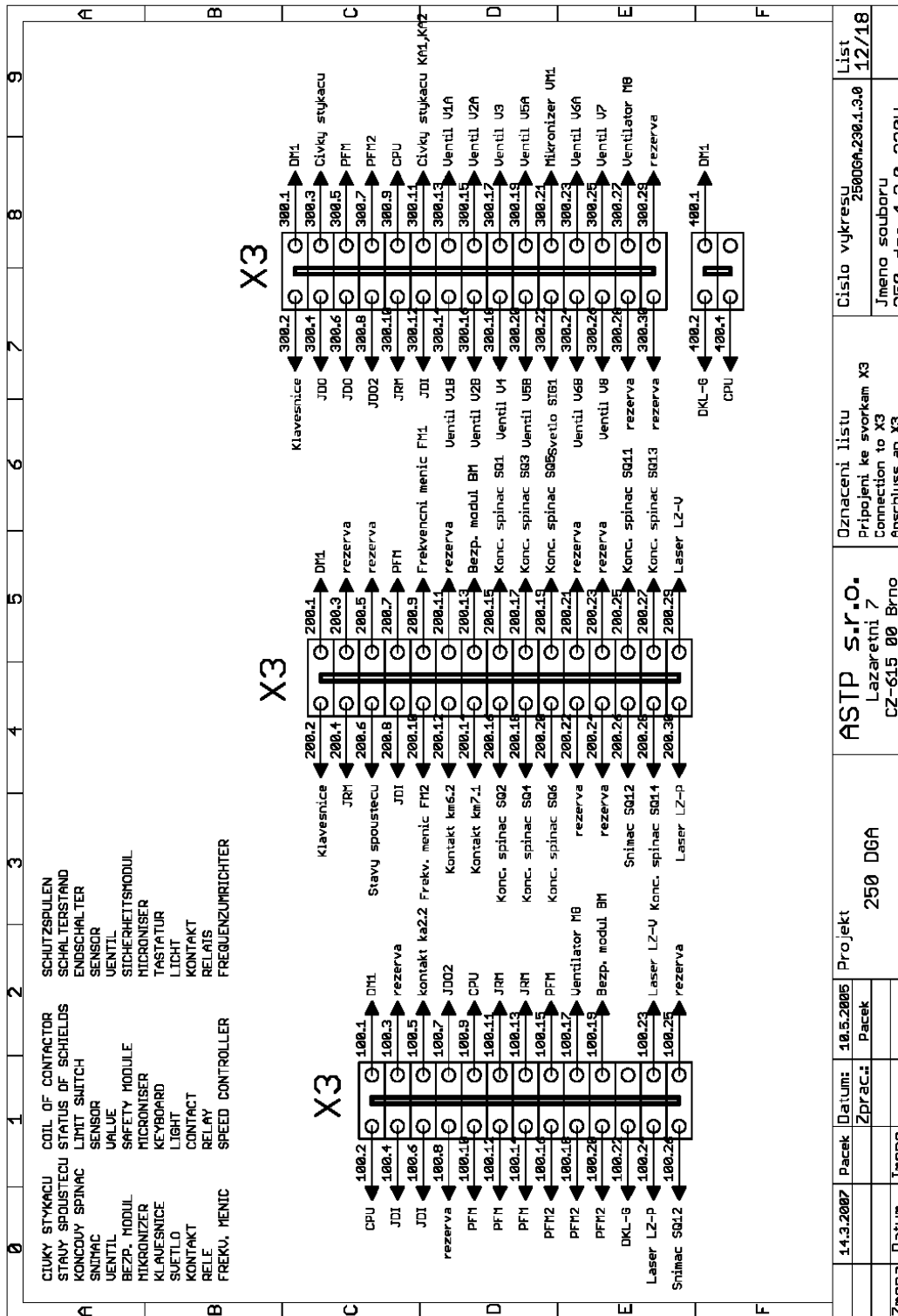

25.12. Elektrické schéma / Elektroschema / Wiring diagram 12

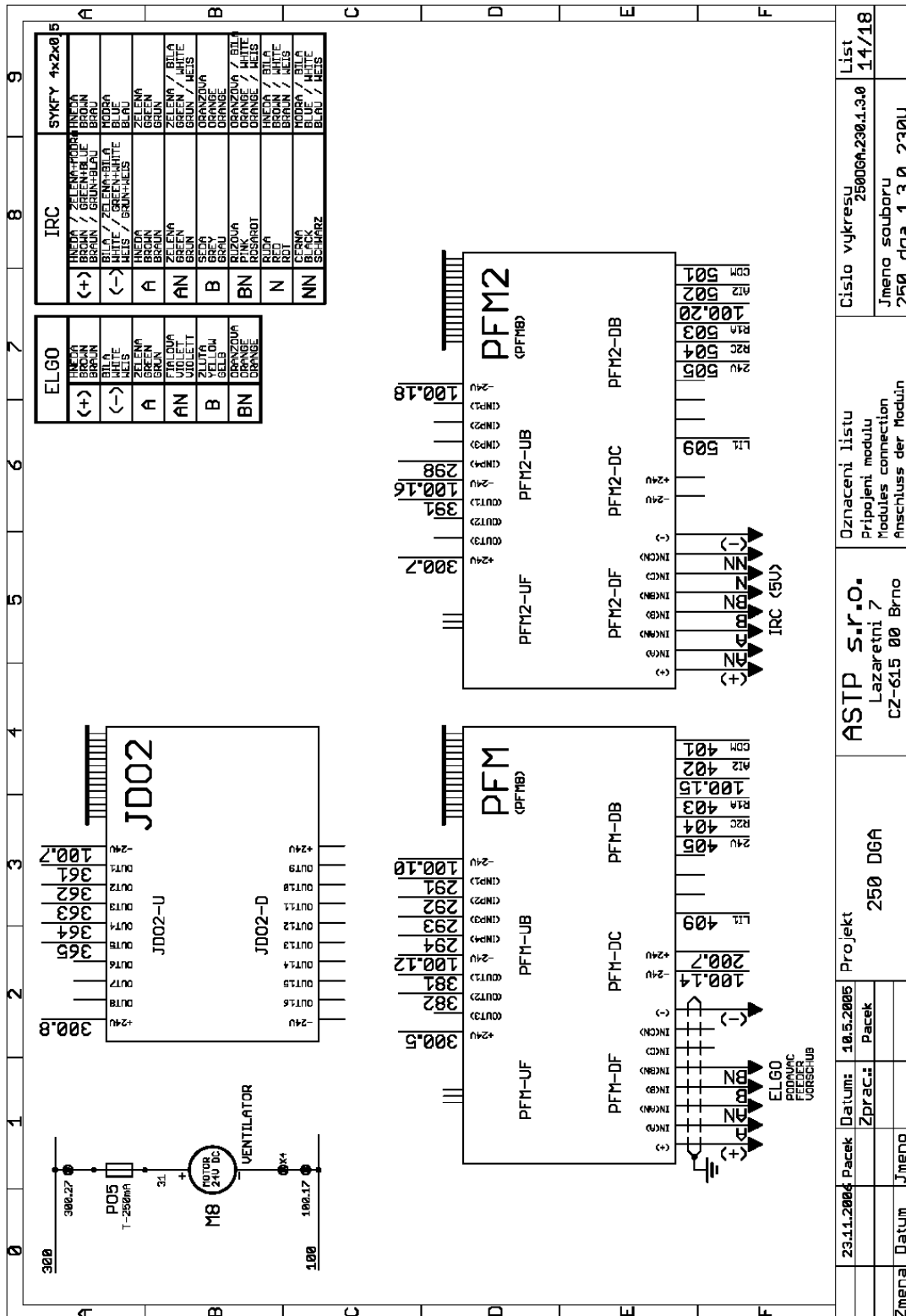

25.14. Elektrické schéma / Elektroschema / Wiring diagram 14

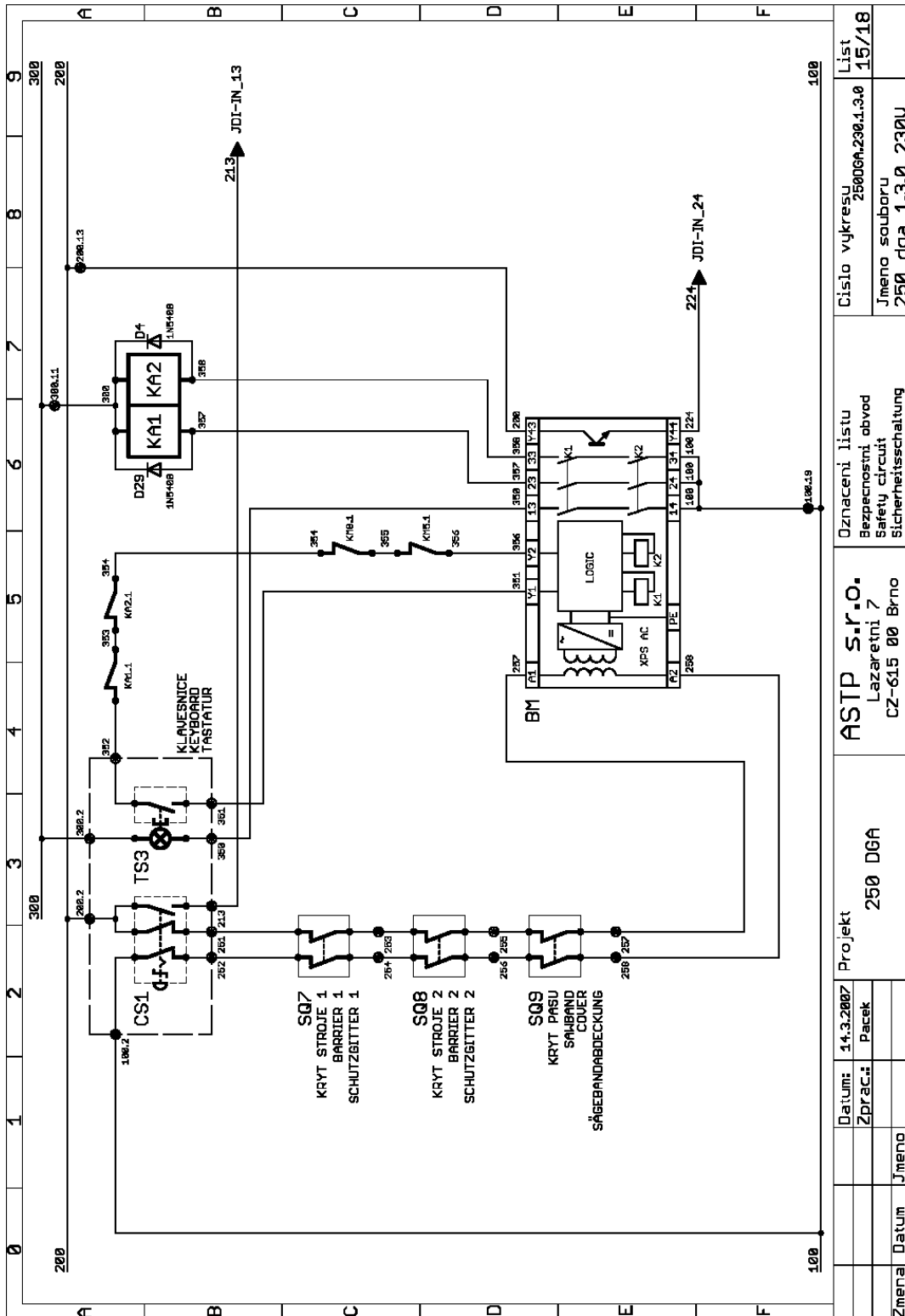

Změna	Datum	Jmeno	Datum	14.3.2007	Projekt	250 DGA	ASTP s.r.o. Lazaretni 7 CZ-615 00 Brno	Oznaceni listu Bezpečnostní obvod Safety circuit Sicherheitsschaltung	Cislo vykresu 25006A.230.1.3.0	List 15/18
									Jmeno souboru 250_dga_1.3.0_230U	

25.15. Elektrické schéma / Elektroschema / Wiring diagram 15

0	1	2	3	4	5	6	7	8	9
JDI - Signalizace stavu vstupu									
tlacitko uvolněno tlačitko stisknuto									
16									
15									
14									
13									
12									
11									
10									
9									
8									
7									
6									
5									
4									
3									
2									
1									
J002 - Signalizace stavu výstupu									
16									
15									
14									
13									
12									
11									
10									
9									
8									
7									
6									
5									
4									
3									
2									
1									
JRM - Signalizace stavu jednotky									
JRM - Signalizace stavu jednotky									
12									
11									
10									
9									
8									
7									
6									
5									
4									
3									
2									
1									
PFM - Signalizace stavu jednotky									
PFM - Signalizace stavu jednotky									
12									
11									
10									
9									
8									
7									
6									
5									
4									
3									
2									
1									

25.16. Elektrické schéma / Elektroschema / Wiring diagram 16

	0	1	2	3	4	5	6	7	8	9		
A	JDO - Output State Signalization											
	16											
	15											
	14											
	13											
	12											
	11											
	10											
	9											
	8											
	7											
	6											
	5											
	4											
	3											
	2											
1												
B	JDI - Input State Signalization											
	16											
	15											
	14											
	13											
	12											
	11											
	10											
	9											
	8											
	7											
	6											
	5											
	4											
	3											
	2											
1												
C	JDM - Input State Signalization											
	16											
	15											
	14											
	13											
	12											
	11											
	10											
	9											
	8											
	7											
	6											
	5											
	4											
	3											
	2											
1												
D	JDM2 - Output State Signalization											
	16											
	15											
	14											
	13											
	12											
	11											
	10											
	9											
	8											
	7											
	6											
	5											
	4											
	3											
	2											
1												
E	JRM - Unit State Signalization											
	12											
	11											
	10											
	9											
	8											
	7											
	6											
	5											
	4											
	3											
	2											
	1											
	F	JRM2 - Unit State Signalization										
		12										
		11										
10												
9												
8												
7												
6												
5												
4												
3												
2												
1												
A		PFM - Unit State Signalization										
		12										
		11										
	10											
	9											
	8											
	7											
	6											
	5											
	4											
	3											
	2											
	1											
	B	PFM2 - Unit State Signalization										
		12										
		11										
10												
9												
8												
7												
6												
5												
4												
3												
2												
1												
C		PFM2 - Unit State Signalization										
		12										
		11										
	10											
	9											
	8											
	7											
	6											
	5											
	4											
	3											
	2											
	1											
	D	PFM2 - Unit State Signalization										
		12										
		11										
10												
9												
8												
7												
6												
5												
4												
3												
2												
1												
E		PFM2 - Unit State Signalization										
		12										
		11										
	10											
	9											
	8											
	7											
	6											
	5											
	4											
	3											
	2											
	1											
	F	PFM2 - Unit State Signalization										
		12										
		11										
10												
9												
8												
7												
6												
5												
4												
3												
2												
1												
G		ASTP S.R.O. - Project Data										
		16										
		15										
	14											
	13											
	12											
	11											
	10											
	9											
	8											
	7											
	6											
	5											
	4											
	3											
	2											
1												

25.17. Elektrické schéma / Elektroschema / Wiring diagram 17

26. Hydraulické schéma / Hydraulikschema / Hydraulic diagram

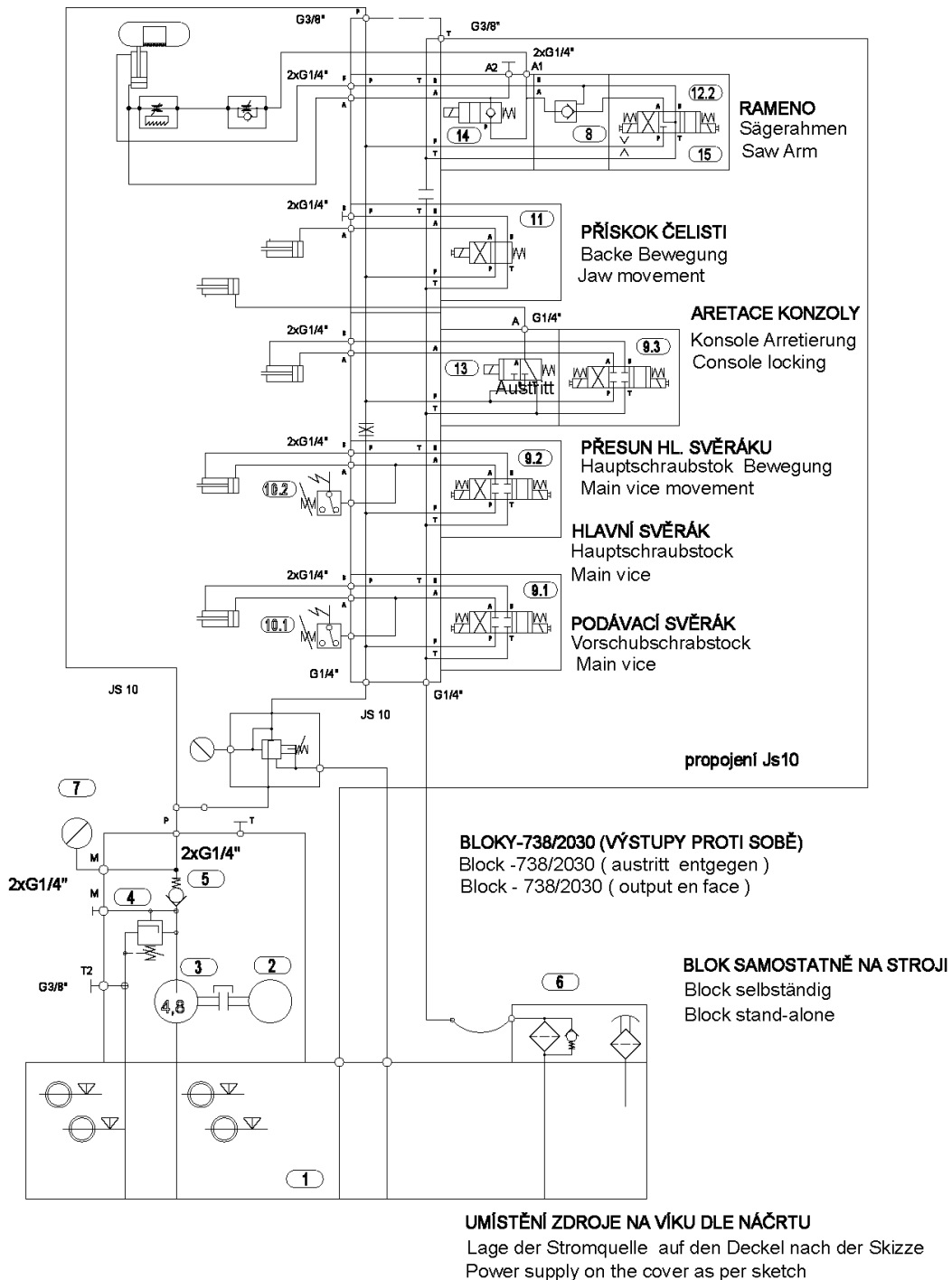

Základní technické parametry
Technische Spezifikation
Technical specification

Q ₁	6.3	dm ³ min ⁻¹	Rev.	1390	min ⁻¹
P _{max}	4	MPa	P	0.55	kW

Hydraulické schéma	870-1229	Schéma / Schema / Diagram	8701922A.DWG
Hydraulikschema		Datum / Datum / Date	20.10.2005
Hydraulic Diagram			

Poz.	Název položky		ks
Pos.	Bezeichnung		Menge
Pos.	Item		Pcs.
1	Nádrž / Behälter / Tank	30 dm special (750/7264)	1
2	Elektromotor / Elektromotor / Electromotor	MA-AL80 400/230V -50Hz	1
3	Hydrogenerátor / Hydraulikaggregat / Hydrogenerator	P2-4.8L 66017 4.8cub./rev.	1
4	Jednosměrný ventil / Einwegventil / One-way valve	VJO1-06/SG-1	1
5	Přepouštěcí ventil / Bypassventil / By pass valve	VPP2-04/S-6 4 Mpa	1
6	Zpětný filter /Regressivfilter / Reverse filter	FR 043- 166/0 10µm	1
	Vložka ve filtru / Filtereinlage / Filter lining	V3.0510-56 10µm	
7	Manometer / Manometer /Manometer	Ř 68 with Glycerin 0-6 MPa	1
8	Hydraulický zámek / Hydrauliksschloss / Hydraulic lock	VJR-04/MA	1
9	Rozváděč / Verteilungsventil / Distributor	RPE3-043Z11/02400E1K1	1
10	Tlakový spínač / Druckschalter / Pressure Switch	SUCO 0166 411 031 043	1
11	Rozváděč / Verteilungsventil / Distributor	RPE3-42R11/02400E1K1	1
12	Rozváděč / Verteilungsventil / Distributor	RPE3-043Y11/02400E1K1	1
13	Blok aretace / Arretierungblock / Locking Block	731-9002 Keine düse/No Nozzle	1
14	Blok rychloposuvu / Eilgangblock / Rapid feed blocking	729-0084	1
15	Tryska / Düse / Nozzle	Ř 1mm	1
	Designing department	ARGO-HYTOS	
	No. of type	870-1922	
	Type	SMA03-48/13.0-S11.X-H33M.0-1922/02400	

Označení hydraulických hadiček / Bezeichnung der hydraulischen Schlauche / Indication of hydraulic hose:

Hydr. hadice	Hadice	Kování	Konc. A	Konc. B	Konc. C	Konc. D	Konc. E	Konc. F	Konc. G	Ks
Hydr. Schlauche	Schlauche	Schmieden	Schlauchtüle A	B	C	D	E	F	G	Menge
Hydr. Hose	hose	forging	terminal A	B	C	D	E	F	G	piece
10BB640	42.003.001	92.051.003	-	92.053.002	-	-	-	-	-	1
10BB500	42.003.001	92.051.003	-	92.053.002	-	-	-	-	-	1
10B900	42.003.001	92.051.003	-	92.053.002	-	-	-	-	-	1
6BF2700	42.001.001	92.051.001	-	92.053.001	-	-	-	93.012.006	-	1
6AG380	42.001.001	92.051.001	92.052.001	-	-	-	-	-	93.012.005	1
6AA1300	42.001.001	92.051.001	92.052.001	-	-	-	-	-	-	1
6BF2850	42.001.001	92.051.001	-	92.053.001	-	-	-	93.012.006	-	1
6AG4000	42.001.001	92.051.001	92.052.001	-	-	-	-	-	93.012.005	1
6AA1830	42.001.001	92.051.001	92.052.001	-	-	-	-	-	-	1
6AA1500	42.001.001	92.051.001	92.052.001	-	-	-	-	-	-	1
6AB1900	42.001.001	92.051.001	92.052.001	92.053.001	-	-	-	-	-	1
6AA530	42.001.001	92.051.001	92.052.001	-	-	-	-	-	-	1
6AB970	42.001.001	92.051.001	92.052.001	92.053.001	-	-	-	-	-	1
6AA630	42.001.001	92.051.001	92.052.001	-	-	-	-	-	-	1
6AB600	42.001.001	92.051.001	92.052.001	92.053.001	-	-	-	-	-	1
6AB450	42.001.001	92.051.001	92.052.001	92.053.001	-	-	-	-	-	1
6AB600	42.001.001	92.051.001	92.052.001	92.053.001	-	-	-	-	-	1
6AB760	42.001.001	92.051.001	92.052.001	92.053.001	-	-	-	-	-	1
6AA530	42.001.001	92.051.001	92.052.001	-	-	-	-	-	-	1
6BB470	42.001.001	92.051.001	-	92.053.001	-	-	-	-	-	1
6AA1300	42.001.001	92.051.001	92.052.001	-	-	-	-	-	-	1
6AB330	42.001.001	92.051.001	92.052.001	92.053.001	-	-	-	-	-	1
6AB330	42.001.001	92.051.001	92.052.001	92.053.001	-	-	-	-	-	2
6AB600	42.001.001	92.051.001	92.052.001	92.053.001	-	-	-	-	-	1
6BA150	42.001.001	92.051.001	92.052.001	92.053.001	-	-	-	-	-	1

27. Výkresy sestav pro objednání náhradních dílů / Zeichnungen für Bestellung der Ersatzteile / Drawing assemblies for spare parts order

Při objednávání náhradních dílů vždy uvádějte: typ stroje (např. STG 120), výrobní číslo (např. 125) a rok výroby (např. 1999).

In die Bestellung der Ersatzteile führen Sie immer an:
Maschinentyp (z. B. STG 120), Serien Nr. (z. B. 125) und
Baujahr (z. B. 1999).

For spare parts order, you must always to allege: type of
machine (for example STG 120), serial number (for example 125)
and year of construction (for example 1999).

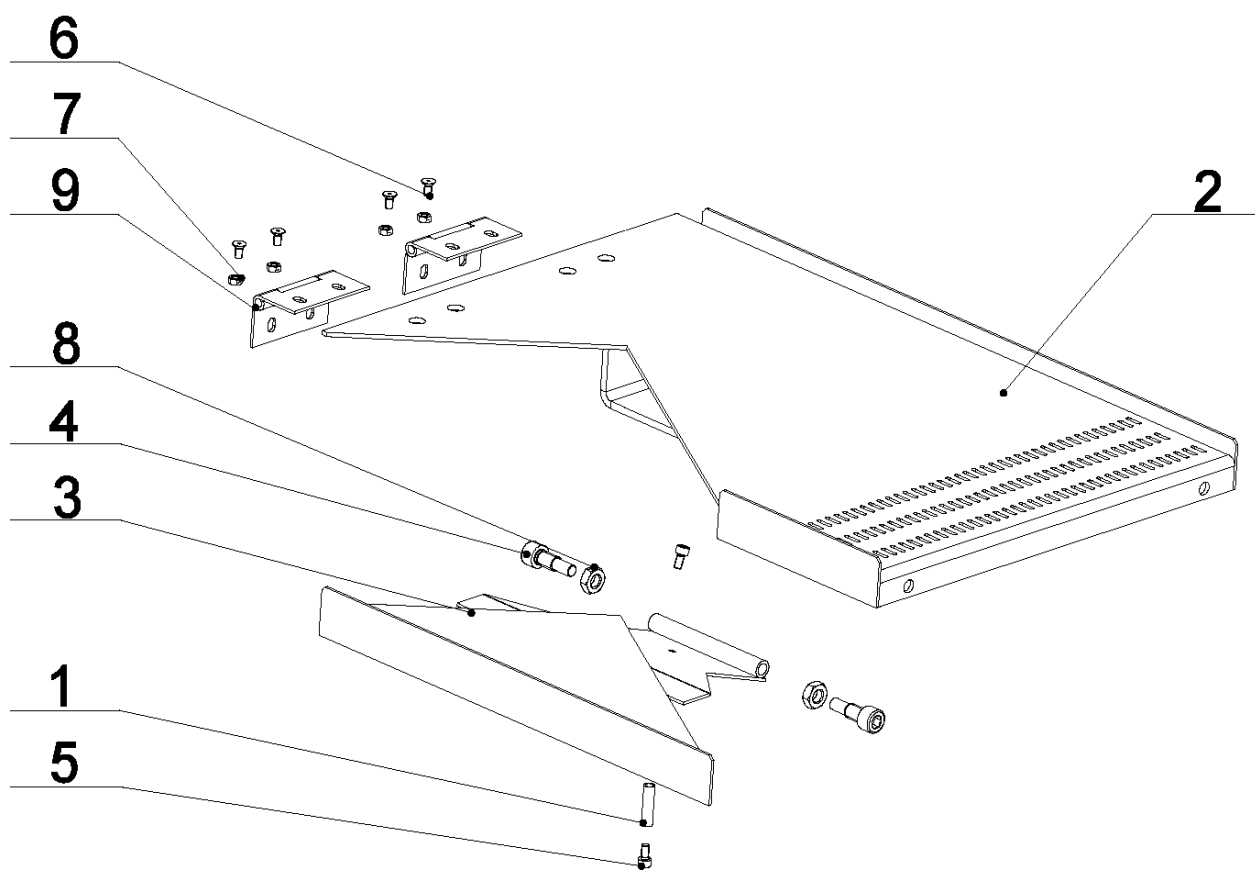

27.1. Skluz / Rutsch / Glide

Poz.	Objednací číslo	Název položky		ks
Pos.	Bestell - Nr.	Bezeichnung		Menge
Pos.	Reference No.	Item		Pcs.
1	30.1508-024	Pružina / Feder / Spring	1x7,5x28x14	1
2	30.7914-211	Skluz / Rutsch / Glide		1
3	30.7914-212	Stůl / Tisch / Desk		1
4	30.7914-305	Šroub / Schraube / Screw		2
5	90.001.25.007	Šroub / Schraube / Screw	M5x10 DIN 912	2
6	90.011.27.003	Šroub / Schraube / Screw	M5x10 DIN 7991	4
7	90.100.55.003	Matice / Mutter / Nut	M5 DIN 934	4
8	90.101.55.002	Matice / Mutter / Nut	M10 DIN 439	2
9	99.101.002	Pant / Türband / Hinge	80x70 Kz 80 Zn	2

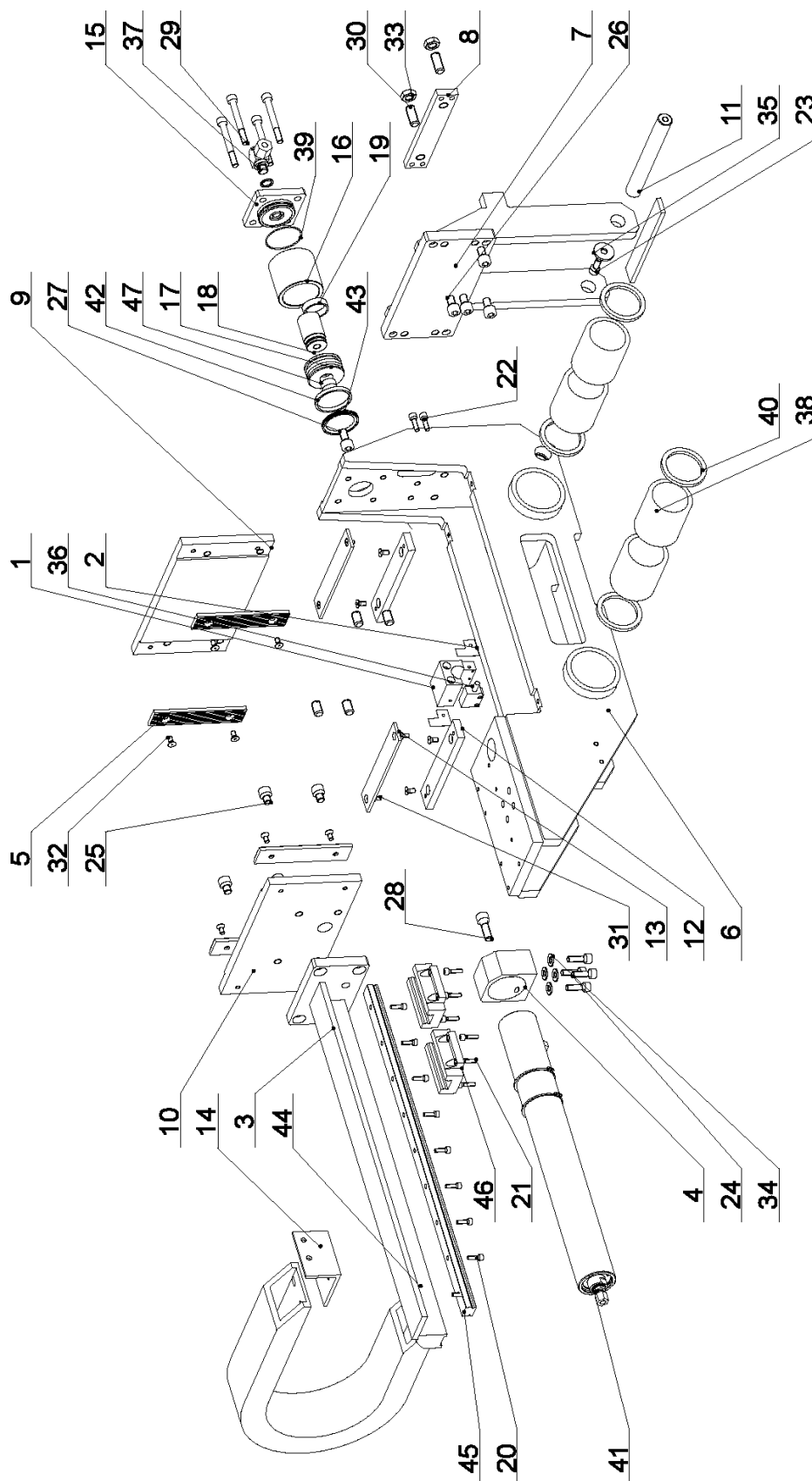

27.2. Podavač / Vorschub / Feeder

Poz.	Objednací číslo	Název položky	ks	
Pos.	Bestell - Nr.	Bezeichnung	Menge	
Pos.	Reference No.	Item	Pcs.	
1	30.2911-029	Držák snímače / Halter / Sensor holder	1	
2	30.2911-030	Stěrač / Abstreifer / Scraper	2	
3	30.7903-001	Vedení / Führung / Guiding	1	
4	30.7903-004	Kostka / Würfel / Cube	1	
5	30.7903-008	Lišta / Leiste / Listel	4	
6	30.7911-001	Těleso / Körper / Body	1	
7	30.7911-002	Pohyblivá čelist / Bewegliche Backe / Movable jaw	1	
8	30.7911-003	Příložka / Lasche / Splice plate	1	
9	30.7911-005	Deska / Platte / Plate	1	
10	30.7911-006	Deska / Platte / Plate	1	
11	30.7911-008	Čep / Bolzen / Pivot	1	
12	30.7911-009	Lišta / Leiste / Listel	2	
13	30.7911-012	Lišta / Leiste / Listel	2	
14	30.7911-014	Držák / Halter / Holder	1	
15	30.7911-051	Víko / Deckel / Cover	1	
16	30.7911-052	Trubka / Rohr / Tube	1	
17	30.7911-053	Píst / Kolben / Piston	1	
18	30.7911-054	Píst / Kolben / Piston	1	
19	30.7911-057	Pouzdro / Büchse / Bush	1	
20	90.001.25.009	Šroub / Schraube / Screw	M5x16 DIN 912	9
21	90.001.25.010	Šroub / Schraube / Screw	M5x20 DIN 912	8
22	90.001.25.018	Šroub / Schraube / Screw	M6x20 DIN 912	4
23	90.001.25.032	Šroub / Schraube / Screw	M8x20 DIN 912	2
24	90.001.25.033	Šroub / Schraube / Screw	M8x25 DIN 912	4
25	90.001.25.043	Šroub / Schraube / Screw	M10x12 DIN 912	4
26	90.001.25.045	Šroub / Schraube / Screw	M10x16 DIN 912	4
27	90.001.25.046	Šroub / Schraube / Screw	M10x20 DIN 912	1
28	90.001.25.047	Šroub / Schraube / Screw	M10x25 DIN 912	1
29	90.001.25.095	Šroub / Schraube / Screw	M8x70 DIN 912	4
30	90.002.2D.020	Šroub / Schraube / Screw	M12x30 DIN 913	2
31	90.011.27.003	Šroub / Schraube / Screw	M5x10 DIN 7991	4
32	90.011.27.005	Šroub / Schraube / Screw	M6x12 DIN 7991	12
33	90.101.55.006	Matice / Mutter / Nut	M12 DIN 439	2
34	90.150.50.005	Podložka / Scheibe / Washer	d8,4 DIN 125	4
35	90.151.50.005	Podložka / Scheibe / Washer	d9x28x3 DIN 440	2
36	91.270.007	Magnetický sensor / Sensor / Sensor	LMX2-026-08.0-1-01L	1
37	92.003.001	Šroubení natáčecí / Winkelverschraubung / Swivelling screw	RSWS 08LR	1
38	95.710.002	Kuličkové pouzdro / Kugelbuchse / Bush ball	50x70 KH	4
39	96.001.013	O kroužek / O Ring / O Ring	45x2	1
40	96.040.004	Manžeta / Manschette / Sleeve	50x62x5	4

41	96.082.002	Kroužek těsnící / Dichtungsring / Sealing ring	CU 13/17	1
42	96.084.001	Kroužek vodící / Führungsring / Guiding ring	50x5.5x2.5x145.9	1
43	96.900.001	Těsnění / Dichtung / Sealing	50x39x4	1
44	99.170.012	Řetěz energií / Energiekette / Hydr. Pipes leading	26x56/R-95	1
45	99.200.047	Vedení / Führung / Guide	HGR20R-0540	1
46	99.201.012	Vozík / Wagen / Carriage	HGW20CC	2
47	30.7911.058	Tvrdokov / HM - Segment / Hardmetal		1

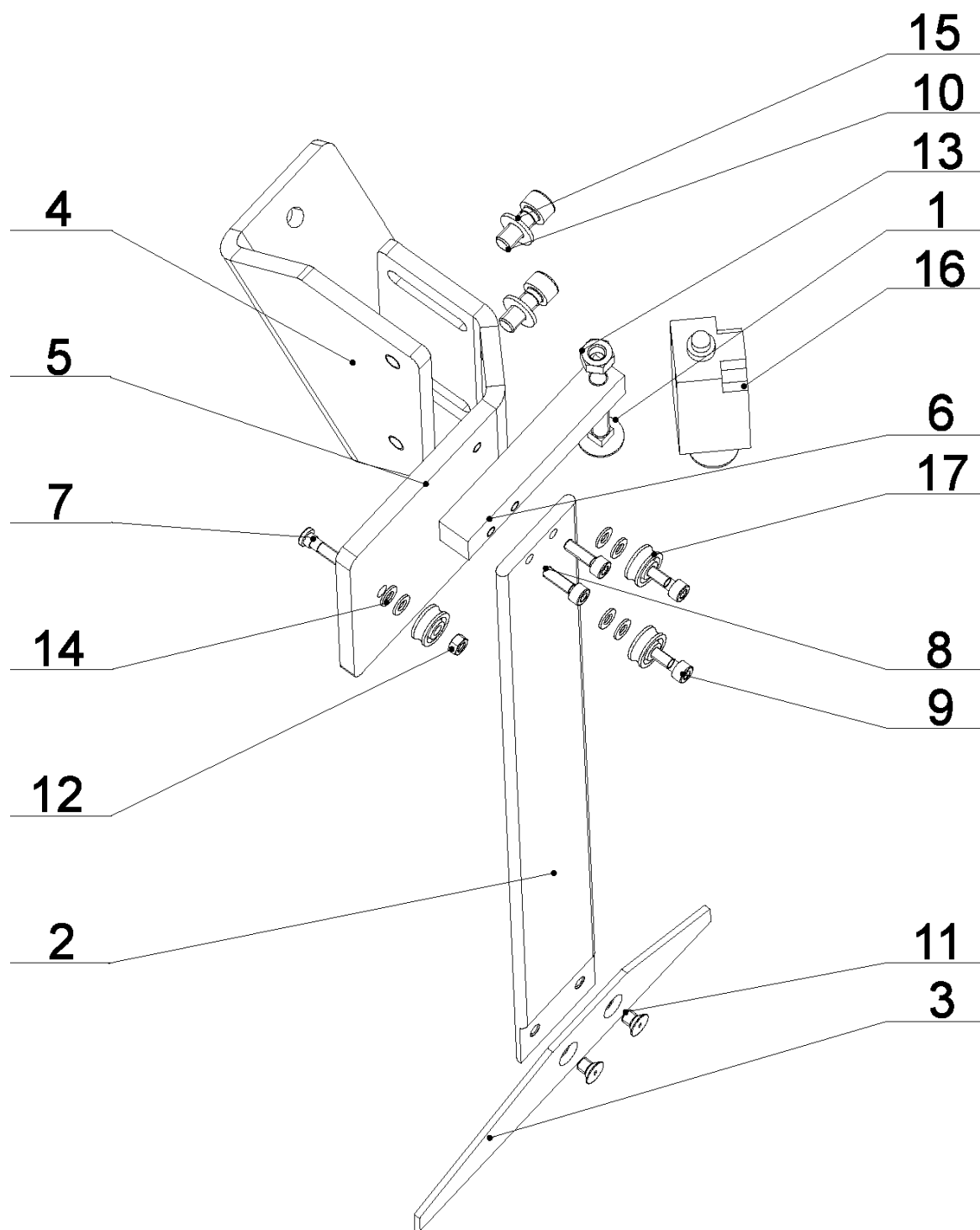

27.3. Odměřování ramene / Rahmenabmessung / Admeasurement of arm

Poz.	Objednací číslo	Název položky	ks
Pos.	Bestell - Nr.	Bezeichnung	Menge
Pos.	Reference No.	Item	Pcs.
1	30.0702-013	Šroub / Schraube / Screw	1
2	30.7904-102	Vedení / Führung / Guiding	1
3	30.7904-103	Lišta / Leiste / Listel	1
4	30.7904-106	Držák / Halter / Holder	1
5	30.7904-107	Držák / Halter / Holder	1
6	30.7904-108	Kostka / Würfel / Cube	1
7	30.7904-109	Šroub / Schraube / Screw	1
8	90.001.25.009	Šroub / Schraube / Screw M5x16 DIN 912	2
9	90.001.25.010	Šroub / Schraube / Screw M5x20 DIN 912	2
10	90.001.25.032	Šroub / Schraube / Screw M8x20 DIN 912	2
11	90.011.27.XXX	Šroub / Schraube / Screw M6x8 DIN 7991	2
12	90.100.55.003	Matice / Mutter / Nut M5 DIN 934	1
13	90.100.55.005	Matice / Mutter / Nut M8 DIN 934	1
14	90.150.50.003	Podložka / Scheibe / Washer d5,3 DIN 125	6
15	90.150.50.005	Podložka / Scheibe / Washer d8,4 DIN 125	2
16	91.173.007	Koncový spínač / Endschalter / Limit switch FR 601-M02	1
17	95.008.001	Ložisko / Lager / Bearing YRLR20/5	3

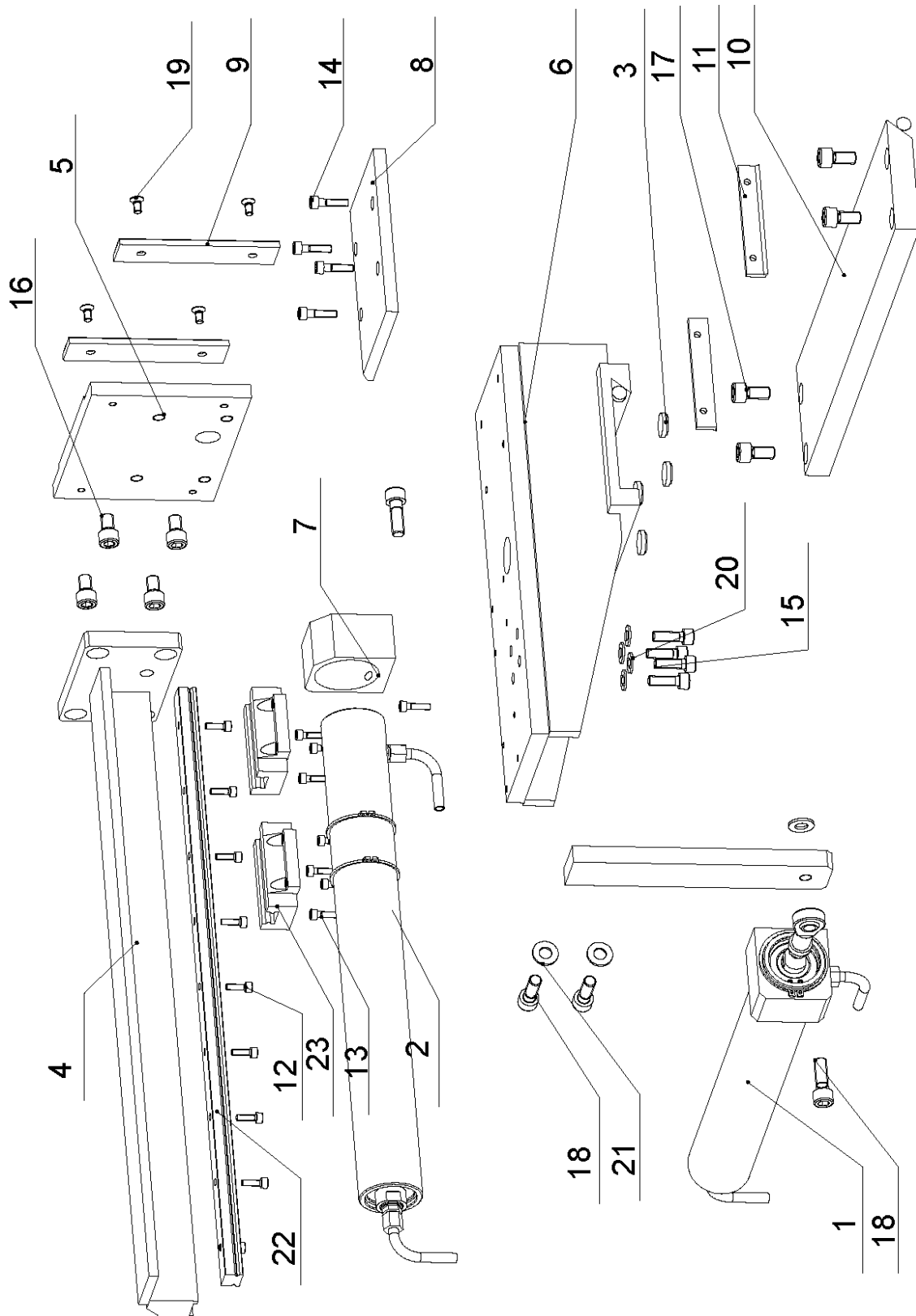

27.4. Svěrák hlavní / Hauptschraubstock / Main vice

Poz.	Objednací číslo	Název položky	ks
Pos.	Bestell - Nr.	Bezeichnung	Menge
Pos.	Reference No.	Item	Pcs.
1	201.7907-100	Pomocný válec / Hilfszylinder / Auxiliary cylinder	1
2	201.7907-200	Válec svěráku / Zylinder / Vice cylinder	1
3	30.0509-608	Podložka / Scheibe / Washer	4
4	30.7903-001	Vedení / Führung / Guide	1
5	30.7903-002	Čelist / Backe / Jaw	1
6	30.7903-003	Těleso svěráku / Körper / Vice body	1
7	30.7903-004	Kostka / Würfel / Cube	1
8	30.7903-005	Deska / Platte / Plate	1
9	30.7903-008	Lišta / Leiste / Listel	2
10	30.7903-013	Vodící deska / Führungsplatte / Guiding plate	1
11	30.7903-014	Stěrač / Abstreifer / Scraper	2
12	90.001.25.009	Šroub / Schraube / Screw	M5x16 DIN 912 9
13	90.001.25.010	Šroub / Schraube / Screw	M5x20 DIN 912 8
14	90.001.25.019	Šroub / Schraube / Screw	M6x25 DIN 912 4
15	90.001.25.033	Šroub / Schraube / Screw	M8x25 DIN 912 4
16	90.001.25.045	Šroub / Schraube / Screw	M10x16 DIN 912 4
17	90.001.25.046	Šroub / Schraube / Screw	M10x20 DIN 912 4
18	90.001.25.047	Šroub / Schraube / Screw	M10x25 DIN 912 4
19	90.011.27.005	Šroub / Schraube / Screw	M6x12 DIN 7991 4
20	90.150.50.005	Podložka / Scheibe / Washer	d8,4 DIN 125 4
21	90.150.50.006	Podložka / Scheibe / Washer	d10,5 DIN 125 3
22	99.200.047	Vedení / Führung / Guide	HGR20R-0540 1
23	99.201.012	Vozík / Wagen / Carriage	HCW20CC 2

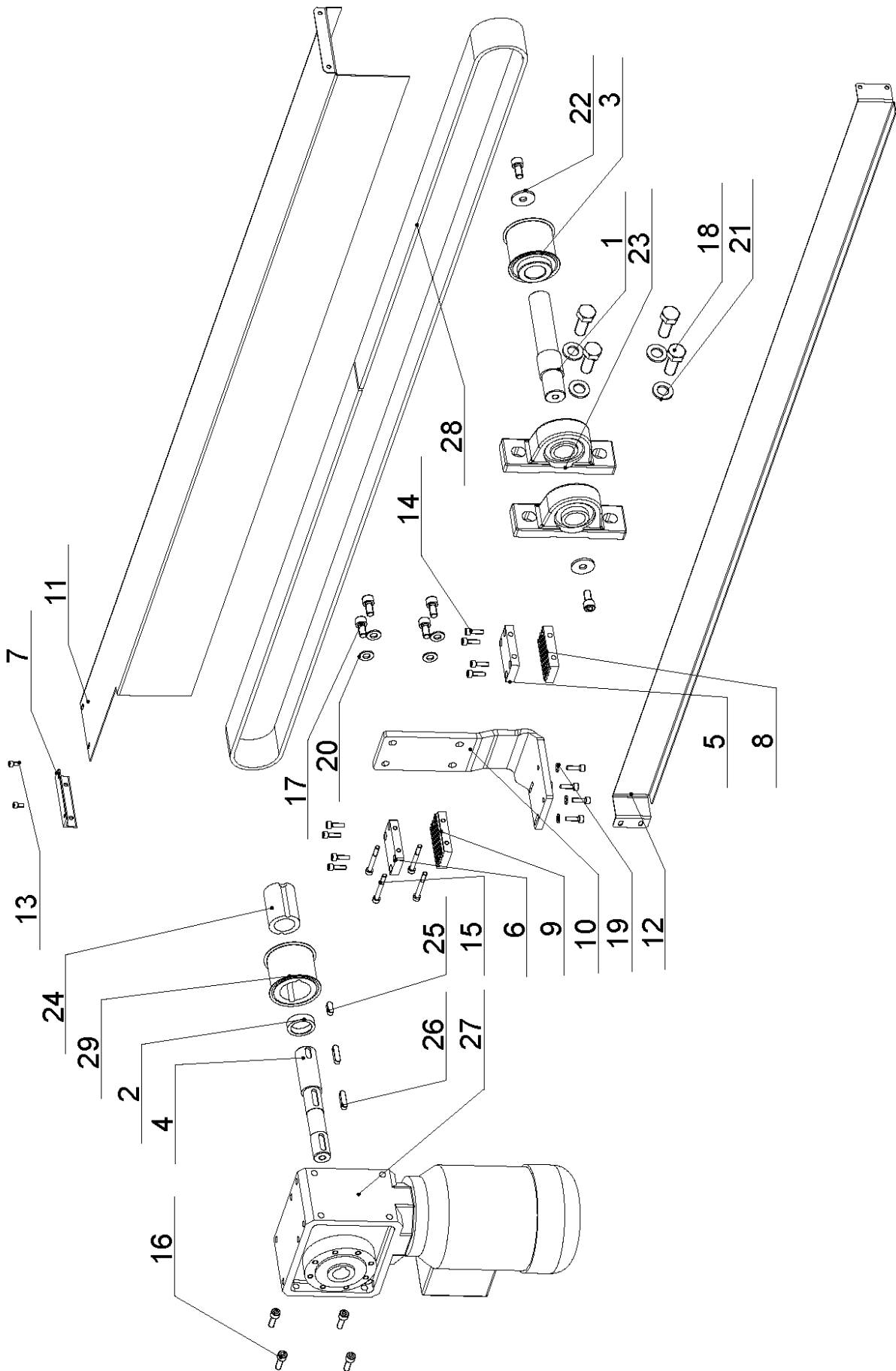

27.5. Pohon / Antrieb / Drive

Poz.	Objednací číslo	Název položky	ks
Pos.	Bestell - Nr.	Bezeichnung	Menge
Pos.	Reference No.	Item	Pcs.
1	30.7911-102	Hřídel / Welle / Shaft	1
2	30.7911-103	Kroužek distanční / Distanzring / Distance ring	1
3	30.7911-104	Řemenice / Riemenscheibe / Band - wheel	1
4	30.7911-106	Hřídel / Welle / Shaft	1
5	30.7911-108	Deska / Platte / Plate	1
6	30.7911-109	Deska / Platte / Plate	1
7	30.7911-110	Lišta / Leiste / Listel	1
8	30.7911-111	Deska / Platte / Plate	1
9	30.7911-112	Deska / Platte / Plate	1
10	30.7911-114	Držák / Halter / Holder	1
11	30.7911-115	Kryt řemene / Deckel / Belt cover	1
12	30.7911-119	Kryt / Deckel / Cover	1
13	90.001.25.007	Šroub / Schraube / Screw M5x10 DIN 912	2
14	90.001.25.018	Šroub / Schraube / Screw M6x20 DIN 912	12
15	90.001.25.024	Šroub / Schraube / Screw M6x55 DIN 912	4
16	90.001.25.033	Šroub / Schraube / Screw M8x25 DIN 912	4
17	90.001.25.046	Šroub / Schraube / Screw M10x20 DIN 912	6
18	90.005.55.049	Šroub / Schraube / Screw M16x40 DIN 933	4
19	90.150.50.004	Podložka / Scheibe / Washer d6,4 DIN 125	4
20	90.150.50.006	Podložka / Scheibe / Washer d10,5 DIN 125	4
21	90.150.50.009	Podložka / Scheibe / Washer d17 DIN 125	4
22	90.151.50.001	Podložka / Scheibe / Washer d10 DIN 440	2
23	95.160.002	Ložisko / Lager / Bearing 206	2
24	95.710.004	Pouzdro / Lager / Bearing Taper lock 1210	1
25	95.810.006	Pero / Feder / Feather 8x7x20	1
26	95.810.015	Pero / Feder / Feather 8x7x30	2
27	99.001.030	Převodovka šneková / Schneckengetriebe / Worm gearbox W63/U/10-0,55kW	1
28	99.024.006	Řemen ozubený / Zahnriemen / Toothed belt HTD 8M 50	1
29	99.280.014	Řemenice / Riemenscheibe / Band - wheel 28-8M-50F HTD T	1

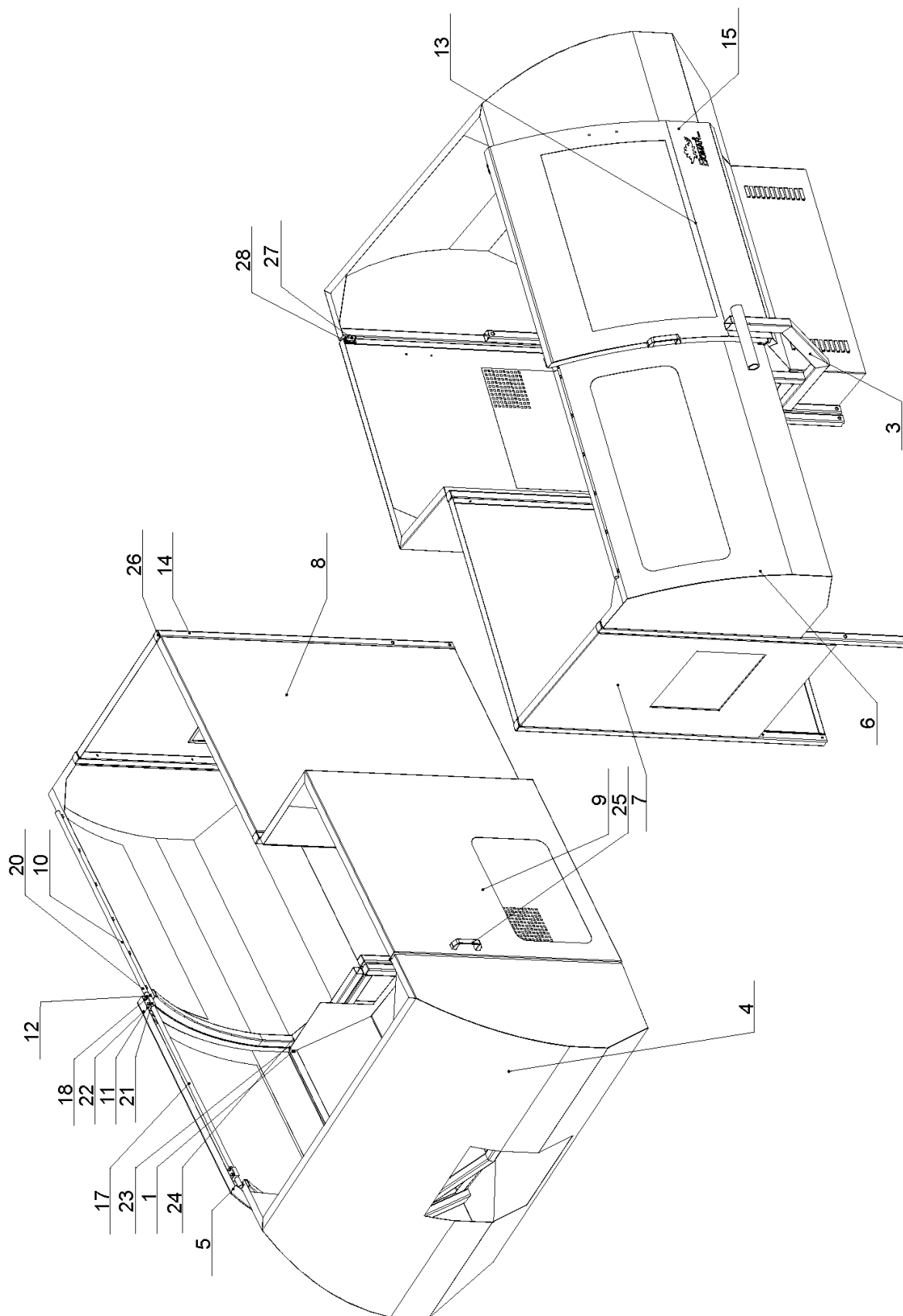

27.6. Kryt / Deckel / Cover

Poz.	Objednáací číslo	Název položky	ks
Pos.	Bestell - Nr.	Bezeichnung	Menge
Pos.	Reference No.	Item	Pcs.
1	201.7914-120	Kladka / Rolle / Pulley	1
2	30.7901-016-1	Plast / Plast / Plastic	1
3	30.7901-025	Konzola / Konsole / Console	1
4	30.7914-101	Kryt přední / Deckel / Front cover	1
5	30.7914-102	Kryt / Deckel / Cover	1
6	30.7914-103	Kryt / Deckel / Cover	1
7	30.7914-104	Kryt / Deckel / Cover	1
8	30.7914-105	Kryt / Deckel / Cover	1
9	30.7914-106	Dveře / Tür / Door	1
10	30.7914-107	Tyč vodící / Führungsstange / Guiding bar	1
11	30.7914-108	Držák / Halter / Holder	2
12	30.7914-109	Kostka / Würfel / Cube	2
13	30.7914-111	Konzola / Konsole / Console	1
14	30.7914-112	Stojina / Säule / Pillar	3
15	30.7914-113	Kostka / Würfel / Cube	1
16	30.7914-114	Kryt / Deckel / Cover	1
17	30.7914-115	Tyč vodící / Führungsstange / Guiding bar	1
18	30.7914-117	Podložka / Scheibe / Washer	8
19	30.7914-119	Stojina / Säule / Pillar	1
20	90.001.25.018	Šroub / Schraube / Screw M6x20 DIN 912	6
21	90.005.55.008	Šroub / Schraube / Screw M6x20 DIN 933	8
22	90.005.55.013	Šroub / Schraube / Screw M8x12 DIN 933	1
23	90.150.50.004	Podložka / Scheibe / Washer d6,4 DIN125	15
24	90.150.50.005	Podložka / Scheibe / Washer d8,4 DIN	1
25	94.012.001	Rukojeť / Griff / Handle 503-043-151x42	2
26	94.101.005	Zátka / Stopfen / Stopper 40x40x3	5
27	99.061.001	Magnet / Magnet / Magnet 02-035I	2
28	99.062.001	Přichytka magnetu / Magnetklamme / Magnet holder	2
29	99.100.007	Pant / Türband / Hinge 800055	2

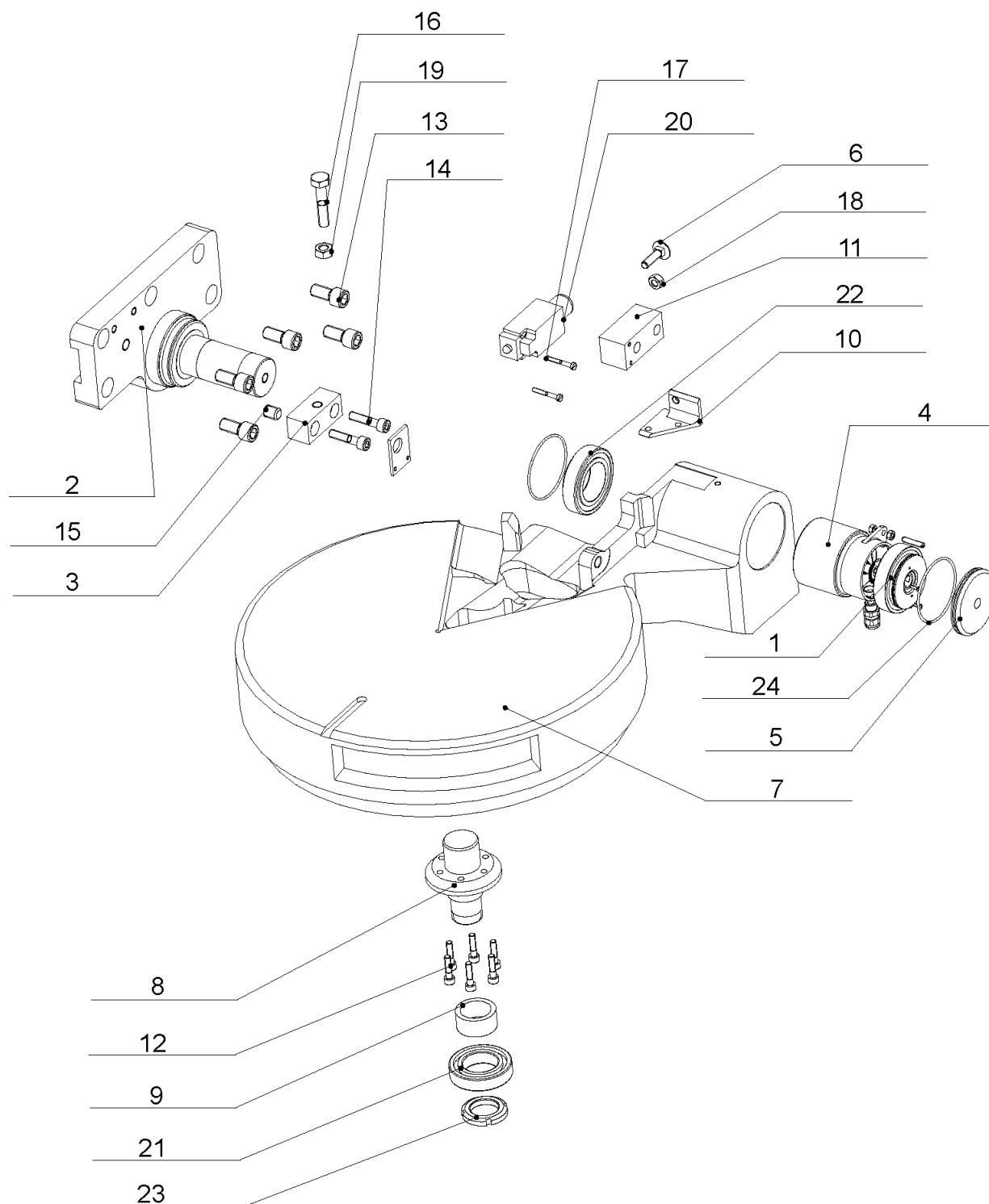

27.7. Konzola otočná / Drehkonsole / Turning console

Poz.	Objednací číslo	Název položky	ks	
Pos.	Bestell - Nr.	Bezeichnung	Menge	
Pos.	Reference No.	Item	Pcs.	
1.	201.0614-200	Odměrování úhlu / Gehrungsmessung / Admeasurement of angles	1	
2.	30.0502-604	Držák ramene / Halter / Arm holder	1	
3.	30.0502-610	Držák koncového spínače / Halter / Limit switch holder	1	
4.	30.0702-008	Pouzdro / Büchse / Bush	1	
5.	30.0702-012	Víko / Deckel / Cover	1	
6.	30.0702-013	Šroub / Schraube / Screw	1	
7.	30.7902-001	Konzola otočná / Drehkonsole / Turning console	1	
8.	30.7902-002	Čep / Bolzen / Pivot	1	
9.	30.7902-005	Kroužek distanční / Distanzring / Distance ring	1	
10.	30.7902-008	Držák / Halter / Holder	1	
11.	30.7902-009	Kostka / Würfel / Cube	1	
12.	90.001.25.019	Šroub / Schraube / Screw	M6x25 DIN912	6
13.	90.001.25.057	Šroub / Schraube / Screw	M12x25 DIN 912	5
14.	90.001.55.035	Šroub / Schraube / Screw	M8x35 DIN 912	2
15.	90.002.2D.017	Šroub / Schraube / Screw	M12x16 DIN 913	1
16.	90.005.55.007	Šroub / Schraube / Screw	M10x50 DIN 933	1
17.	90.012.50.007	Šroub / Schraube / Screw	M4x30 DIN 84	2
18.	90.100.55.005	Matice / Mutter / Nut	M8 DIN 934	1
19.	90.100.55.006	Matice / Mutter / Nut	M10 DIN 934	1
20.	91.173.007	Koncový spínač / Endschalter / Limit switch	1xNO/1xNC	1
21.	95.001.010	Ložisko / Lager / Bearing	6007 2RS	1
22.	95.300.002	Ložisko / Lager / Bearing	32008AX	2
23.	95.850.011	Matice / Mutter / Nut	KM6	2
24.	96.001.018	Těsnění / Dichtung / Sealing	63x2 NBR 70Sh	2

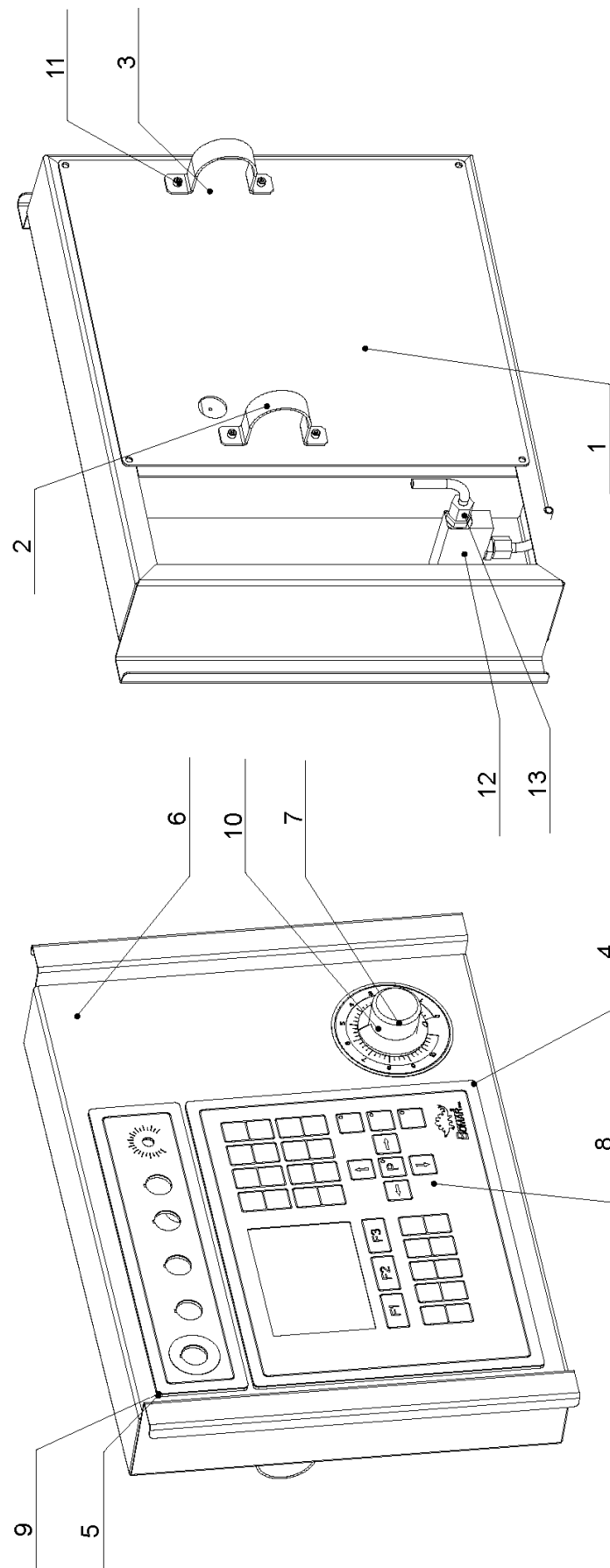

27.8. Panel / Panel / Panel

Poz.	Objednací číslo	Název položky	ks	
Pos.	Bestell - Nr.	Bezeichnung	Menge	
Pos.	Reference No.	Item	Pcs.	
1.	30.7913-004	Kryt / Deckel / Cover	1	
2.	30.7913-005	Objímka / Klammerstück / Socket	2	
3.	30.7913-006	Příložka / Lasche / Splice plate	2	
4.	30.7913-007	Deska panelu / Deckel / Cover	1	
5.	30.7913-008	Deska panelu / Deckel / Cover	1	
6.	30.7913-009	Pult / Pult / Board	1	
7.	30.8814-207	Kolečko / Rolle / Wheel	1	
8.	31.7913-001	Klávesnice / Tastatur / Keyboard	1	
9.	31.7913-002	Panel tlačítek / Panel / Panel	1	
10.	31.7913-003	Štítek / Schild / Label	1	
11.	90.001.25.016	Šroub / Schraube / Screw	M6x12 DIN 912	4
12.	92.152.001	Ventil škrtící / Drosselventil / Throttle-valve	VS01-04/R 2,5-0	1
13.	93.006.003	Šroubení / Schraube / Screw	G 1/4" - 8/6	2

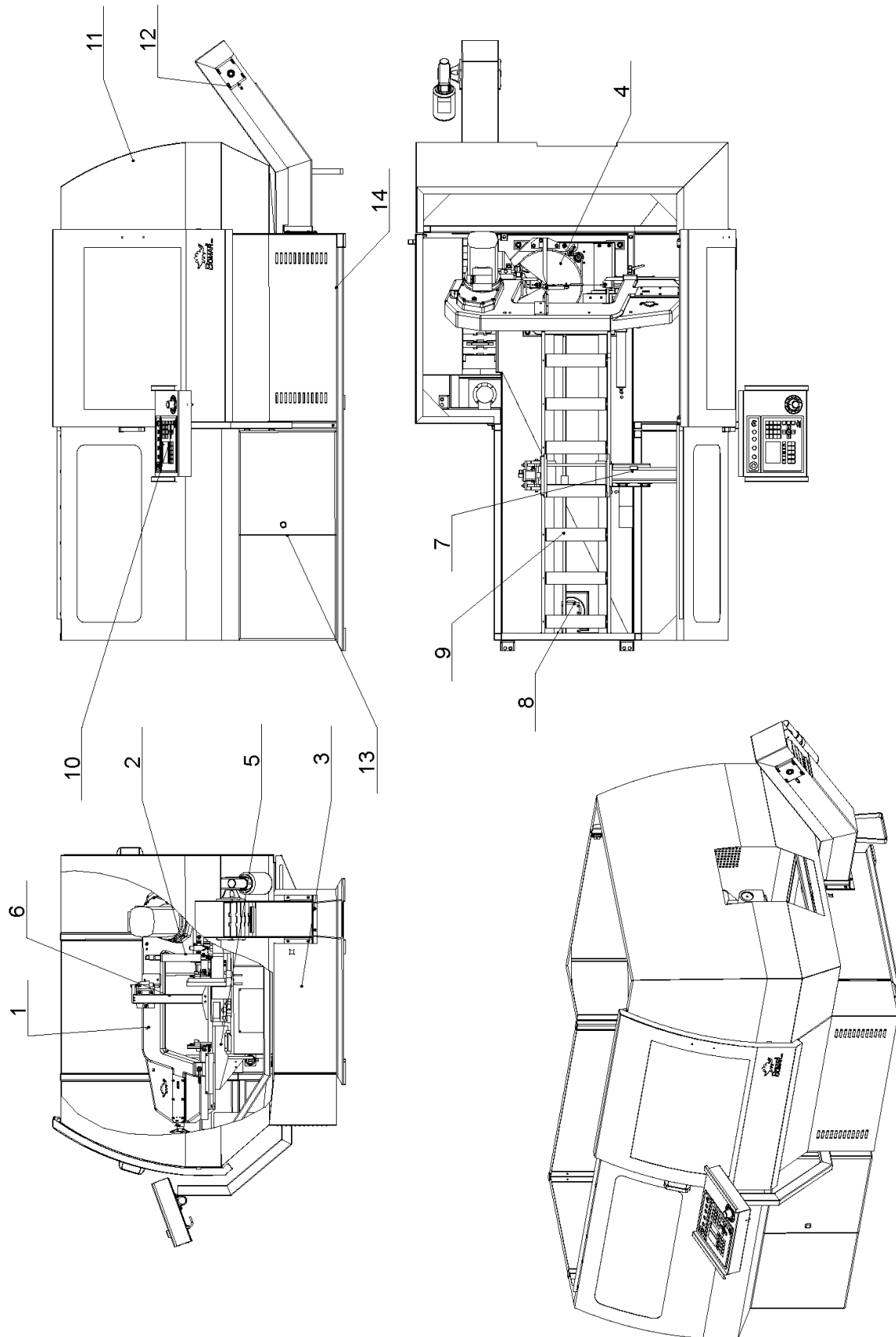

27.9. Pásová pila / Bandsäge / Band saw

Poz.	Objednací číslo	Název položky	ks
Pos.	Bestell - Nr.	Bezeichnung	Menge
Pos.	Reference No.	Item	Pcs.
1	201.0504-600	Rameno / Sägerahmen / Saw arm	1
2	201.0507-910	Hydraulický válec / Hydraulikzylinder / Hydraulic cylinde	1
3	201.7901-000	Podstavec pily / Sägeuntergestell / Saw pedestal	1
4	201.7902-000	Konzola / Konsole / Console	1
5	201.7903-000	Svěrák hlavní / Hauptschraubstock / Main vice	1
6	201.7904-100	Odměřování ramene / Rahmenabmesung / Admeasurement of arm	1
7	201.7911-000	Podavač / Vorschub / Feeder	1
8	201.7911-100	Pohon podavače / Vorschupantrieb / Feeder drive	1
9	201.7911-200	Válečková trať / Rollenbahn / Roll conveyor	1
10	201.7913-000	Panel ovládání / Panel / Panel	1
11	201.7914-000	Kryt / Deckel / Cover	1
12	201.7917-000	Vynašeč třísek / Späneförderer / Chip remover	1
13	31.7930-001	Rozvaděč / Schaltschrank / Switchboard	1
14	92.001.038	Agregát hydraulický / Hydraulischeaggregat / Hydraulic aggregate 250DGA	1

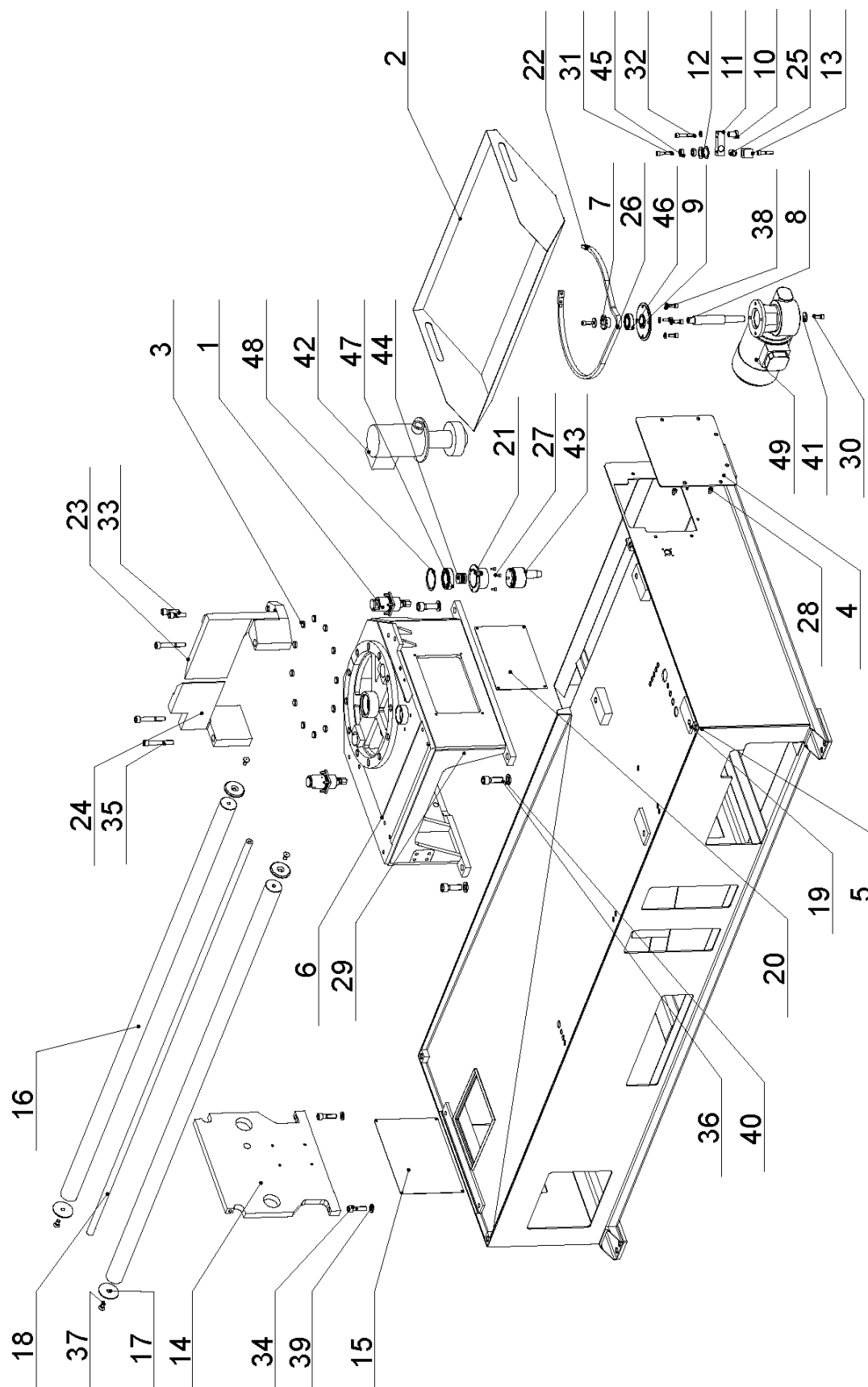
27.10. Podstavec / Untergestell / Pedestal

Poz.	Objednací číslo	Název položky	ks
Pos.	Bestell - Nr.	Bezeichnung	Menge
Pos.	Reference No.	Item	Pcs.
1.	201.7907-300	Válec fixační / Fixierzylinder / Fixation cylinder	2
2.	30.0501-002	Skluz / Rutsch / Glide	1
3.	30.0509-608	Podložka / Scheibe / Washer	12
4.	30.7201-103	Kryt / Deckel / Cover	1
5.	30.7901-001	Podstavec pily // Saw pedestal	1
6.	30.7901-002	Podstavec svěráku // Vice pedestal	1
7.	30.7901-003	Kolo řetězové // Chain wheel	1
8.	30.7901-005	Hřídel / Welle / Shaft	1
9.	30.7901-006	Příruba / Flansche / Flange	1
10.	30.7901-007	Čep / Bolzen / Pivot	1
11.	30.7901-008	Páka / Hebel / Lever	1
12.	30.7901-009	Kladka / Rolle / pulley	1
13.	30.7901-013	Kostka / Würfel / Cube	1
14.	30.7901-014	Čelo / Stirn / Forehead	1
15.	30.7901-015	Víko / Deckel / Cover	1
16.	30.7901-017	Vodící tyč / Führungsstange / Guiding bar	2
17.	30.7901-018	Podložka / Scheibe / Washer	4
18.	30.7901-022	Tyč odměřování / Abmessungsstange / Measuring bar	1
19.	30.7901-023	Kryt / Deckel / Cover	1
20.	30.7901-029	Víko / Deckel / Cover	1
21.	30.7901-031	Příruba / Flansche / Flange	1
22.	30.7902-004	Držák řetězu / Kettehalter / Chain holder	2
23.	30.7902-006	Čelist pevná / Feste Backe / Fixed jaw	1
24.	30.7902-007	Čelist pevná / Feste Backe / Fixed jaw	1
25.	31.1507-705	Pružina / Feder / Spring	1
26.	49.200.001	Řetěz pohonový / Antriebkette / Driving chain	1
27.	90.001.25.007	Šroub / Schraube / Screw M5x10 DIN 912	3
28.	90.001.25.028	Šroub / Schraube / Screw M8x10 DIN 912	6
29.	90.001.25.031	Šroub / Schraube / Screw M8x16 DIN 912	1
30.	90.001.25.032	Šroub / Schraube / Screw M8x20 DIN 912	6
31.	90.001.25.036	Šroub / Schraube / Screw M8x40 DIN 912	2
32.	90.001.25.038	Šroub / Schraube / Screw M8x50 DIN 912	1
33.	90.001.25.060	Šroub / Schraube / Screw M12x40 DIN 912	2
34.	90.001.25.061	Šroub / Schraube / Screw M12x45 DIN 912	2
35.	90.001.25.065	Šroub / Schraube / Screw M12x80 DIN 912	3
36.	90.001.25.074	Šroub / Schraube / Screw M16x45 DIN 912	4
37.	90.011.27.008	Šroub / Schraube / Screw M10x20 DIN 7991	4
38.	90.150.50.005	Podložka / Scheibe / Washer d8,4 DIN 125	6
39.	90.150.50.007	Podložka / Scheibe / Washer d13 DIN 125	2
40.	90.150.50.009	Podložka / Scheibe / Washer d17 DIN 125	4
41.	90.151.50.005	Podložka / Scheibe / Washer d9x28x3 DIN 440	3

42.	91.020.009	Čerpadlo chlazení / Kühlmittelpumpe / Coolant pump	2COP1-14 (POM)	1
43.	91.103.101	Čidlo / Sensor / Sensor	IRC G0356.B25572	1
44.	91.103.102	Spojka / Konjunktion / Conjunction	kIRC,Z121.C02plast	1
45.	95.001.001	Ložisko / Lager / Bearing	608	2
46.	95.001.008	Ložisko / Lager / Bearing	6005	1
47.	95.001.010	Ložisko / Lager / Bearing	6007	1
48.	95.801.010	Kroužek pojistný vnitřní / Sicherungsring / Retaining ring	d62	1
49.	99.001.029	Převodovka šneková / Schneckengetriebe / Worm gearbox	MVF 44/F/20-0,37	1

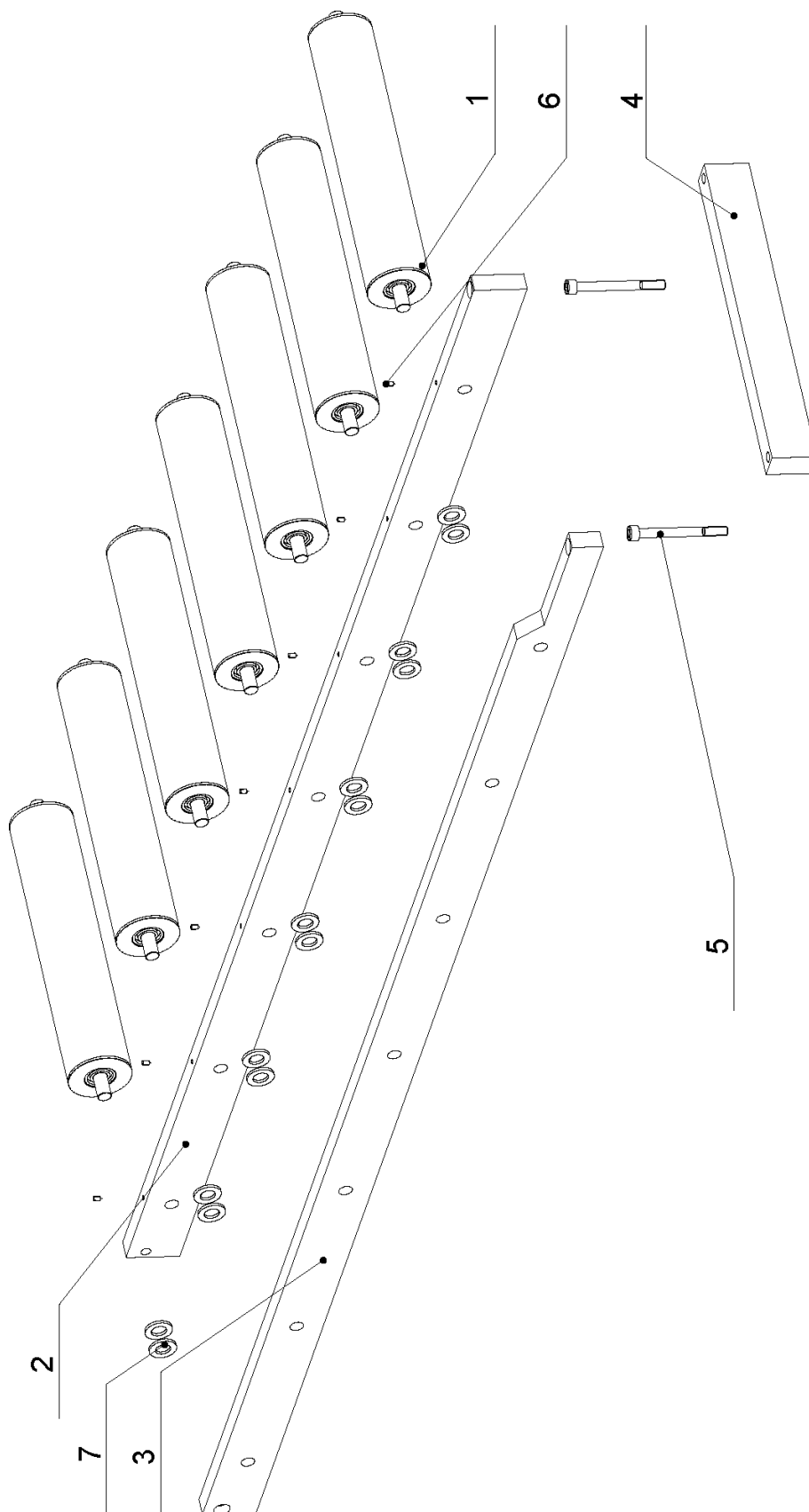

27.11. Válečková trať / Rollenbahn / Roll conveyor

Poz.	Objednací číslo	Název položky	ks
Pos.	Bestell - Nr.	Bezeichnung	Menge
Pos.	Reference No.	Item	Pcs.
1	201.7911-210	Váleček / Rolle / Roller	7
2	30.7911-201	Tyč / Stange / Bar	1
3	30.7911-202	Tyč / Stange / Bar	1
4	30.7911-203	Hranol / Prisma / Prism	1
5	90.001.25.069	Šroub / Schraube / Screw M10x100 DIN 912	2
6	90.003.2D.002	Šroub / Schraube / Screw M5x10 DIN 914	7
7	90.150.50.009	Podložka / Scheibe / Washer d17 DIN 125	21

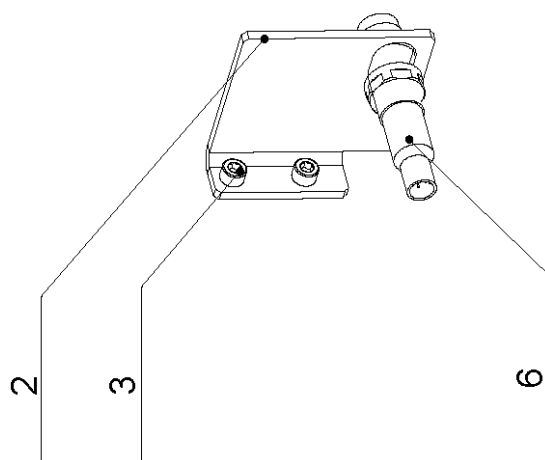
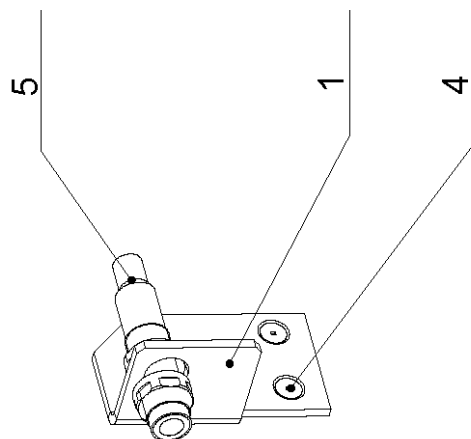

27.12. Závora optická / Lichtsperre / Laser beam

Poz.	Objednací číslo	Název položky	ks
Pos.	Bestell - Nr.	Bezeichnung	Menge
Pos.	Reference No.	Item	Pcs.
1	30.7911-311	Držák / Halter / Holder	1
2	30.7911-312	Držák / Halter / Holder	1
3	90.001.25.015	Šroub / Schraube / Screw M6x10 DIN 912	2
4	90.011.27.004	Šroub / Schraube / Screw M6x10 DIN 7991	2
5	91.400.001	Snímač / Sensor / Sensor BLE	1
6	91.400.002	Snímač / Sensor / Sensor BLS	1

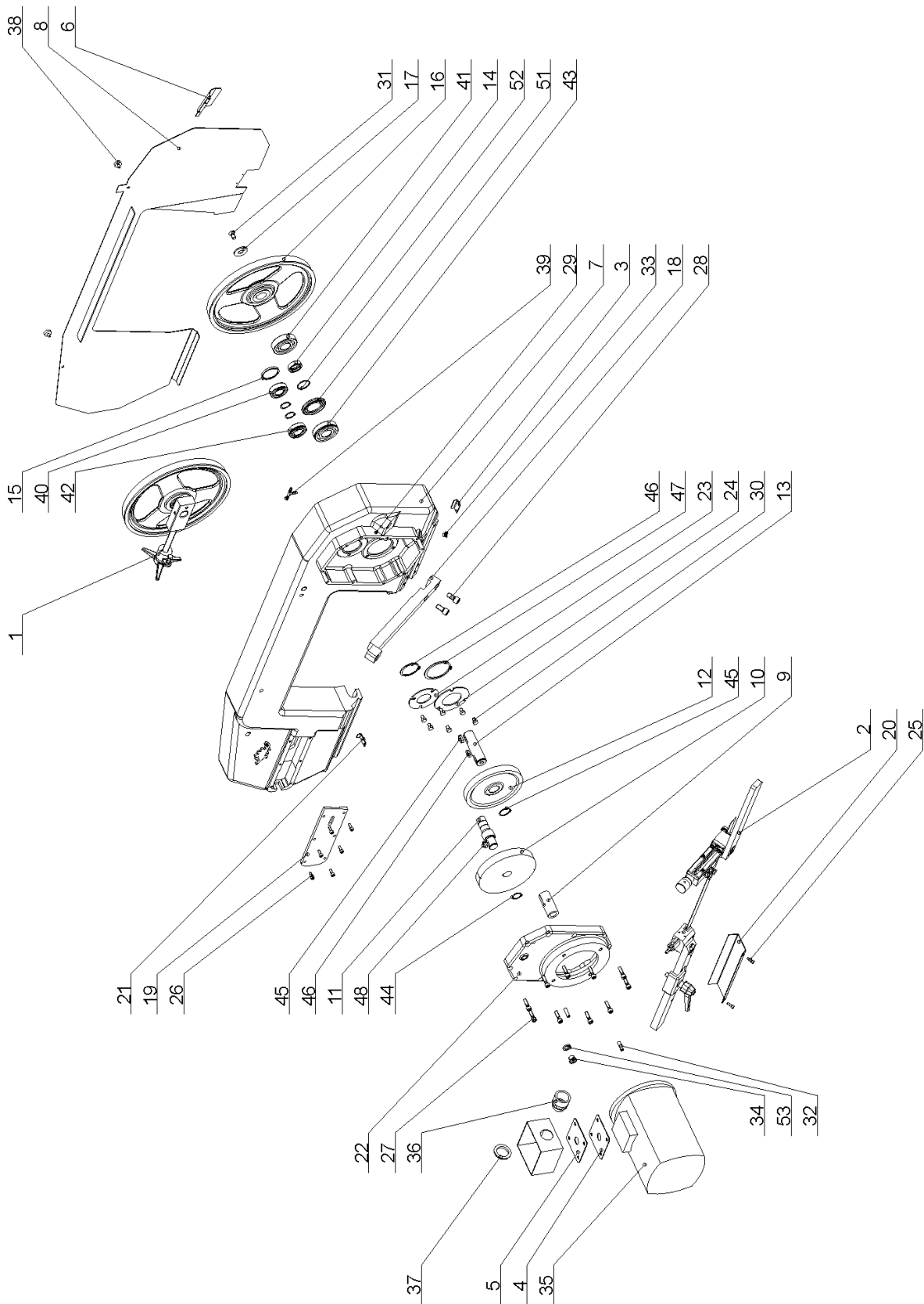
27.13. Rameno a pohon / Sägerahmen und Antrieb / Saw band and drive - 251.038

Poz.	Objednací číslo	Název položky	ks
Pos.	Bestell - Nr.	Bezeichnung	Menge
Pos.	Reference No.	Item	Pcs.
1	Viz výkres / siehe Zeichnung / see drawing	Napínání / Sägebandspannung / Stretching	1
2	Viz výkres / siehe Zeichnung / see drawing	Vedení pásu / Sägebandführung / Saw band guiding	1
3	30.0104-029	Úchytka široká / Halter / Angle cleat wide	1
4	30.0504-004	Víko / Deckel / Cover	1
5	30.0504-005	Víko těsnění / Deckel / Sealing cover	1
6	30.0504-602-2	Kryt kartáčku / Bürstenabdeckung / Brush cover	1
7	30.0504-701	Rameno / Sägerahmen / Saw arm	1
8	30.0504-750	Kryt ramene / Rahmendeckel / Arm cover	1
9	30.0505-002	Pastorek / Ritzel / Pinion	1
10	30.0505-003	Ozubené kolo / Zahnrad / Gear wheel	1
11	30.0505-004	Předloha / Vorgelege / Countershaft	1
12	30.0505-005	Ozubené kolo / Zahnrad / Gear wheel	1
13	30.0505-007	Hřídel / Welle / Shaft	1
14	30.0505-009	Kroužek / Ring / Ring	1
15	30.0505-013	Zátka převodovky / Verschlusschraube / Gearbox plug	1
16	30.0505-701	Hnací kolo / Antriebsrad / Driving wheel	1
17	30.0508-002	Podložka / Scheibe / Washer	1
18	30.0514-901	Držák / Halterung / Holder	1
19	30.0704-007	Víko napínání / Sägebandspannungsdeckel / Stretching cover	1
20	30.0704-021	Kryt pásu / Banddeckel / Band cover	1
21	30.0704-032	Úchytka úzká / Halter / Angle cleat narrow	1
22	30.0705-001	Víko převodovky / Deckel / Gearbox cover	1
23	81.0105-007	Kroužek / Ring / Ring	1
24	81.0505-010	Příložka / Lasche / Splice plate	1
25	90.001.25.009	Šroub / Schraube / Screw M5x16 DIN 912	2
26	90.001.25.017	Šroub / Schraube / Screw M6x16 DIN 912	6
27	90.001.25.034	Šroub / Schraube / Screw M8x30 DIN 912	10
28	90.001.25.057	Šroub / Schraube / Screw M12x25 DIN 912	2
29	90.004.2D.001	Šroub / Schraube / Screw M6x8 DIN 915	1
30	90.005.55.013	Šroub / Schraube / Screw M8x12 DIN 933	6
31	90.011.27.008	Šroub / Schraube / Screw M10x20 DIN 7991	1
32	90.302.0Z.002	Kuželový kolík+závit / Kegelstift / Taper pin+thread M8x30 DIN 7978	2
33	90.400.5Z.001	Napouštěcí zátka / Verschlusschraube / Fill stopper 10x1 DIN 908	1
34	90.400.5Z.002	Napouštěcí zátka / Verschlusschraube / Fill stopper 16x1,5 DIN 908	1
35	91.001.007	Elektromotor / Elektromotor / Electromotor (TM) 90 2/4 B5	1
36	91.071.004	Vývodka hadice / Verschraubung Gerade / Hose bushing	1
37	91.072.007	Matice / Mutter / Nut	1
38	94.007.002	Plastový šroub / Rändelschraube / Plastic screw M6x10	2
39	94.200.001	Rozdvojka / Verteiler / Adaptor T	1
40	95.001.018	Ložisko / Lager / Bearing 6205 2RS	1
41	95.001.025	Ložisko / Lager / Bearing 6306 2RS	1
42	95.003.002	Ložisko / Lager / Bearing 6205 2ZNR	1
43	95.003.003	Ložisko / Lager / Bearing 6306 2ZNR	1
44	95.800.012	Pojistný kroužek / Sicherungsring / Retaining ring Ø25 DIN 471	3
45	95.800.013	Pojistný kroužek / Sicherungsring / Retaining ring Ø30 DIN 471	1

46	95.800.019	Pojistný kroužek / Sicherungsring / Retaining ring	Ø52 DIN 471	1
47	95.800.XXX	Pojistný kroužek / Sicherungsring / Retaining ring	Ø72 DIN 471	1
48	95.810.006	Pero / Feder / False key	8x7x20	1
49	95.810.007	Pero / Feder / False key	8x7x25	1
50	95.810.023	Pero / Feder / False key	8x7x22 RZ	1
51	95.830.005	Hřídelové těsnění / Wellendichtung / Shaft seal	40x72x7	1
52	96.002.034	O kroužek / O Ring / O Ring	30x2	1
53	96.081.001	Těsnící kroužek / Dichtungsring / Sealing ring	23x15x3	1

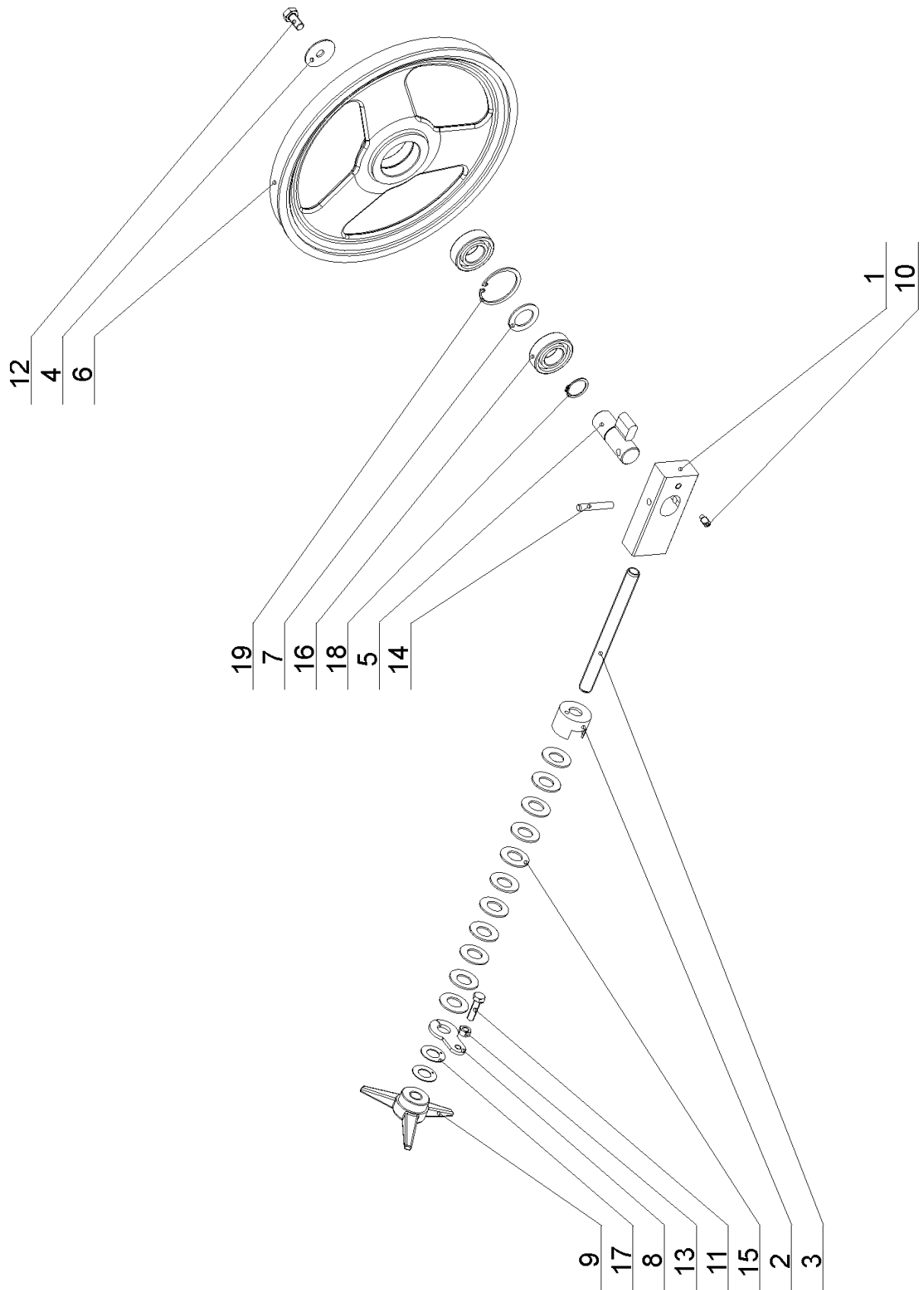

27.14. Napínání pilového pásu / Sägebandspannung / Saw band stretching

Poz.	Objednací číslo	Název položky	ks
Pos.	Bestell - Nr.	Bezeichnung	Menge
Pos.	Reference No.	Item	Pcs.
1	30.0104-002	Hranol / Prisma / Prism	1
2	30.0104-004	Držák pružiny / Federhalter / Spring holder	1
3	30.0303-005	Šroub / Schraube / Screw M16	1
4	30.0505-011	Podložka / Scheibe / Washer	1
5	30.0508-004	Čep napínání / Spannungsbolzen / Stretching pivot	1
6	30.0508-701	Napínací kolo / Umlenkrad / Stretching wheel	1
7	30.0702-023	Distanční kroužek / Distanzring / Distance ring	1
8	30.0704-025	Příložka / Lasche / Splice plate	1
9	31.0104-006	Hvězdice / Stern / Star	1
10	90.004.2D.008	Šroub / Schraube / Screw M8x16 DIN 915	1
11	90.005.55.017	Šroub / Schraube / Screw M8x30 DIN 933	1
12	90.005.55.023	Šroub / Schraube / Screw M10x20 DIN 933	1
13	90.100.55.005	Matice / Mutter / Nut M8 DIN 934	1
14	90.300.0Z.012	Válcový kolík / Zylinderstift / Cylindrical pin 8x50 DIN 6325	1
15	90.350.0Z.002	Talířová pružina / Tellerfeder / Belleville spring 35.5x18.3x2.0x2.8	11
16	95.001.018	Ložisko / Lager / Bearing 2RS 6205	2
17	95.750.001	Kroužek / Ring / Ring Cu 16x1	2
18	95.800.012	Pojistný kroužek / Sicherungsring / Retaining ring Ø25 DIN 471	1
19	95.801.009	Pojistný kroužek / Sicherungsring / Retaining ring Ø52 DIN 472	1

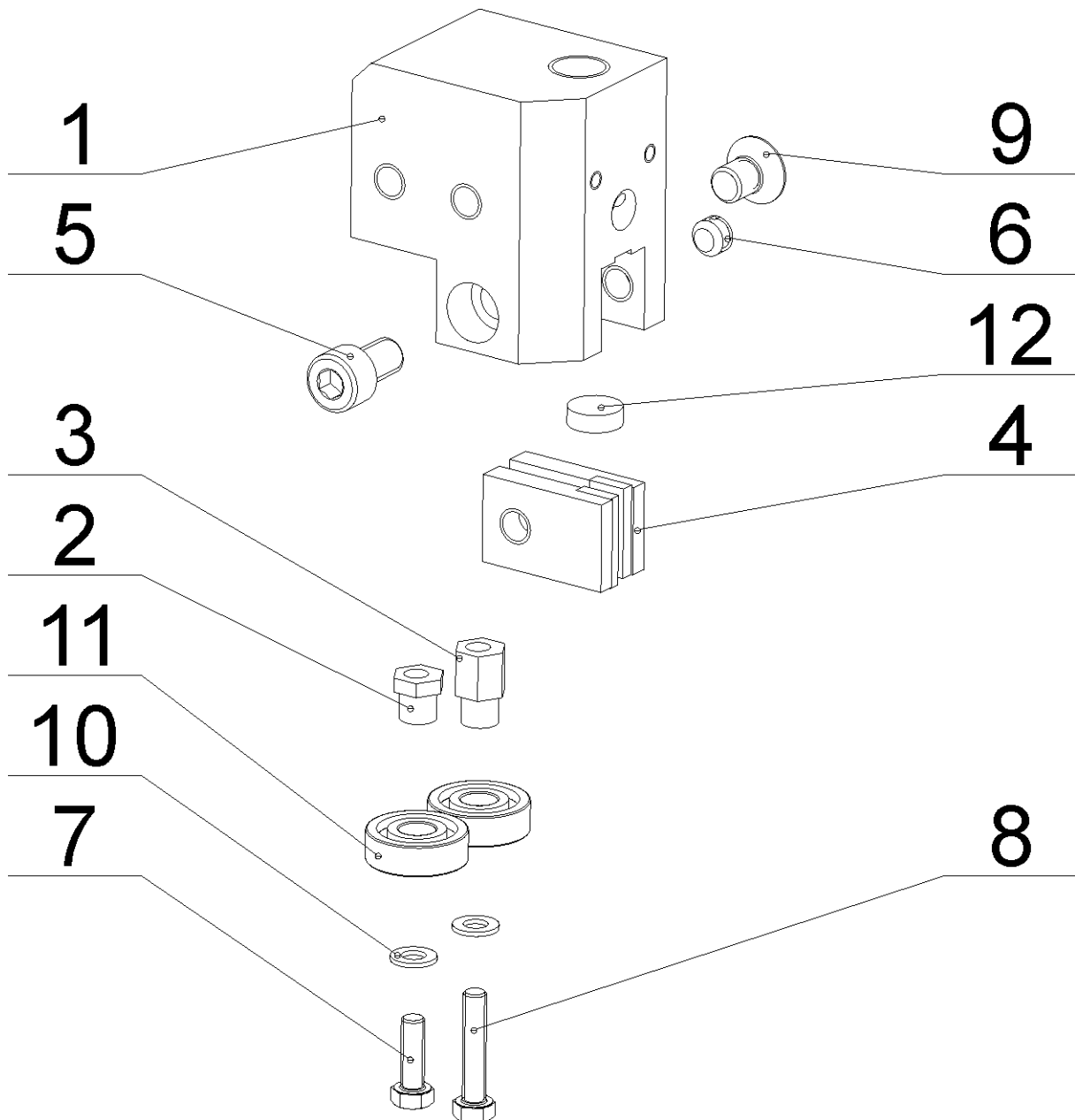

27.15. Levá vodící kostka / Linker Führungsklotz / Left guiding cube

Poz.	Objednací číslo	Název položky	ks
Pos.	Bestell - Nr.	Bezeichnung	Menge
Pos.	Reference No.	Item	Pcs.
1	30.0104-017	Levá vodící kostka / Linker Führungsklotz / Left guiding cube	1
2	30.0104-018	Excentr / Exzenter / Eccentric	1
3	30.0104-019	Excentr / Exzenter / Eccentric	1
4	30.0104-020	Držák tvrdokovu / HM-Halter / HM holder	2
5	90.001.25.030	Šroub / Schraube / Screw M8x14 DIN 912 8.8	1
6	90.002.2D.009	Šroub / Schraube / Screw M8x6 DIN 912 45H	1
7	90.005.55.003	Šroub / Schraube / Screw M5x16 DIN 933 8.8	1
8	90.005.55.005	Šroub / Schraube / Screw M5x25 DIN 933 8.8	1
9	90.011.27.007	Šroub / Schraube / Screw M8x12 DIN 7991 10.9	1
10	90.150.50.003	Podložka / Scheibe / Washer Ø5,3 DIN 125	2
11	95.001.001	Ložisko / Lager / Bearing 608 2RS	2
12	99.040.002	Tvrdokov / HM-Segment / Hardmetal Ø12x4	1

Poz.	Objednací číslo	Název položky	ks
Pos.	Bestell - Nr.	Bezeichnung	Menge
Pos.	Reference No.	Item	Pcs.
1	30.0104-018	Excentr / Exzenter / Eccentric	1
2	30.0104-019	Excentr / Exzenter / Eccentric	1
3	30.0104-020	Držák tvrdokovu / HM-Halter / HM holder	2
4	30.2804-002	Pravá vodící kostka / Rechter Führungsklotz / Right guiding cube	1
5	30.3510-002	Držák tvrdokovu / HM-Halter / HM holder	1
6	90.001.25.030	Šroub / Schraube / Screw M8x14 DIN 912 8.8	1
7	90.002.2D.009	Šroub / Schraube / Screw M8x6 DIN 912 45H	1
8	90.004.2D.017	Šroub / Schraube / Screw M5x8 DIN 915 45H	1
9	90.005.55.003	Šroub / Schraube / Screw M5x16 DIN 933 8.8	1
10	90.005.55.005	Šroub / Schraube / Screw M5x25 DIN 933 8.8	1
11	90.005.55.XXX	Šroub / Schraube / Screw M6x14 DIN 933 8.8	1
12	90.011.27.007	Šroub / Schraube / Screw M8x12 DIN 7991 10.9	1
13	90.100.55.004	Matice / Mutter / Nut M6 DIN 934 8.8	1
14	90.150.50.003	Podložka / Scheibe / Washer Ø5,3 DIN 125	2
15	95.001.001	Ložisko / Lager / Bearing 608 2RS	2
16	99.040.002	Tvrdokov / HM-Segment / Hardmetal Ø12x4	1

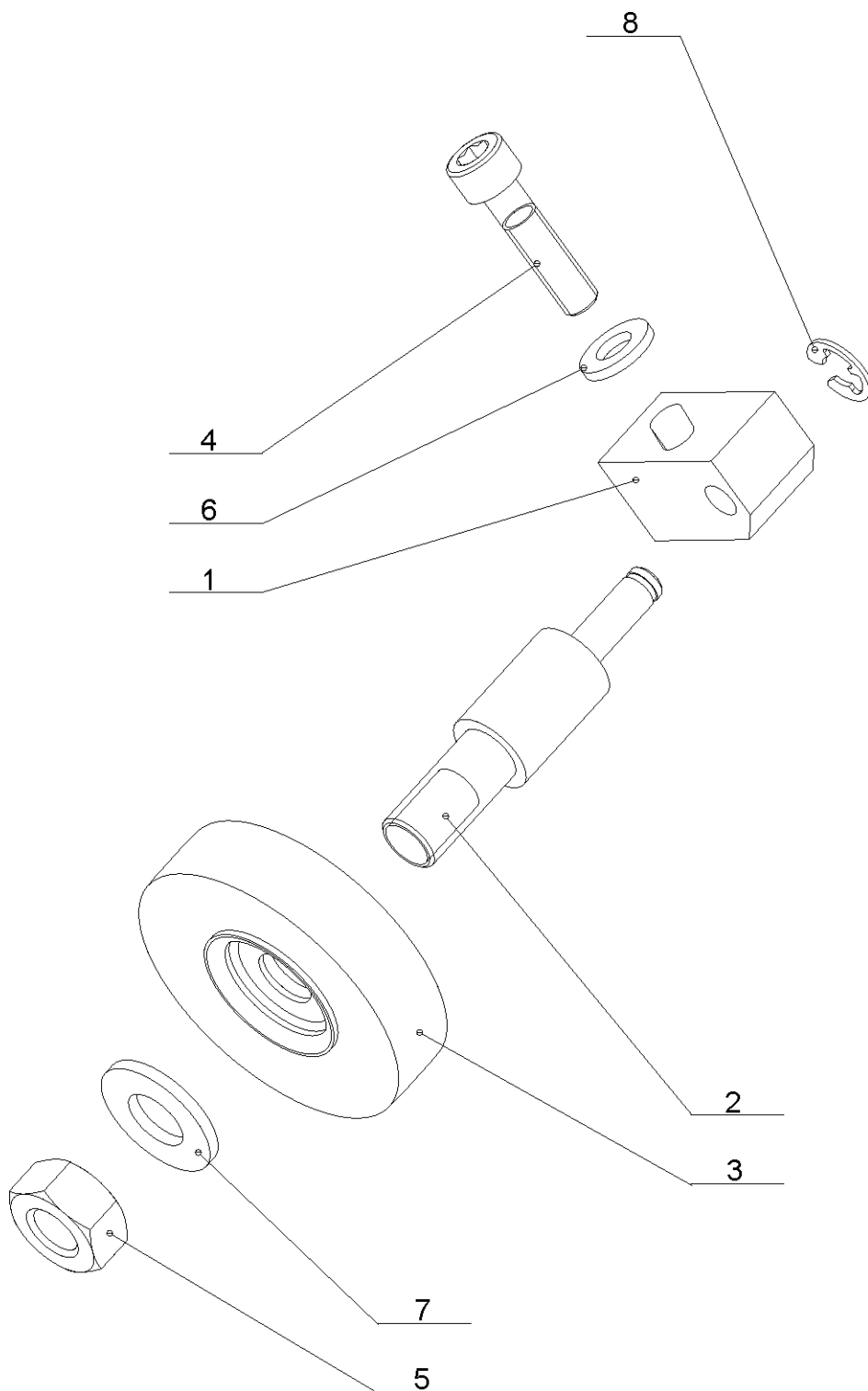

27.17. Kartáček / Spänbürste / Brush

Poz.	Objednací číslo	Název položky	ks	
Pos.	Bestell - Nr.	Bezeichnung	Menge	
Pos.	Reference No.	Item	Pcs.	
1	30.0104-022	Držák kartáčku / Bürstenhalterung / Brush holder	1	
2	30.0704-029	Hřídel kartáčku / Bürstenwelle / Brush shaft	1	
3	31.0704-031	Kartáček / Bürste / Brush	1	
4	90.001.25.019	Šroub / Schraube / Screw	M6x25 DIN 912	1
5	90.100.55.006	Maticice / Mutter / Nut	M10 DIN 934	1
6	90.150.50.004	Podložka / Scheibe / Washer	Ø6,4 DIN 125	1
7	90.150.50.006	Podložka / Scheibe / Washer	Ø10,5 DIN 125	1
8	95.800.001	Pojistný kroužek / Sicherungsring / Retaining ring	Ø6 DIN 471	1