

## IPG-85X20PSE-Q4GN

2.0M Black light illumination 4G dual-line network camera module

### Features:

- 2.0M resolution, Black light illumination clear and fine images;
- Support for wired and 4G connections
- Support 2D/3D noise reduction,digital wide dynamic;
- Advanced H.265X video compression,Super low rate,high definition quality of image;
- Professional anti-lightning,conform to GB/T17626.5 and IEC61000-4-5.
- Support mobile phone monitoring(iOS, Android);
- Support cloud technology,easy to achieve network penetration,fro in-line and alarm information pushed



### Parameters:

Model	IPG-85X20PSE-Q4GN
System structure	Embedded RTOS, dual-core 32-bit DSP (XM530),pure hard compression ,watch dog
Sensor	2.0M 1/2.9"SC307E Black light illumination CMOS sensor ,color 0.001Lux@F1.2,black/white 0.0001Lux@F1.2
Video compression	H.265X coding,support dual stream,AVI;0.1M~8Mbps variable
Image output	Main stream: 1920*1080@12fps; sub-stream: 640*360@12fps
Shutter	1/50(1/60)s to 1/10,000s
Lens	N/A
Day and night	Support IR-CUT
Noise reduction	Support 2D/3D
Wide dynamic	Support
Auto iris	N/A
Audio compression	G.711 standard compression,support two-way Bidirectional Talk,support for audio and video synchronization
Audio interface	1ch input,level:2Vp-p,impedance:1kΩ,support sound pick-up input;1ch output,impedance:16Ω,30mw,support microphone;
Network interface	1 RJ45 Ethernet interface, 10/100M adaptive
Extension interface	N/A
Singal interface	one IR-CUT interface
PTZ	N/A
Motor interface	N/A
Alarm I/O	N/A
Wireless interface	1 * binding China Telecom 4G card (default) + 1 * binding China Mobile 4G card (replaceable)
Reset interface	Support
Storage mode	Local TF card storage, up to 128G; cloud storage
Reliability	Comprehensive lightning protection, 7 * 24 hours 65 °C high temperature stable and reliable testing
Intelligence analysis	Supporting human detection and customizing other intelligent functions
Other function	Support cloud technology,easy to achieve network penetration,fro in-line and alarm information pushed
ONVIF	Support
Mobile monitoring	Support multiple mobile monitoring (iOS, Android)
Power	DC5V-12V
Dimension	38mm*42mm+38mm*40mm+38mm*38mm
Other	Does not accept any custom.

BLK530AI-40X38-4G-WP1 V1.01

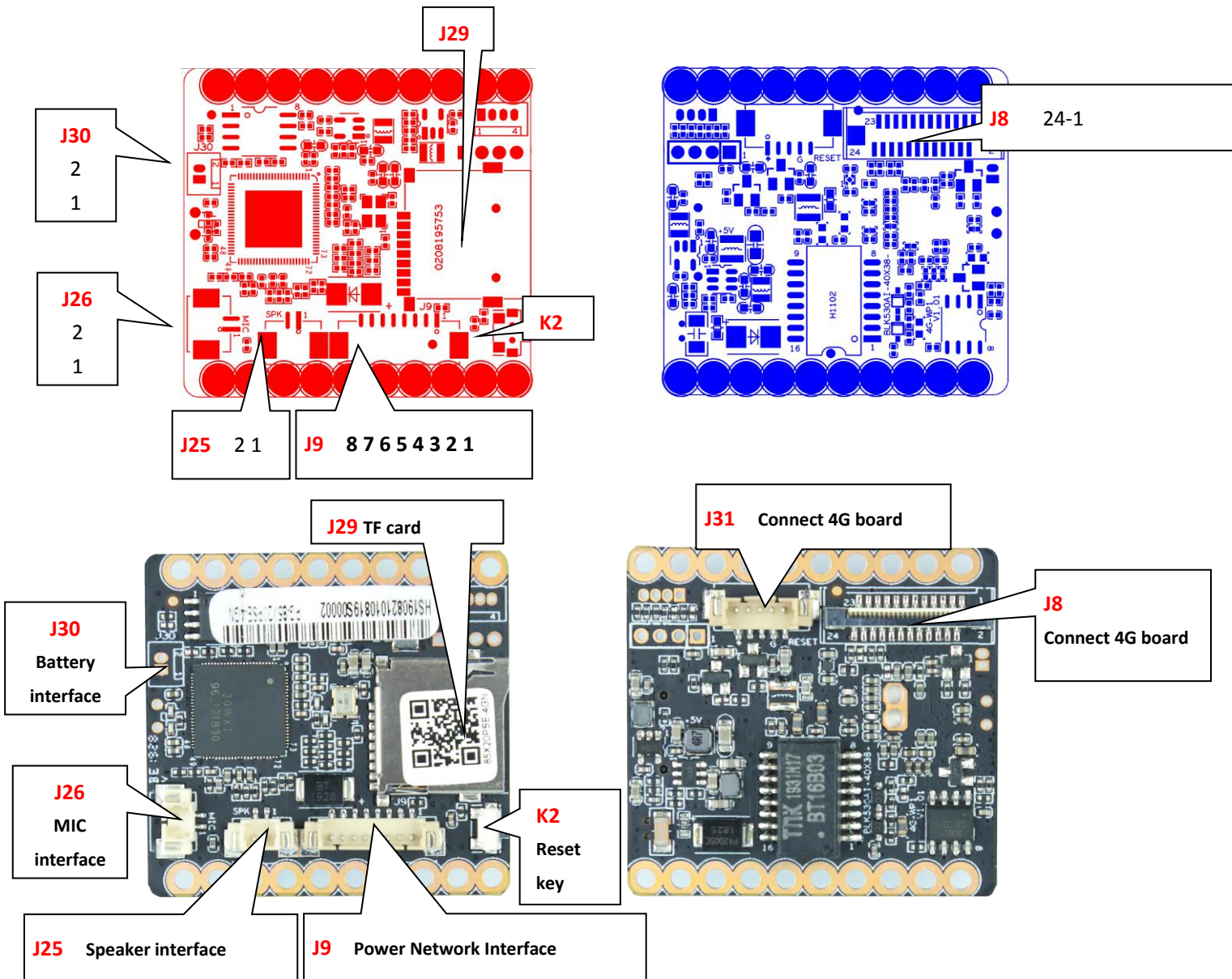

Socket	Specific No	Interface Description	Function
J26	1	MIC_G	Connect the MIC
	2	MIC_IN	
J25	1	SPKN	Connect the speakers
	2	SPKP	
J9	1	KEY_SET	Connect the tail line of the camera module
	2	LED1/PHY_AD1+	
	3	ETHTX+	
	4	ETHTX-	
	5	ETHRX+	
	6	ETHRX-	
	7	GND	

	8	12V	
J8	1	I_MIPI_DATA1N	Connect the sensor module
	2	I_MIPI_DATA1P	
	3	I_MIPI_DATA2N	
	4	I_MIPI_DATA2P	
	5	I_MIPI_DATA3N	
	6	I_MIPI_DATA3P	
	7	I_MIPI_CLKP	
	8	I_MIPI_CLKN	
	9	I_MIPI_DATA0P	
	10	I_MIPI_DATA0N	
	11	GND	
	12	ADC1_IN	
	13	SEN0_MCLK	
	14	GND	
	15	SDA	
	16	SCL	
	17	IRCUT_A	
	18	IRCUT_B	
	19	IR_CTRL/ALARM_IN	
	20	GND	
	21	LED_CTRL/ALARM_OUT	
	22	PWM	
	23	GND	
	24	+5V	
K2	KEY_SET		Reset key
J29	SD		TF
J31	1	+5V	Connect 4G board
	2	USB_DN	
	3	USB_DP	
	4	GND	
	5	4G_RESET	
J30	1	3V3	Battery interface
	2	GND	

## CMOS0235P-38X38-WP1 V1.02

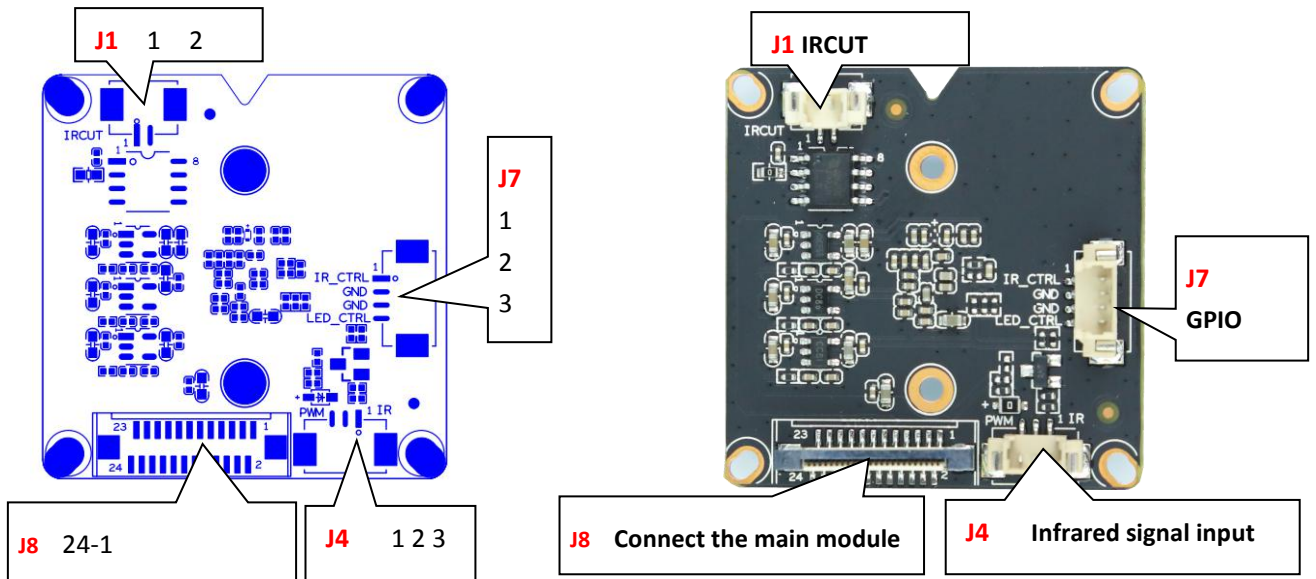

Socket	Specific No	Interface Description	Function
J4	1	RED_CTRL	Infrared signal input
	2	GND	
	3	PWM	
J7	1	IR_CTRL/ALARM_IN	GPIO
	2	GND	
	3		
	4	LED_CTRL/ALARM_OUTPUT	
J1	1	IRCUT_A	IRCUT
	2	IRCUT_B	
J8	1	I_MIPI_DATA1N	Connect the main module
	2	I_MIPI_DATA1P	
	3	NC	
	4	NC	
	5	NC	
	6	NC	
	7	I_MIPI_CLKP	
	8	I_MIPI_CLKN	
	9	I_MIPI_DATA0P	
	10	I_MIPI_DATA0N	
	11	GND	
	12	ADC1_IN	
	13	SEN0_MCLK	
	14	GND	
	15	SDA	

16	SCL
17	IRCU_T_A
18	IRCU_T_B
19	IR_CTRL/ALARM_IN
20	GND
21	LED_CTRL/ALARM_O UT
22	PWM
23	GND
24	+5V

**IF-4G-38X42 V1.02**

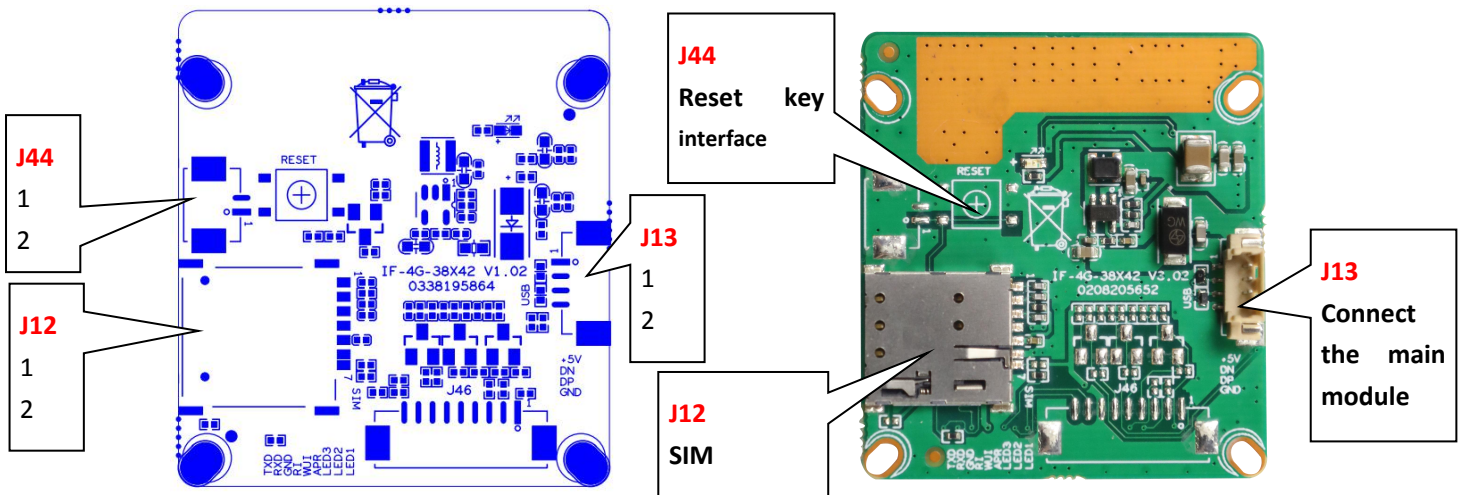

J44	1	KEY_SET	Reset key interface
	2	GND	
J13	1	+5V	Connect the main module
	2	USB_DN	
	4	GND	

